

TYPE B GAS VENT

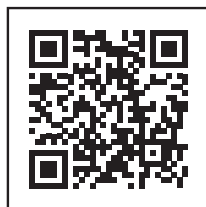

Round and Oval Type B GasVent Systems for use with natural gas or liquid propane category I and draft hood equipped appliances and appliances listed to use Type B Gas Vent.



duravent™

- Scan Code For French and Spanish Instructions
- Scannez le code pour les instructions en français et espagnol
- Código de escaneo para francés e instrucciones en español

A MAJOR CAUSE OF VENT RELATED FIRES IS FAILURE TO MAINTAIN REQUIRED CLEARANCES (AIR SPACES) TO COMBUSTIBLE MATERIALS. IT IS OF THE UTMOST IMPORTANCE THAT TYPE B GAS VENT BE INSTALLED ONLY IN ACCORDANCE WITH THESE INSTRUCTIONS.

IMPORTANT:

Read through all of these instructions before beginning your installation. Failure to install this product as described in these instructions will void the manufacturer's warranty, may create a fire or other safety hazard, and may affect your homeowner's insurance and safety listing of your appliance.

Keep these instructions for future reference.

Dear Customer, Installer, or End User:

We welcome any comments regarding matters pertaining to our DuraVent products. We welcome any ideas, input or complaints and somebody will respond directly back to you.

Send your emails to:

customerservice@duravent.com

If you are searching for tech support or product information, please call us at 800-835-4429.

Or email us at:

techsupport@duravent.com

Tested to Standards:

UL 441

&

CAN/ULC-605



LISTED

MH6357 AND MH14089

NOTE: DIAGRAMS & ILLUSTRATIONS ARE NOT TO SCALE.

TYPE B GAS VENT INSTALLATION INSTRUCTIONS

TYPE B GAS VENT

CONTENTS

| | |
|---|---------|
| Certification Labels | 4 |
| SECTION 1 (Small Diameter Model BV - 3" to 8") | 5 - 18 |
| Vent Designations/Types of Appliances and Buildings, Joint Method | 5 - 6 |
| Air Supply, Vent Clearances, Location and Enclosures | 6 - 7 |
| Vent Connector Type and Size, | 7 - 8 |
| Firestopping, Attic Insulation Shield, Wall Support / Wall Band | 8 - 9 |
| Gas Vent Fittings, Fixed Wye | 9 - 10 |
| Male and Female Universal Adapters, Gas Vent Height | 10 - 11 |
| Supports - Primary, Round Support Bucket | 12 - 13 |
| Quick-Grip, Offset, Flashings | 14 |
| Vent Terminations | 15 - 16 |
| Vent Operation, Painting | 16 |
| DuraConnect II | 16 - 20 |
| DuraConnect I | 20 - 21 |
| SECTION 2 (Large Diameter Model BV - 10" to 30") | 21 - 27 |
| Illustrations | 22 |
| Draft Hood Connectors, Firestop Support Plate, Joint Method | 22 - 25 |
| Adjustable Length, Gas Vent Fittings | 25 - 26 |
| Terminations, Offset Table, Flashings | 26 - 27 |
| Vent Operation, Painting | 28 |
| SECTION 3 (Model BVO Oval - 4", 5", 6") | 28 - 29 |
| 4, 5, 6-Inch Oval Installation in 2x4 Inch Stud Walls | 29 |
| 4-Inch Oval Installation as B-W Gas Vent | 30 |
| 4-Inch Oval Installation as B-W in Multi-Story | 30 - 31 |
| Attic Shield, Joint Method - Lock and Unlock | 31 |
| Warranty | 33 |

duraTMvent

CERTIFICATION LABELS

| | | |
|--|---|-------------------------------------|
| <p>duravent[™] VACAVILLE, CA 95688</p> <p>LISTED MH6357 TESTED/TESTÉ U/L441, CAN/ULC-615</p> | <p style="text-align: center;">UL us</p> <p style="text-align: center;">PRODUCT DESCRIPTION FRENCH PRODUCT DESCRIPTION</p> <p style="text-align: center;">FOR INTERIOR USE, EXTERIOR USE ABOVE ROOF LINE OR ENCLOSED EXTERIOR. POUR USAGE INTÉRIEUR, USAGE ÉTÉRIEUR DANS UNE ENCEINTE, OU USAGE ÉTÉRIEUR DANS UNE ENCEINTE.</p> | <p>ID</p> <p>UP HAUT</p> |
| <p>MINIMUM CLEARANCE TO COMBUSTIBLES, 1 INCH (25MM) IN US & DIAMETERS SMALLER THAN 24" IN CANADA. MINIMUM CLEARANCE 1 COMBUSTIBLES 2" (50MM) FOR DIAMETERS 24" AND LARGER IN CANADA. THIS VENT IS FOR USE WITH GAS APPLIANCES INSTALLED WITH DRAFT HOODS AND OTHER LISTED GAS APPLIANCES SPECIFIED FOR USE WITH TYPE B GAS VENTS (MAXIMUM TEMPERATURE OF FLUE PRODUCTS AT HOOD OUTLETS 470°F (245° C)). DO NOT CONNECT TO INCINERATORS OR SOLID OR LIQUID FUEL BURNING APPLIANCES. INSTALL ONLY IN ACCORDANCE WITH MANUFACTURER'S INSTALLATION INSTRUCTIONS.</p> <p>WARNING! FAILURE TO FOLLOW THE INSTALLATION INSTRUCTIONS COULD CAUSE FIRE, CARBON MONOXIDE POISONING, OR DEATH. IF YOU ARE UNSURE OF INSTALLATION REQUIREMENTS CALL THE PHONE NUMBER LISTED ON THE INSTRUCTIONS.</p> | | |
| <p>SMART #</p> <p>1 23456 78901 2</p> | <p>DÉGAGEMENT MINIMUM DES COMBUSTIBLES, 25MM (1 POUCE) AU ÉTATS-UNIS ET POUR DIAMÈTRES INFÉRIEURS À 24PO AU CANADA. DÉGAGEMENT MINIMAL AUX MATÉRIEAUX COMBUSTIBLES DE 2PO (50MM) POUR DES DIAMÈTRES DE 24PO ET PLUS AU CANADA. CET ÉVÈNT EST UTILISÉ SUR DES APPARELS AU GAZ, INSTALLÉS AVEC HOTTE DE TIRAGE ET TOUT AUTRE APPAREIL AU GAZ SPECIFIANT L'UTILISATION D'UN ÉVÈNT DE TYPE B (TEMPÉRATURE MAXIMUM DES GAZ D'ÉCHAPPEMENT À L'EMBOUCHURE DU DÉVIATEUR: 245° (470°F)). NE PAS RACCORDER À DES INCINÉRATEURS OU D'INSTALLATION DU FABRICANT. AVERTISSEMENT! NE PAS SUIVRE CES INSTRUCTIONS D'INSTALLATION PEUT FEU, EMPOISONNEMENT AU MONOXYDE DE CARBONE OU LA MORT. SI VOUS ÊTES INCERTAINS SUR LES PROCÉDURES D'INSTALLATION, VEUILLEZ COMMUNIQUER AU NO. DE TÉLÉPHONE INSCRIT SUR CES INSTRUCTIONS.</p> | |
| <p>PART # MADE IN/FABRIQUE AU XXXXXX DATE CODE OR WORK ORDER # PROD FAMILY</p> | | |

| | | |
|--|--|------------------|
| <p>duravent[™] VACAVILLE, CA 95688</p> <p>LISTED MH6357 TESTED/TESTÉ U/L441, CAN/ULC-615</p> | <p style="text-align: center;">UL us</p> <p style="text-align: center;">PRODUCT DESCRIPTION FRENCH PRODUCT DESCRIPTION</p> | <p>ID</p> |
| <p>TYPE B GAS VENT ÉVÈNT POUR GAZ DE TYPE B COMPONENT PART PIÈCE COMPOSANTE POUR</p> | | |
| <p>SMART #</p> <p>1 23456 78901 2</p> | <p>INSTALL AND USE IN ACCORDANCE WITH DURAVENT INSTALLATION INSTRUCTIONS. INSTALLER ET USE CONFORMÉMENT SEULEMENT SELON LES INSTRUCTIONS D'INSTALLATION DE DURAVENT.</p> | |
| <p>PART # MADE IN/FABRIQUE AU XXXXXX DATE CODE OR WORK ORDER # PROD FAMILY</p> | | |

SECTION 1

1. GAS VENT DESIGNATIONS/ TYPES OF APPLIANCES



DuraVent Model BV Type B Gas Vent parts LISTED and produced under the Factory Inspection and Follow-up program of Underwriters' Laboratories, Inc. and carry the LISTING MARK illustrated here. Type B Gas Vent has been tested, and listed using all of the supports, firestop, etc., described herein. Deletion or modification of any of the required parts or materials may seriously impair the safety of your installation, and void the certification and or warranty of this vent. It is of the utmost importance that this vent be installed only in accordance with these instructions. Model BV Round is listed to UL 441 and CAN/ULC-605 in diameters of 3" to 30". Model BVO Oval is listed to UL 441 in diameters of 4" to 6". Model BVO Oval is not available in Canada.

CAUTION: WEAR GLOVES WHILE HANDLING METAL PARTS TO AVOID PERSONAL INJURY. SHARP EDGES OR PROJECTIONS CAN CUT YOU.

WARNING

Failure to follow the installation instructions could cause **FIRE, CARBON MONOXIDE POISONING, OR DEATH**. If you are unsure of installation requirements, call the Phone Number listed on the instructions, 1-800-835-4429 or visit www.duravent.com.

2. TYPES OF APPLIANCES AND BUILDINGS

Model BV Type B Gas Vent is designed for venting listed Natural Gas or Liquid Propane Category I gas appliances equipped with draft hoods and other listed gas appliances specified for use with Type B gas vent producing flue gas temperatures not in excess of 470°F (245°C). These appliances include (but are not limited to) the following types: furnaces, boilers, water heaters, room heaters, unit heaters, duct furnaces, floor furnaces, and decorative appliances.

DO NOT USE Model BV Type B Gas Vent for wall furnaces "Listed" for use with Type BW Gas Vents only, incinerators and appliances Listed for use with chimneys only, combination gas-oil burning appliances, and appliances which may be converted readily to the use of solid or liquid fuels.

DO NOT USE Model BV Type B Gas Vent for Category II, III or IV gas appliances, or for any gas appliance which requires either a pressure-tight or liquid-tight venting system.

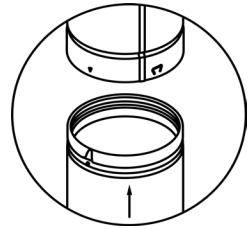

FIG. 1 - 3" to 8" BV

All sizes of Model BV Type B Gas Vent may be used in single and multistory buildings. All Model BV Type B Gas Vents may be used for both individual and multiple appliance venting.

Model BV Type B Gas Vents are to be installed and used in accordance with the "National Fuel Gas Code", NFPA 54, the "Standard for Chimneys, Fireplace and Venting Systems", NFPA 211, the "International Fuel Gas Code". In Canada, Model BV Type B Gas Vents are to be installed and used in accordance with the "Canadian Fuel Gas Installation Code", CSA-B149.1-00, and/or applicable local/regional codes. Model BV Type B Gas Vent is also suitable for use in existing, otherwise used and new masonry chimneys to protect the chimney from damaging effects of moist combustion products from the appliances listed above. NEVER USE Model BV Type B Gas Vent on any appliance that is not listed and approved for venting with Type B Gas Vent.

3. GAS VENT JOINT METHOD

All joints of Model BV Type B Gas Vent must be secured using the "DuraLock" feature. To use the DuraLock feature, orient sections as shown in Fig.1 and push adjacent pieces together until fully engaged. NOTE: Some local jurisdictions require a supplemental screw(s) at joints to prevent disengagement of the joint. Although not required under the terms of the UL Listing because of the integral couplers, screws are permitted to be installed at the joints in 3" through 8" vent. In such case, the screws should be located approximately 1/4" from overlapped edge and must be maximum 1/4" in length so they do not pierce or deform the inner liner.

The DuraTab® feature provides the equivalent of using a screw. Once engaged (with finger or

thumb until it bends into the groove in the top/ outlet end of the adjacent piece), it prevents the pipes from being disengaged unless the tab is pried back out and dimples aligned.

NOTE: FOR JOINT METHOD ON LARGE MODEL BV, SEE PAGE 24, SECTION 2 IN THESE INSTRUCTIONS.

5. VENT CLEARANCES, LOCATION AND ENCLOSURES

U.S.A.: DuraVent Model BV Type B Gas Vents 3 through 30 inch sizes must be installed with the required **MINIMUM AIR SPACE CLEARANCE TO COMBUSTIBLES** as stated below!

Canada: DuraVent Model BV Type B Gas Vents must be installed with the required **MINIMUM AIR SPACE CLEARANCE TO COMBUSTIBLES** as stated below!

Maintain the required minimum air space clearance to combustibles, wires, and insulation:

1" - for 3" thru 30" installed in the U.S.A.

1" - for 3" thru 24" installed in CANADA

2" - for 26" thru 30" installed in CANADA

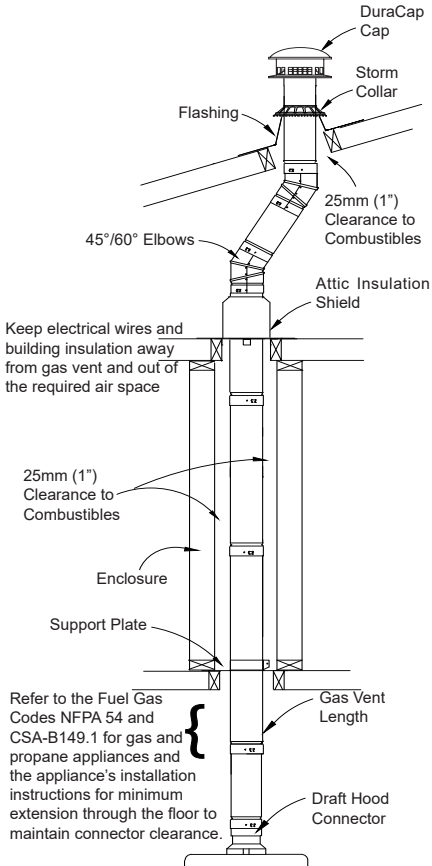

FIG. 2 - Typical Installation of Model BV (3" to 8")

4. AIR SUPPLY

Refer to the appliance installation instructions and consult local building codes and/or NFPA 54 "National Fuel Gas Code" or the Canadian Gas Installation Code CSA-B149.1.00 to ensure compliance with required volume of combustion air for each appliance installed.

These clearances are marked on all gas carrying items. They apply to indoor or outdoor vents whether they are horizontal or vertical, or pass through floors, walls, roofs or framed spaces. The appropriate clearance should be observed to joists, studs, subfloors, plywood, drywall, or plaster enclosures, insulating sheathing, rafters, roofing, and any other materials classed as combustible. **KEEP ELECTRICAL WIRES AND BUILDING INSULATION AWAY FROM GAS VENT AND OUT OF THE REQUIRED AIR SPACE!**

Single wall materials used as vent connectors are not permitted to be enclosed. There is no need to enclose Model BV Gas Vent where used as connectors under floors, in crawl spaces and basements, or in normally unoccupied or in inaccessible attics. Enclosing the vertical portions of vents is required where they pass through rooms, halls or other occupied spaces.

NOTE: See pages 21-27 (Section 2) of these instructions for additional information on the installation of Large Diameter Model BV Type B Gas Vents for diameters of 10" to 30".

DuraVent Type B Gas Vents are recommended to be installed within the heated portion of the structure wherever possible to reduce heat loss which may in turn lead to poor draft and/or condensation or/and ice problems.

If an exterior location is necessary, an exterior located Gas Vent (as per Figure 3) must be:

- Enclosed by a chase spaced out 1" from the vent at least to the roof line.
- The enclosure should be caulked to prevent entry of moisture.
- It is also recommended that this chase be insulated to a minimum of R-12 (RSI 2.1).
- Rigid type insulation is recommended. If a non rigid type is used, it must be restrained in such a manner so that the required minimum air space clearance to combustible is respected.
- The bottom of the enclosure must be closed off.
- It is recommended to provide an access panel for future inspection and cleaning of the vent.

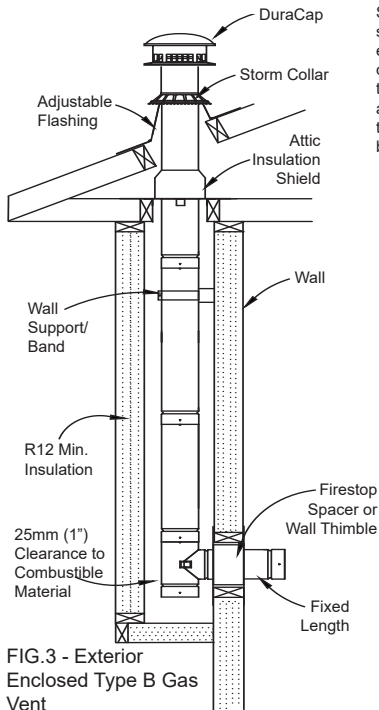

FIG.3 - Exterior Enclosed Type B Gas Vent

Appliances served by an exterior gas vent must have an air supply to the appliance room adequate to balance indoor and outdoor pressures. Otherwise, "stack action" of the heated building can cause reverse venting action when the appliance is off, or operating on its pilot.

In multi-family residential, high rise and many other types of buildings, codes specify that vents must be located in fire-rated shafts or chases. Building code requirements in such cases must be carefully followed with respect to wall construction, access, clearance, support, initial penetration of breaching, and method of termination.

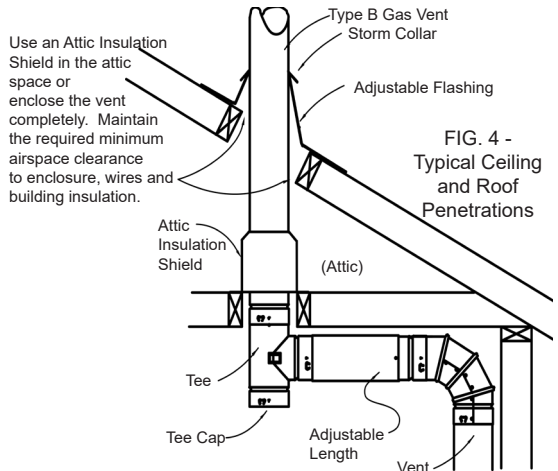

FIG. 4 - Typical Ceiling and Roof Penetrations

6. VENT CONNECTOR TYPE AND SIZE

Model BV Type B Gas Vent meets all building codes and safety standards for use as gas appliance vent connectors. Correct selection of connector and vent size is detailed in the "National Fuel Gas Code" (NFPA 54) and the Canadian Gas Installation Code CSA-B149.1-00, and/or local/regional codes.

Draft Hood Connectors must be attached to the appliance outlet with screws. Single wall connectors, if used must be secured to the appliance, to the gas vent, and at all joints with 3 sheet metal screws per joint. Attachment of vent to non-metallic outlets should be per appliance manufacturer recommendations. NOTE: See the Large Diameter Model BV in Section 2 for the requirement of Draft Hood Connectors.

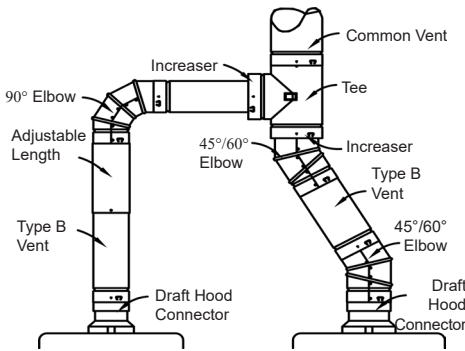

FIG. 5 - Combined vent system using type B Parts starting with Draft Hood Connectors.

7. FIRE STOPPING

All Type B Gas Vents passing through floors, ceilings or walls must be firestopped using the Firestop Spacer. The Firestop must close the area between the outer wall of the pipe and the opening in the structure. In areas such as attics with no floor, the Firestop should be placed on top of a properly framed opening. KEEP WIRES AND INSULATION OUT OF REQUIRED AIR SPACE AROUND GAS VENT. When venting is supported with the Support Plate it may serve as a Firestop. See Section 12. For gas vents within a shaft or chase, firestopping is provided by the vertical walls of the shaft. Any openings in the chase/shaft below the roof must be firestopped.

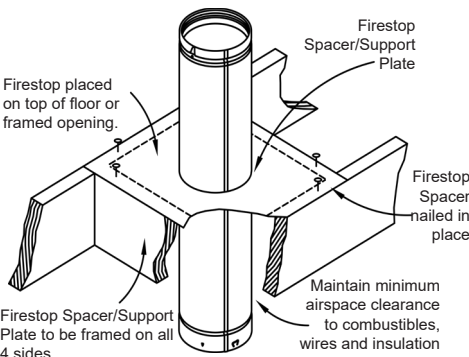

FIG. 6 - Fire Stopping Required for all Ceiling/Floor Levels

8. ATTIC INSULATION SHIELD

For diameters 3" to 8", install an Attic Insulation Shield where the vent passes into an attic space. It is designed to keep insulation materials or debris from coming into contact with the vent (see Figures 2, 3 & 4). It must accommodate the amount of insulation as required by the National Building Code. The Attic Insulation shield is adjustable from 11" to 20".

Where height restrictions will not permit the use of the Attic Insulation Shield, it is permissible to construct an enclosure with a 1" air space clearance to the outer pipe all the way to the underside of the roof deck. In this application you would install a Firestop Spacer on the ceiling side.

For a proper installation, the opening must be fully framed at 1" of clearance to the outer wall of the pipe with framing material of the same dimension as the ceiling or floor joist. Install the AIS from above and secure base with nails or wood screws.

Seal the vapour barrier to the firestop or ceiling support assembly using a high temperature silicone as per the requirement of local authorities.

NOTE: For larger diameters (10" to 30") a Firestop Support Plate must be used installed in a fully framed opening at the required air space clearances to combustible materials.

9. WALL SUPPORT/WALL BAND - FIGS 7 & 8

The Wall Support/Band is for use in supporting 35 ft. of vertical Model BV (3" to 8") and establishes the proper 1" clearance to wall to which it is attached, used at maximum 8 ft. spacing. May also be used to provide lateral support.

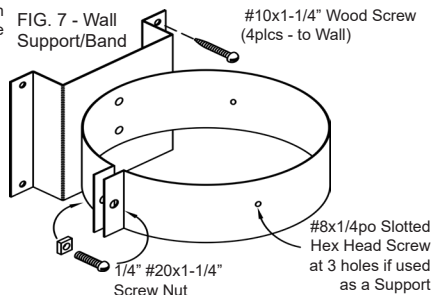

FIG. 7 - Wall Support/Band

When installed as a Wall Band, slip a vent section through the band and clamp loosely in place using the bolt and nut provided. Mark the locations for the screws which will attach the assembly to the wall. Secure the assembly using four #10 wood screws provided. Secure (clamp) the band around the vent by tightening the screw and nut.

When installed as a Wall Support, the band must be secured to the vent with the supplied 1/4" hex head screws. To do so, first install the assembly as indicated above for a Wall Band. With a 1/16" drill bit, carefully drill holes through the outside of the vent section (ONLY), using the holes in the band as a guide. Complete the assembly by inserting the #8x1/4" hex head screws through the holes (2 screws for 3" through 6", 3 screws for 7" and 8" diameter vent) and tighten.

NOTE: WHEN DRILLING OUTER WALL OF VENT BE CAREFUL TO DRILL THROUGH THE OUTER WALL ONLY, NOT THE INNER WALL.

NOTE: REMEMBER TO MAINTAIN THE REQUIRED MINIMUM AIR SPACE CLEARANCE TO COMBUSTIBLES FROM THE OUTSIDE OF THE VENT.

CAUTION: WEAR GLOVES WHILE HANDLING METAL PARTS TO AVOID PERSONAL INJURY, SHARP EDGES OR PROJECTIONS CAN CUT YOU.

10. USE OF GAS VENT FITTINGS

Do not cut gas vent pipe or fittings. Adjustable Lengths are telescoped over fixed lengths, to accommodate odd distances between vent lengths or connectors. An Adjustable Length suspended below a support serves as an expansion joint between two fixed points of properly supported gas vent. Ordinarily, the Adjustable Length must be secured, but for expansion joints it should just maintain good contact and a minimum 1-1/2" overlap. DO NOT USE Adjustable Lengths to suspend any weight of pipe below.

Elbows are fully adjustable. Tees used to start vertical vents must use a Tee Cap to prevent air leakage. All unused openings in a gas vent must be sealed to prevent loss of effective vent draft.

FIXED WYE - SIZES AVAILABLE

| BODY | BRANCH | CLEARANCE TO COMBUSTIBLES |
|------|--------|---------------------------|
| 4" | 3" | 1" |
| 4" | 4" | 1" |
| 5" | 3" | 1" |
| 5" | 4" | 1" |
| 6" | 3" | 1" |
| 6" | 4" | 1" |
| 6" | 5" | 1" |

On many newer gas appliances designed with efficiencies of 78% to 83% (mid-efficiency appliances, commonly referred to as fan assisted appliances), it is important that the connector system maintain the maximum amount of heat as possible, in order to reduce the chances of excessive condensation in the venting system

Therefore, according to the current vent sizing guidelines in many situations it will be necessary to use Type B vent as the connector system. As a convenience for use in such installations, a fixed wye fitting is available for maximum installation flexibility. The common vent extends from the ceiling and the wye is attached in the manner as a Tee. The body of the wye, can be rotated 360 degrees to accommodate the position of the water heater or smaller appliance.

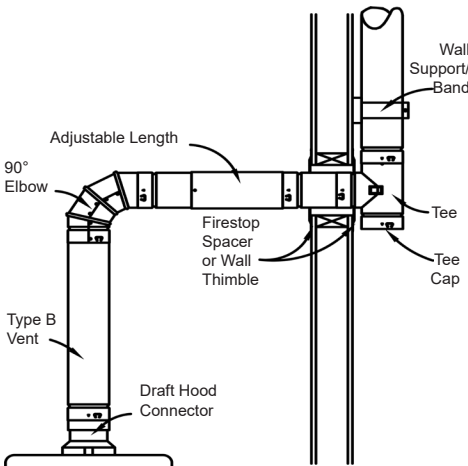

FIG. 8 - Interior Wall Penetration for Type B Vent

The lower section is connected to the main

appliance, or the larger of the two appliances. This section can be rotated 360 degrees with respect to the main body and branch of the wye is at a 60 degree angle. If two fan assisted appliances are used, Type B vent should be used on both connector systems. If only one fan assisted appliance is used, and sizing guidelines permit a single wall connector pipe may be attached to Model BV Fixed Wye fitting with a Draft Hood Connector and by inserting the crimped end of the single wall connector into the Draft Hood Connector and attaching with three sheet metal screws through the single wall pipe. Note: To avoid excessive condensation, single wall connectors should be used only in situations where sizing recommendations permits. When the wye fitting is attached to the appliance with Type B vent, the final connection can be made with either of two adjustable lengths to eliminate the need for special placement of either appliance. Adjustable lengths are available in 12" and 18".

VENT CONNECTOR TYPE AND SIZING

DuraVent Type B Gas Vent pipe meets all building code and safety standards for use as gas appliance vent connector and breechings. Correct selection of connector and vent size is detailed in the "National Fuel Gas Code", NFPA 54 in the US or the "Canadian Fuel Gas Installation Code", CSA-B149.1-00 in Canada for Connector and Vent Capacities and sizing recommendations.

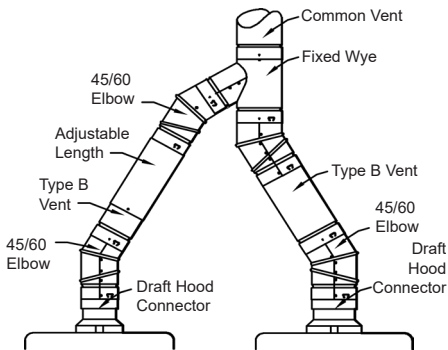

FIG. 9 - Fixed Wye

MALE AND FEMALE UNIVERSAL ADAPTERS

Male and female Universal Adapters are available in 3" through 8" ID sizes. Universal male adapters may be used to adapt to the top (outlet) end of a compatible round, Type B gas vent section, in order to continue the system toward the termination with Model BV joint coupling design.

Universal female adapters may be used to adapt to the bottom (inlet) end of a compatible Type B gas vent in order to continue the system toward the appliance using DuraVent round gas vent. The bottom end of the adapter incorporates the Model BV joint coupling design.

Compatibility

These fittings have been specifically evaluated and listed for use in adapting to other manufacturers of round Type B gas vents.

The following Type B gas vent products are directly compatible with DuraVent 3" through 8" Type B gas vent and require no adapters.

- Selkirk(current and former)
- Household Mfg. HVAC
- Eljer HVAC
- AirMate
- Hart & Cooley

MALE ADAPTER - INSTALLATION

The male adapter is a fitting designed to slide (telescope) down over the top end of the adjacent gas vent section with the inner, aluminum liner sliding inside the existing liner and the outer wall sliding outside (over) the outer wall (see Fig. 10A).

Longer (12" and 18") versions of the universal male adapter are offered as "Adjustable Lengths" for use either (1) in adapting to another manufacturer's gas vent or (2) in conjunction with another length section to develop an assembly of a specific dimension. TO INSTALL - Slide the adapter over the top (outlet) end of the adjacent gas vent being sure the aluminum inner wall slides within and the outer slides over the top. Push the adapter down until it overlaps at least 1-1/2".

Using the holes in the outer wall of the adapter as a guide, drill two holes through the outer wall (only) of the gas vent. Be careful not to penetrate the inner liner of the gas vent. Secure the adapter to the gas vent section with two 1/4" maximum length sheet metal screws (provided). The top (outlet) end of the system has now been converted to the DuraVent Model BV joint coupling design.

FEMALE ADAPTER - INSTALLATION

The female adapter is a fitting with a top end designed to slide over the outer wall of the bottom (inlet) end of the adjacent gas vent section (see Fig. 10B). TO INSTALL - Guide the top end of the adapter over the bottom (inlet) end of the adjacent gas vent being sure that the aluminum inner wall of the existing vent section slides inside the inner liner of the adapter and the outer wall of the adapter slides up and around the inlet end of the adjacent gas vent piece. Push the adapter up until it overlaps at least 1-1/2". Securely tighten the nut and bolt using a screwdriver and/or pliers. The bottom (inlet) end of the system has now been converted to the DuraVent Model BV joint coupling system.

UNIVERSAL ADAPTER - INSTALLATION

The female adapter is a fitting with a top end designed to slide over the outer wall of the bottom (inlet) end of the adjacent gas vent section (see Fig. 10B).

TO INSTALL - Guide the top end of the adapter over the bottom (inlet) end of the adjacent gas vent being sure that the aluminum inner wall of the existing vent section slides inside the inner liner of the adapter and the outer wall of the adapter slides up and around the inlet end of the adjacent gas vent piece. Push the adapter up until it overlaps at least 1-1/2". Securely tighten the nut and bolt using a screwdriver and/or pliers. The bottom (inlet) end of the system has now been converted to the DuraVent Model BV joint coupling system.

11. MINIMUM GAS VENT HEIGHT

A minimum gas vent height of 5 feet above the appliance draft hood is required (see Fig. 11).

Where the vent has an offset, or serves multiple appliances, greater heights may be required for proper venting.

Special care must be taken with short gas vents on duct furnaces, unit heaters, and furnaces in attics to ensure they have sufficient vent height. Refer to the appliance manufacturer instructions and local codes for required minimum heights.

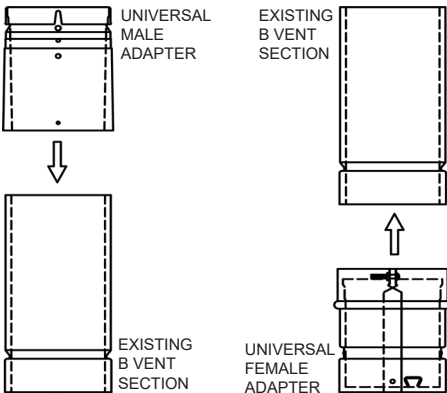

FIG. 10A

FIG. 10B

FIG. 10 - MALE AND FEMALE UNIVERSAL ADAPTERS

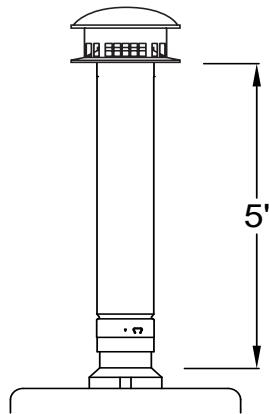

FIG. 11 - MINIMUM VERTICAL HEIGHT

12. SUPPORT - PRIMARY AND OFFSETS - 3" TO 8"

Gas vent piping must be securely supported. Lateral runs are to be supported at least every 5 feet. It is permissible to use the clamping band with a generic 26 gauge or heavier plate (if space requirements dictate).

FIRESTOP/SUPPORT PLATE

The Firestop/Support Plate has been tested to support a maximum of 35' of Gas Vent; if additional height is required, use another Support Plate on another floor level.

Cut away and frame a four sided opening in the floor from which the Gas Vent shall be supported, to provide 1" (25mm) minimum clearance to combustibles. See Fig. 12.

Nail Support Plate securely to joist and framing members using 4 x 1-1/2" long nails (1 nail at each corner).

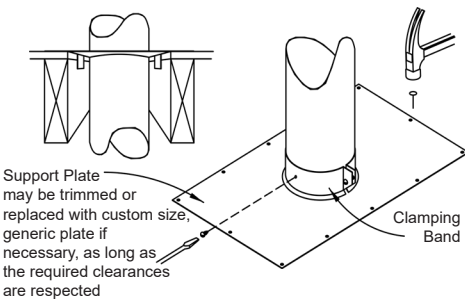

FIG. 12 - Firestop/Support Plate Assembly

Insert the first length from above through the clamping band and opening of the support plate to proper elevation. Secure clamping band to the length with tabs and 1/4" screws (provided) so weight of vent rests on plate. Room should be left for the draft hood connector and adjustable length.

Vertical runs fire stopped at 8 to 10 foot intervals need only be supported near the bottom. Additional Gas Vent Lengths above the Support are simply stacked on. See joining section to secure lengths together.

ROUND SUPPORT BUCKET (RSB)

The Round Support Bucket has been tested to support a maximum of 35' of Type B Gas Vent. Two supports are available: one to accommodate diameters of 3" and 4" and one for diameters of 5" and 6". A knockout is provided in each of the RSB for the larger diameters (4" and 6").

Each RSB comes complete with:

- 1 - Round Support Bucket
- 2 - Hanger Brackets
- 2 - Hanger Bars
- 2 - Pipe Supports (3" & 4" and 5" & 6")



Install the Hanger Bars through pairs of triangular openings in the side of the RSB. The open portion of the U-shaped Hanger Bar to be facing downward as shown below.



Nail both Hanger Brackets into the sides of joists.

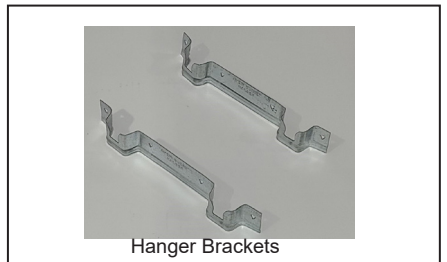

The bottom edge of the Hanger Bracket should be even with the bottom edge of joists. Use four (4) nails per bracket, nailing through small holes in the brackets (see below).

DO NOT RELY ON TRIANGULAR-SHAPED BARBS TO HOLD BRACKETS IN PLACE. BRACKETS MUST BE NAILED TO JOISTS.

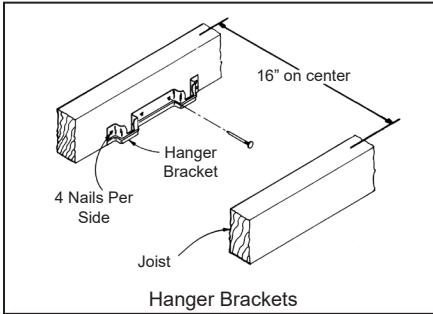

Snap the Hanger Bars previously assembled to the Round Support Bucket into the slots in the Hanger Bracket.

Slide the Pipe Support over the B Vent Length with the flanged edge to the bottom so it will make contact with the inside bottom of the Round Support Bucket. Slide the length through the round opening in the Round Support Bucket (if a 4" or 6" pipe is being installed, remove the knockout) where it will be joined to the adjacent pipe below.

Mark the proper elevation of the Pipe Support on the B Vent Length. Remove the length from the Round Support Bucket.

Using the elevation previously marked, locate and secure the Pipe Support with nut and bolt, drawing tabs together. Insert 1/4" screws (provided) through pre-punched holes in the Pipe Support and into the outer wall of the Length to prevent any slip.

Re-insert the assembly through the Round Support Bucket opening from above until the Pipe Support (now attached to the pipe) rests on the bottom of the Round Support Bucket. Connect to the lower pipes from the appliances (see below).

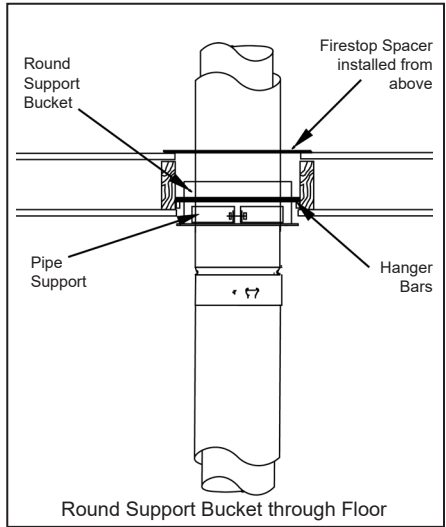
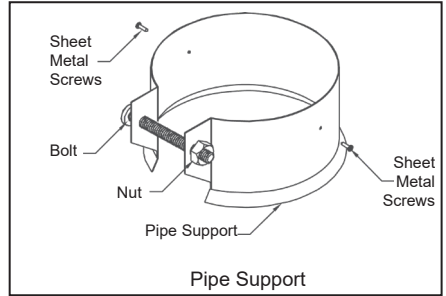

The Round Support Bucket does not serve as a firestop. A Firestop Spacer is required where the B Vent passes through a ceiling or floor joist. An Attic Insulation Shield is required if an attic space is immediately above the Round Support Bucket.

If an additional support is required, the Firestop/Support Plate or the Quick Grip Firestop/Support may be used on another floor level.

QUICK GRIP - FIRESTOP/SUPPORT

1. At the desired location, cut a square or circular hole in the floor at a minimum of 2-1/2 inches larger than the nominal pipe size, but not greater than 4 inches larger. See the table below. This will provide the REQUIRED 1-INCH CLEARANCE FROM COMBUSTIBLES.

2 Place the support over the hole with the gripping fingers up (see Fig. 13).

- Use an 8 penny nail or self-drilling sheet metal screw in each corner at least 3/8 of an inch in from the edge.
- Pipe should be inserted from below. A maximum of 30 feet of pipe may be installed above the support before resupport is required.

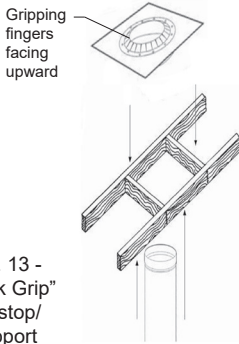

FIG. 13 -
"Quick Grip"
Firestop/
Support

| Nominal Pipe Size (inches) | Min. Hole Size (inches) | Max. Hole Size (inches) |
|----------------------------|-------------------------|-------------------------|
| 3 | 5.5 | 7 |
| 4 | 6.5 | 8 |
| 5 | 7.5 | 9 |
| 6 | 8.5 | 10 |

Tees used as vent inlets may be supported by sheet metal plates or brackets. Plumbers tape may be used to support both horizontal and vertical piping. Short vents with less than 6 feet of vertical pipe below the flashing may be suspended from the flashing. (The pipe may be supported by the storm collar resting on the top of the flashing). Use 1/4 inch long sheet metal screws to attach the storm collar to the pipe at the appropriate place. Apply silicone sealant over the sheet metal screw head. Gas vents supported only by the flashing must be guyed above the roof to withstand snow and wind loads. All gas vents extending above the roof more than 5 feet must be securely guyed or braced.

When offsets are necessary, adequate support above and below the offset is required. In addition, securing the offset elbow with three maximum 1/4" long sheet metal screws is recommended.

13. FLASHING

The roof opening should be located and sized such that the vent is vertical and has the required air space clearance. The Tall Cone Flashing is for flat roofs only (see Fig. 14). It is nailed in place through all four sides of the base flange. The Adjustable Roof Flashing (see Fig. 15) is positioned with the lower portion of the base flange over roofing material and the upper portion of the base flange under the roofing material. Nail through only the upper portion and sides of the base flange. (DO NOT nail through lower flange.) Use nails with a neoprene washer, or cover the nail heads with a silicone sealant. Finish roofing around the flashing, covering the sides and upper areas of the flange with roofing material. A non-hardening sealant may be used around the edges of the flashing base where it meets the roof.

FIG. 14
Tall Cone Flashing For
Flat Roofs Only

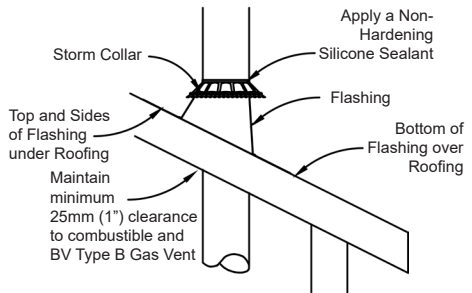
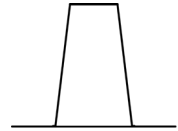

FIG. 15 - Flashing Installation

14. VENT TERMINATION

Gas vent piping must extend through the flashing to a height above the roof determined by Rule 1 or Rule 2 shown below. A storm collar is installed on the vent pipe over the opening between pipe and flashing. A non-hardening silicone sealant is used over the joint between pipe and storm collar. The top is securely attached to the gas vent as per section 15.

Rule 1: For Pipes 12" and Under

The top is suitable for installation on listed gas vents terminating a sufficient distance from the roof so that no discharge opening

is less than 2 feet horizontally from the roof surface, and the lowest discharge opening will be no closer than the minimum height specified in Fig. 16-B. These minimum heights may be used provided that the vent is not less than 8 feet from any vertical wall.

Rule 2 - Tops for gas vent sizes 14" and larger or less than 8' from vertical wall.
 For installations other than covered by the Table 1 (Fig. 16-B), or closer than 8 feet to any vertical wall, the DuraCap shall be not less than 2 feet above the highest point where the vent passes through the roof and at least 2 feet higher than any portion of a building within 10 feet. DuraCap 14" and larger must comply with Rule 2 regardless of roof pitch.

These rules were established on the basis of tests conducted in accordance with American National Standard ANSI/UL 441 and CAN/ULC-605.

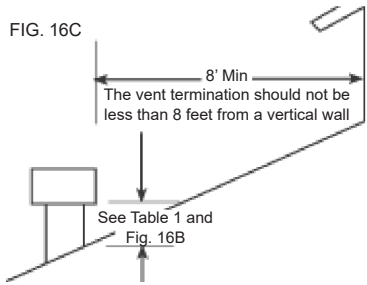
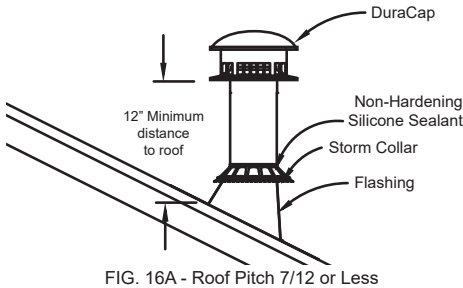

15. INSTALLATION OF MODEL BV CAPS

DuraCap and the Low Profile Highwind Cap are secured in place using a Locking Clip. The Locking Clip engages and snaps automatically in place under the inward curl when the caps are pushed into the upper end of the pipe. To remove pull up evenly on the opposite sides of the DuraCap or Low Profile Wind Cap (3" to 6"), see Figs. 17 A-B-C. The Standard High Wind Cap (3" - 8") uses the "DuraLock" feature. To use the DuraLock feature, orient sections as shown in Fig.1 and force the Standard High Wind Cap onto the upper end of the pipe until joint is fully/properly engaged. Engage the DuraTab® (with finger or thumb until it bends into the groove in the top/ outlet end of the pipe), preventing the pipes from being disengaged. To remove the top from the pipe, pry back out (with the end of a screwdriver), align the dimples and pull up evenly on opposite sides of the Standard High Wind Cap, see Fig. 17 D.

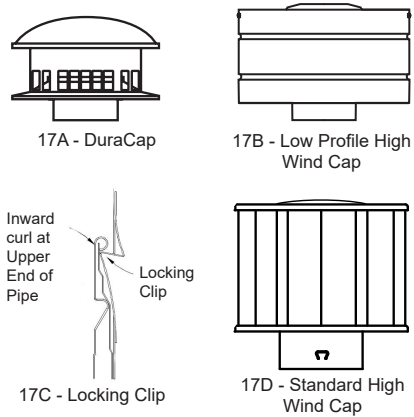
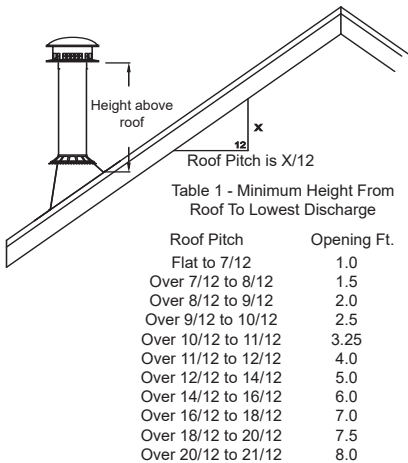

FIG. 16B - Location Rules for Flat to 21/12 Pitch

Figs. 17A-B-C-D - DuraCap and High Wind Caps

16. CHECKING VENT OPERATION

Complete all gas piping, electrical, and vent connections. After adjusting the appliance and lighting the main burner, allow a couple of minutes for warm-up. Hold a lighted match just under the rim of the draft hood relief opening (see Fig. 18). Proper venting will draw the flame toward or into the draft hood. Improper venting, indicated by escape or spillage of burned gas, will cause match to flicker or go out.

For fan assisted appliances, which have no draft hood, no such check is available. However, fan assisted appliances are designed to shut down if excessive pressure is detected at the outlet. If this occurs it may be an indication that the system is not venting properly.

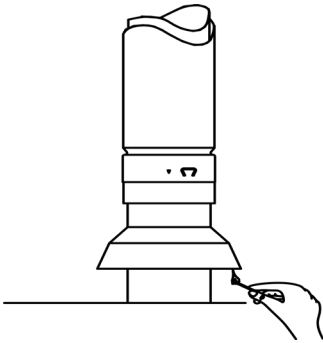

FIG. 18 - Match Test for Spillage

17. PAINTING

Exterior above the roof line portions of the vent may be painted with high temperature paint to prolong the life and appearance of the venting (and other components) of DuraVent Type B Gas Vents. Use proper painting procedure at time of installation.

Remove oil and dirt with a solvent and follow the paint manufacturer instructions. Ordinary house paints applied directly to steel may not adhere well and do not prevent underfilm corrosion which leads to paint loosening and peeling.

NOTE: IN CANADA, ANY PIPE ABOVE THE ROOF LINE MUST BE OF GALVALUME CONSTRUCTION, OR PAINTED.

These instructions should be observed when installing DuraVent Type B Gas Vents. For proper Sizing of the vent refer to the Sizing Tables found in the "National Fuel Gas Code", NFPA 54 in the US or the "Canadian Fuel Gas Installation Code", CSA-B149.1-00 in Canada.

DURACONNECT II

DuraConnect II Flexible Gas Vent Connector/Segment is an air-insulated double wall flexible venting product with comparable insulating value to Type B Gas Vent. DuraConnect II is Listed for two applications.

1. VENT CONNECTOR: May be used as a connector for Listed gas fired appliances equipped with draft hoods and other appliances listed for use with Type B Gas Vent. DuraConnect II may be used where Type B Gas Vent Connectors are required. (See Part 1).

2. VENT SEGMENT: DuraConnect II may be used (unenclosed) as a segment of standard Type B Gas Vent system in attics or crawl spaces. (See Part 2).

DuraConnect II may be sized in accordance with tables applicable to systems with Type B gas vent connectors, However, DO NOT ENCLOSE DuraConnect II.

CAUTION - RISK OF FIRE - DO NOT ENCLOSE. INTENDED FOR USE AS A VENT CONNECTOR OR FLEXIBLE SEGMENT OF VENT SYSTEM FOR UNENCLOSED PORTIONS OF INSTALLATIONS ONLY. Do not fully enclose or pass through combustible areas such as walls, ceilings or floors. Maintain specified minimum airspace clearance-to-combustibles.

General:

1) DuraConnect II Flexible Connector system is designed to simplify connection between gas burning appliances and Model BV Type B

Gas Vent systems by eliminating elbows and height interference sometimes associated with fixed lengths of rigid single wall or Type B Gas Vent. Individual lengths are provided with the same type of joint connector system as Model BV Type B Gas Vent, permitting simple attachment. Adaptation to other Type B Gas Vent may be accomplished by utilizing either Model BV Universal Female or Male B-Vent Adapters.

2) To size the connector system, follow approved engineering design practices such as the National Fuel Gas Code (NFPA 54) and Canadian Fuel Gas Installation Code (CSA-B149.1.00). Also check local code requirements.

3) In using DuraConnect II, overall considerations should be given to the following:

- a) Make short straight runs where possible.
- b) Make no unnecessary bends.
- c) Make no bends greater than 90 degrees.
- d) Make bends as smooth as possible with no dips or sags.
- e) Install with at least a 1/4" per foot (20mm/m) rise.

4) DuraConnect II Flexible Connector is Listed by Underwriters Laboratories (UL) for 1" (25mm) airspace clearance-to-combustibles in an unenclosed installation. THIS PRODUCT SHOULD NOT BE FULLY ENCLOSED OR PASS THROUGH A COMBUSTIBLE AREA SUCH AS A CEILING, WALL OR ROOF JOIST.

5) Use DuraConnect II (combination) Wall/Ceiling Support Spacers as necessary to assure correct clearances are maintained (see Fig. 19).

6) Never cut or modify the DuraConnect II length. Where possible, choose lengths which provide for proper overall length. If necessary, however, DuraConnect II lengths may be slightly compressed to obtain proper length (see Fig. 20). Extra care must be observed when bending the DuraConnect II in the compressed state. Use only Model DuraConnect II connector parts. Do not substitute other flexible pipe material.

7) Joint connection design eliminates the need for screws at joints between flexible sections and/or B-Vent sections. However short (maximum 1/4" (6mm)) sheet metal screws may be used if desired. Screws should not pierce or deform the B-Vent but may pierce the connector.

Use sheet metal screws as necessary to securely fasten flexible length or draft hood connector to the appliance outlet.

PART 1

DuraConnect II as a Vent Connector - Single Appliance System

1) Determine the approximate length and the path of the connector required to attach to the B-Vent system and the appliance being vented.

2) Select a length or lengths of flexible connector sufficient to extend from the Type B Gas Vent (which should be protruding into the appliance room) to the appliance to be connected. If the inlet of the existing Type B Gas Vent system is not compatible with the male end of the flexible connector, use a Model BV Universal Female B-Vent Adapter or a Universal Female Flexible Connector which are UL Listed and designed to adapt to most manufacturer's Type B Gas Vent (See Section 3). Insert the outlet (male) end of the Flexible Adapter into the inlet of the gas vent until it fully engages. Use #8x1/4" sheet metal screws to secure in place. (See Figure 19).

3) If local codes specify use of a "drip tee", a fixed adjustable wye or a tee may be included to make the connection to the B-Vent. DuraConnect II may also be used to connect to the round inlet of Model BVO oval B-Vent tee if desired (See Figures 22 and 23).

4) Once securely attached to the B-Vent, gently bend the flexible connector in the direction of the appliance to which it will be attached. (Be careful not to make any abrupt or sharp bends or create any bends greater than 90 degrees).

5) Attach the inlet (female) end of the flexible connector directly to the appliance draft hood or flue collar (if conditions and local codes permit). If necessary, a draft hood connector may be used between the draft hood/flue collar and the connector inlet.

6) If the flexible connector is too long, do not cut to length. Instead, compress it to an appropriate length as noted in Figure 20.

7) After making final connections, check the system for soundness of joint attachment and proper 1" (25mm) airspace clearance-to-combustibles. Install Wall Support Straps as necessary to eliminate sags and/or assure proper clearances.

DuraConnect II as a Vent Connector - Multiple Appliance System

- 1.) To common vent (connect to more than one appliance), select and install a fixed wye or tee at the base (inlet) of the Type B Gas Vent system, along with appropriate increasers (if necessary) at the inlets. (See Figure 24).
- 2.) Remember to reference the National Fuel Gas Code (NFPA 54) and Canadian Gas Fuel Installation Code (CSA-B149.1.00) and/or local code requirements to obtain the correct sizes for the connectors and common vent.
- 3.) After selecting and installing the appropriate tee or wye assembly at the inlet of the gas vent, connection of the individual appliances is accomplished in the same manner as described above for a single appliance connector system.

AFTER COMPLETING INSTALLATION OF CONNECTOR AND VENT SYSTEM, CHECK FOR PROPER VENT OPERATION. REFER TO GAS VENT INSTALLATION INSTRUCTIONS AND/OR Z223.1/NFPA 54 AND/OR CSA-B149.1.00 FOR GUIDELINES ON HOW TO CHECK FOR PROPER OPERATION.

PART 2

DuraConnect II as an Unenclosed Segment of a Type B Gas Vent System in Attics or Crawl Spaces - UNITED STATES ONLY!

DuraConnect II may be used as a segment of a standard Type B Gas Vent installation in attics or crawl spaces (only) provided the installation complies with the following criteria.

- 1.) DuraConnect II must never pass through or penetrate a wall, ceiling, floor or roof joist. (Such is to be done only with rigid lengths of B-Vent).
- 2.) DuraConnect II must never be fully enclosed.
- 3.) If installed in an attic, the B-Vent portion, penetrating the attic floor (to which DuraConnect II will be attached) must extend a minimum of three inches above the attic floor. Note: In Canada, DuraConnect II cannot be installed in an attic or crawl space.
- 4.) If installed in an attic, the B-Vent portion attached above DuraConnect II must be supported and stabilized using the method detailed in Figure 25 or by other generic methods as shown in Figures 25a - 25e.

- 5.) If installed in a crawl space, rigid B-Vent must extend through all penetration locations (wall, ceiling, floor) by at least 3 inches and must be supported/stabilized by using a Support Assembly or by other generic methods as shown in Figure 25 or figures 25a through 25e. NOTE: Not permitted in Canada.

*If local code requires an attic insulation shield to be installed above the attic floor, the DuraConnect II B-Vent Segment must extend above the Attic Insulation Shield.

TO INSTALL:

Select the length of Flexible Connector sufficient to extend from Model BV Type B Gas Vent to the appliance to be connected. Insert the outlet (male) end into the inlet end of the gas vent until it fully engages. Once securely attached to Model BV, gently bend the Flexible Connector in the direction of the appliance to which it will be attached. Be careful not to make any abrupt or sharp bends or create any bends greater than 90 degrees. Attach the inlet (female) end of the Flexible Connector directly to the appliance draft hood or the appliance flue collar. It is available in 3", 4" and 5" diameters and in 2', 3', 4' and 5' lengths.

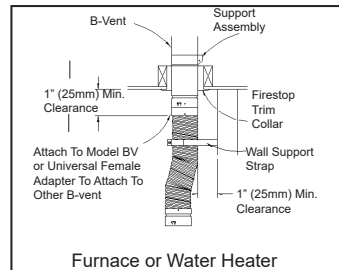

Fig. 19

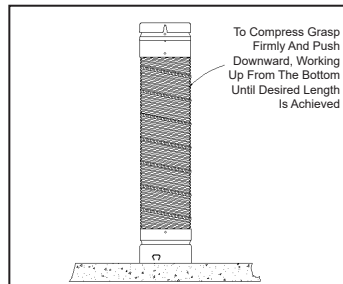
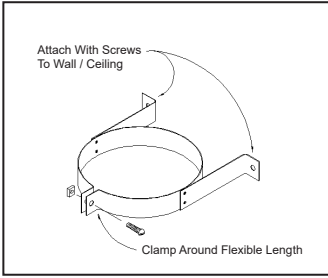

Fig. 20



DuraConnect II Wall Support Strap
Fig. 21

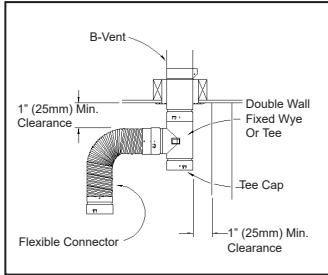

Fig. 22

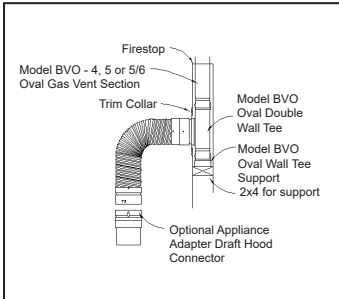

Fig. 23

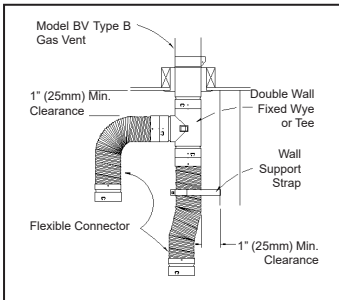

Fig. 24

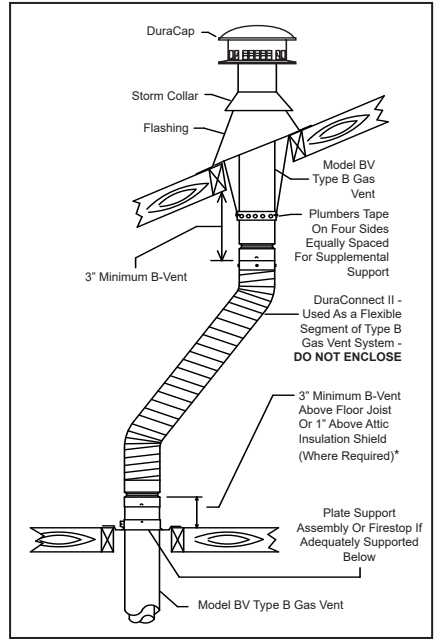

Fig. 25

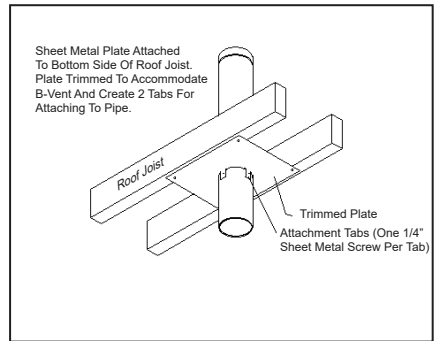

Fig. 25a

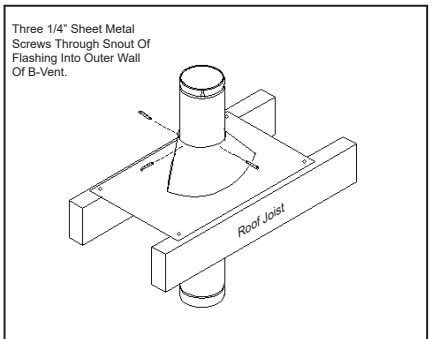

Fig. 25b

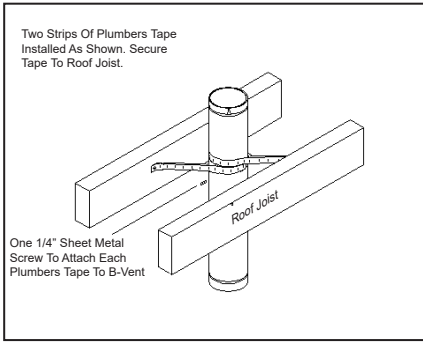

Fig. 25c

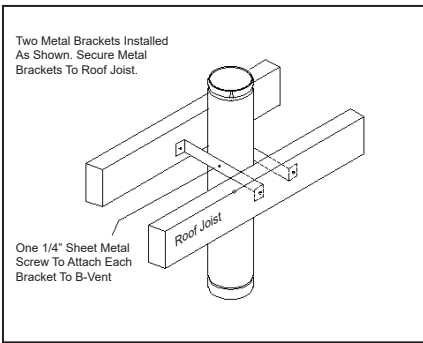

Fig. 25d

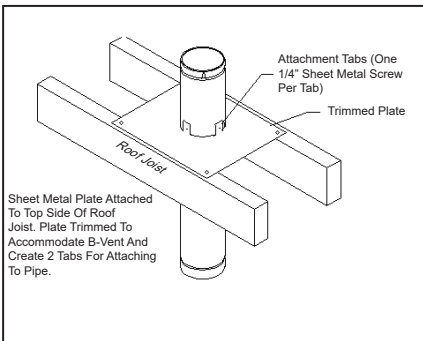

Fig. 25e

NOTE: In Canada DuraConnect II is NOT Permitted in an attic space (Figures 25, 25a to 25e).

20

DURACONNECT I

DuraConnect I is a Single Wall Expandable Flex Gas Vent Connector, designed for use as a connector for Listed gas fired appliances equipped with draft hoods and other appliances Listed for use with Type B Gas Vent.

DuraConnect I is designed to simplify a connection between a gas burning appliance and Type B Gas Vent systems by eliminating the need for a separate draft hood connector, straight pipe and elbows, removing the guess work of height interference sometimes associated with fixed lengths of rigid single wall or Type B Gas Vent.

Individual lengths are provided with the same type of outlet end connector as DuraVent Model BV Type B Vent, permitting simple attachment. The DuraConnect I Single Wall Expandable Flex Connectors are available in 3" and 4" diameters and can extend from 24" to 42" (3EFC) and from 30" to 60" (5EFC) in length, allowing a greater range of installations (see Figure 26).

DuraConnect I Expandable Flex Connector is Listed by Underwriters Laboratories (UL) for 1" (25mm) airspace clearance to combustibles in an unenclosed installation. At no time should this product be fully enclosed or pass through a combustible area such as a ceiling, attic, wall, roof joist, or crawl space.

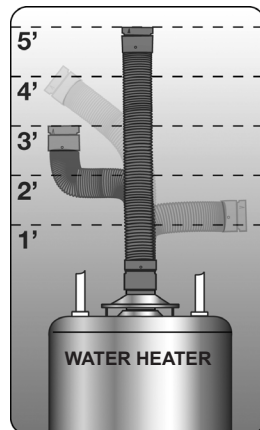

Fig. 26 - DuraConnect I is flexible and expandable to a maximum of 60" length, permitting a variety of orientations

NOTE: DIAGRAMS & ILLUSTRATIONS ARE NOT TO SCALE.

In using DuraConnect I, overall considerations should be given to the following:

- a) Make short straight runs where possible;
- b) Make no unnecessary bends;
- c) Make no bends greater than 90 degrees;
- d) Make bends as smooth as possible with no dips or sags;
- e) Install with at least a 1/4" per foot (20mm/m) rise.

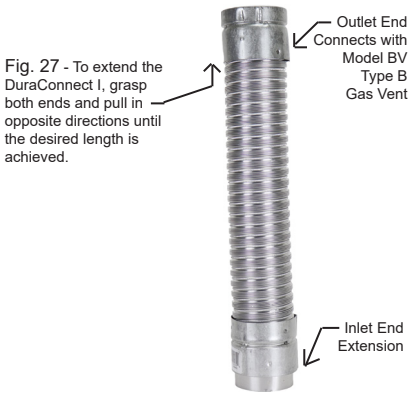

Fig. 27 - To extend the DuraConnect I, grasp both ends and pull in opposite directions until the desired length is achieved.

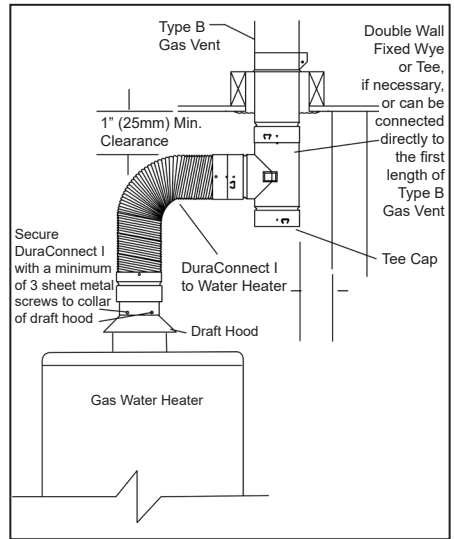

Fig. 28

If local codes specify use of a "drip tee", you may incorporate a fixed or fixed wye or a tee to make the connection to the Type B Gas Vent (see Figure 28).

To install: Extend inlet end down over collar of appliance draft hood and secure in place with minimum 3 screws (not supplied) through the inlet end extension of the DuraConnect I and the collar of draft hood (see Figure 28). With the DuraConnect I Inlet End secured to the draft hood, extend to the required length and secure the Outlet End of DuraConnect I to the inlet end of the Type B Gas Vent.

Never cut or modify DuraConnect I length. If necessary, the connector length may be slightly compressed to obtain proper length (see Figure 27). Extra care must be observed when bending the flexible connector in the compressed state.

The DuraConnect I is packaged in a slightly compressed mode. To extend to the required length stretch the DuraConnect I to the desired length by grasping the ends and pulling in opposite directions. This may be an easier task for 2 people or by attaching the inlet end to the water heater's draft hood first.

SECTION 2

MODEL BV LARGE DIAMETERS - 10" - 30"

NOTE: The following pages are additional information for the installation of the Large Diameter Type B Gas Vent Model BV. Reference all requirements found throughout these instructions.

See Figs. 29 to 31 of graphics illustrating the use of components required in the typical installations of Model BV (10" to 30") .

Type B Gas Vent Connectors

Attach the vent section directly to the draft hood of the appliance with three (3) sheet metal screws. Maintain the UL minimum airspace clearance to combustibles. Where the vent penetrates structure, use a Firestop and the Support Assembly to maintain proper clearance at this and successive intervals throughout the structure.

Basic Vent Structure

Large Diameter Model BV is available in sizes 10" to 30" and has a 1/2" space between pipe walls. When calculating the assembled length, allow 1" length reduction for the overlap at each joint.

Maintain minimum airspace clearance to combustibles, wires, and insulation:

- 1" - for 3" thru 30" installed in the U.S.A.
- 1" - for 3" thru 24" installed in CANADA
- 2" - for 26" thru 30" installed in CANADA

Draft Hood Connectors

Draft Hood Connectors must be attached to the appliance outlet with screws. Draft Hood Connectors are available in 10" to 18" diameters.

The accepted practice for larger diameters (20" to 30") is to attach a starting Length of 12" directly to the appliance flue outlet. Secure the Length to the appliance flue outlet with a minimum of three #8 x 1" sheet metal screws equally spaced using the existing outer wall lock slots as insertion point (see Fig. 32).

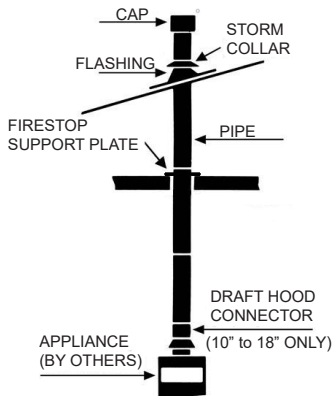

Fig. 29 - Type B Gas Vent - Single Appliance

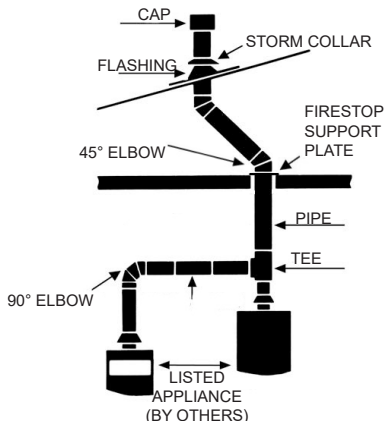

Fig. 30 - Type B Gas Vent - Multiple Appliances

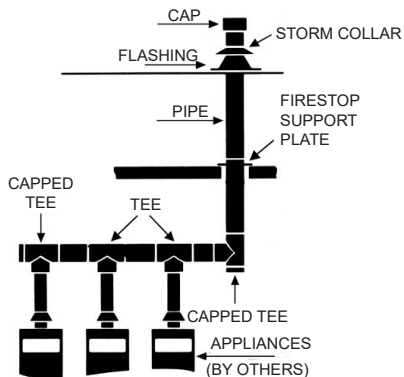

Fig. 31 - Type B Gas Vent - Multiple Appliances with Manifold



Fig. 32



Fig. 33

Universal Male Adapter - 10" & 12"

A Universal Male Adapter is available only in diameters of 10" and 12". It is used when adapting Model GV to Model BV. Position the Adapter over the male end of a Model GV length until fully seated. Secure in place with the 3 supplied sheet metal screws through the pilot holes.

Secure the screws until the head of the screws are flush with the outer casing (see Fig. 33). Penetrating through the inner wall is acceptable only at this point to secure to the appliance flue outlet.

SUPPORT OF VENT STRUCTURE

The Firestop Support Plate (FSP) is designed to be used with Type B Gas Vents in diameters of 10" to 30". The Vent Pipe Hanger (SBA) is designed for use with 10" and 12" diameters only. They are used to provide lateral and some vertical support for sections of vent, as well as the correct clearance to combustible materials. They also provide support and resupport for offsets and horizontal runs. In addition, field fabricated supports may be used. Consult local building codes for rules regarding field fabricated supports.

Firestop Support Plate (FSP)

Each Firestop Support Plate is designed to support up to 30 feet of Vent Pipe when installed as follows.

1. It is recommended that the vent pipe be supported at least every other floor. The distance between supports must not, in any case, exceed 30 feet.
2. The circular cutout in the Firestop Support Plate is designed to engage the uppermost recess in the female end of the vent pipe (see Fig. 34).
3. Surround the vent pipe with the two identical Firestop Support Plate halves (see Fig. 35). Engage the plate edges in the uppermost recess as described in Step 2. Use two pair of bolts and nuts to hold the plate halves together. Four predrilled tabs are provided for this purpose.

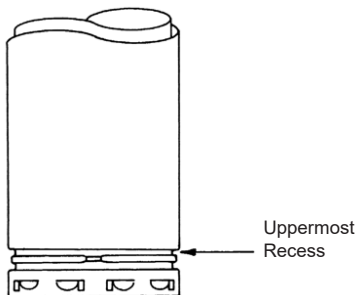

Fig. 34

4. Mounting holes are provided around the perimeter of the Firestop Support Plate. Use appropriate fasteners to secure the Support Plate halves to the opening between floors. (Firestop Support Plates should be attached to the TOP of the opening only). See Figure 36.

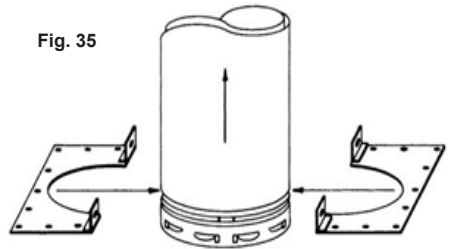

Fig. 35

5. For installations with multiple supports, an Adjustable Length Section of Type B Gas Vent should be installed between each pair of

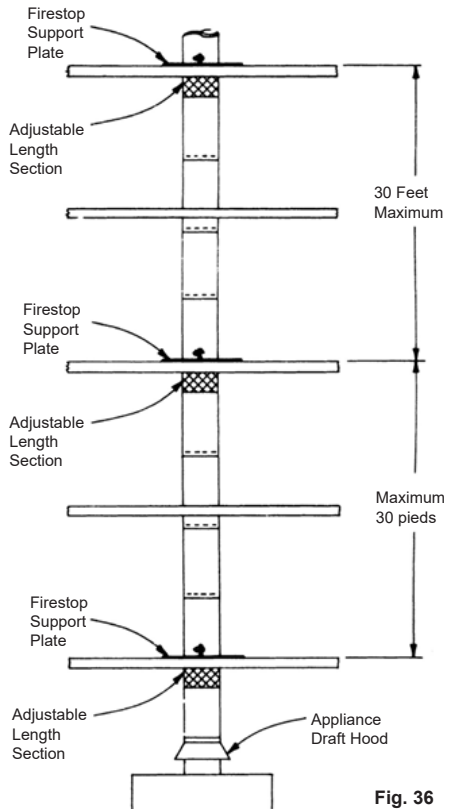

Fig. 36

locations where a support is used (see Figure 36). This allows the location of the pipe recess to be in the proper position at each opening where a support is to be used. The Adjustable Length Section also provides relief for linear thermal expansion. The Adjustable Length Section should be positioned directly under the vent pipe section that is being supported.

Firestop Spacer BVRFS

The Firestop Spacer (BVRFS) is designed to maintain one-inch clearance to combustibles for use with Type B Gas Vent in sizes 10" and 12" diameter when installed as follows.

1. Frame in an opening providing proper clearance to Type B Gas Vent. See Figure 36a and the Framing Chart below.

| Vent Size | "A" Square |
|-----------|---------------|
| 10BV | 13-1/2 inches |
| 12BV | 15-1/2 inches |

2. Secure Firestop Spacer (BVRFS) as shown in Figure 36b using nails through the provided holes.

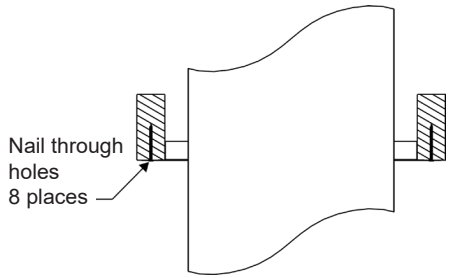

Fig. 36b

3. Pass Type B Gas Vent through opening in Firestop Spacer (BVRFS).

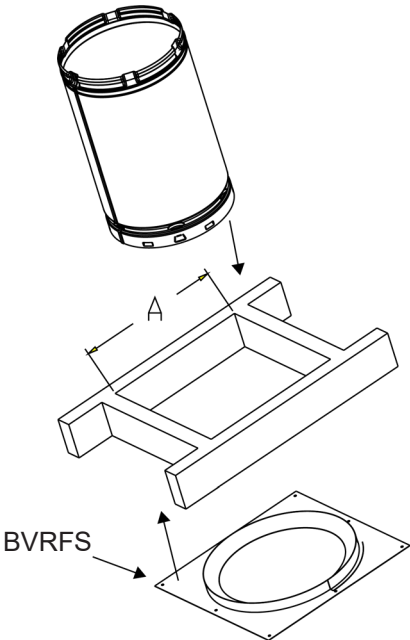

Fig. 36a

TO UNLOCK JOINT

BV GAS VENT JOINT METHOD - 10" and 12" - DURATAB FEATURE

TO LOCK JOINT



1. Line up lance with emboss. Ensure lock seams are not lined up.



2. Push pipe sections together until edge of female end rests on shoulder of male end.



Disengage DuraTab.

Rotate sections until seams are misaligned. Align lances with embosses.



3. Rotate pipe section until seams are aligned.



4. Engage DuraTab into emboss to stop rotation.



Pull sections apart.

BV GAS VENT JOINT METHOD - 14" TO 30"

TO LOCK JOINT

1. Line up seams of both pipes (ensure UP ARROW on label is pointing up or away from the appliance). See Step 1.



Step 1

2. Press down on pipe all the way around until you hear a snap-in-place sound. The pipes are now firmly connected. See Step 2.



Step 2

TO UNLOCK JOINT

3. Pry out all lances (teeth). Rotate joint slightly while gently pulling apart. See Step 3.



Step 3

Adjustable Length Section

An 18" Adjustable Length Section (18A) is available for Large Diameter Type B Gas Vent. It telescopes over fixed lengths to accommodate odd distances or to achieve specific dimensions between vent lengths or connectors. Sizes 10-inch and above are secured using two sheet metal screws equally spaced around the mating section.

Adjustable Length Section may also be used to compensate for linear thermal expansion between two fixed points in the vent system.

Examples of this are shown in Figure 36. In these examples the fastening devices are not used. This allows for expansion between two fixed supports or between a fixed support and the appliance. Note that the fastening means should be left loose only if the Vent and the Adjustable Length Sections are installed vertically. If the Adjustable Length Sections are used in a position other than vertical, such as between offsets, the fastening means should be used. Finally, when joining an Adjustable Length Section to another section of Type B Gas Vent, make sure that there is a minimum overlap of two inches. **DO NOT USE Adjustable Lengths to suspend any weight of pipe below.**

USE OF GAS VENT FITTINGS

Model BV tees, elbows, increasers, and short lengths are specially designed to facilitate interconnections.

Tees used to start vertical vents must use a tee cap to prevent air leakage. All unused openings in a gas vent must be sealed to prevent loss of effective vent action.

A Wall Thimble is available in diameters of 10" and 12" only. It is used where a Type B Gas Vent passes through a vertical wall. The Wall Thimble will provide for the proper clearance to combustible material as the vent passes through the wall, and will also act as a firestop for the vent. **NOTE:** For larger diameters (14" to 30") a Firestop Support Plate (FSP) must be used installed in a fully framed opening at the required air space clearances to combustible materials.

Elbows are used to offset installation to avoid obstructions such as rafters and joists. Diameters 10" to 14" are fully adjustable from 0° to 45°. Diameters 16" to 30" are non-adjustable.

Increasesers

An Increaser is used to make a transition from a smaller vent diameter to a larger vent diameter. The Increaser is available in steps up to a maximum of four (4) sizes larger. For examples:

- A 10-inch diameter can be increased with a single Increaser up to 18-inch;
- A 22-inch diameter can be increased with a single Increaser up to 30-inch.

Tees

Tees are available from 10" to 30" and are designed for breaching or as connectors for vertical, sloped, or horizontal systems. They can also be used to provide access for inspection and cleaning. Tees must be isolated from expansion forces by supporting as needed and with Adjustable Length Sections. Any unused open end of the Tee should be closed off with a Tee Cap.

NOTE An Adjustable 10" Tee with an 8" branch is available. Slide the 8" male end of a rigid Length into the branch. Once in its final position, secure with 3 sheet metal screws (supplied) through the pre-punched holes.

Termination of Vent Structure

Two Termination Caps are available. A High Wind Cap is available for diameters from 10" to 18". The High Wind Cap is designed with the same lock as the female end of vent sections. A Universal Cap is available in diameters of 20" to 30". The Universal Cap is designed to fit inside of the inner wall of vent sections. For 10" and 12" the terminations must terminate in accordance with section 14 and Table 1 (Fig. 16B) on page 15.

Termination of Vent Must be Securely Guyed or Braced if it Extends more than 5 Feet Above Roof

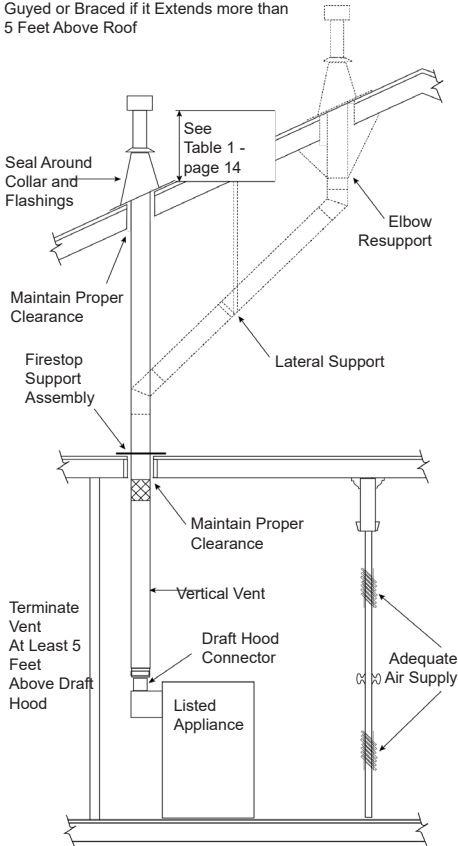

Fig. 37

Whenever the vent is changed from a vertical direction, the vent system must be resupported before and after the change in direction. The support should provide rigid stability, both vertically and horizontally (see Fig. 37). Check with your local Building Officials to make sure any alternative support method is acceptable.

CAUTION
WHERE HEAVY SNOWFALL OCCURS,
THE CAP SHOULD BE INSTALLED
TO MEET THE ABOVE MINIMUM
HEIGHT REQUIREMENTS ABOVE THE
AVERAGE SNOW DEPTH.

Maximum Offset Table in inches

| Dia. | With Two 45° Elbows Only | | | With Two 45° Elbows and: | | | |
|------|--------------------------|--------|--------|--------------------------|--------|--------|--------|
| | A | B | | 12" | 18" | 24" | 36" |
| | 5-7/8 | 5-3/8 | 7-1/4 | | | | |
| 10 | 5-7/8 | 5-3/8 | 7-1/4 | 15 | 19-1/4 | 23-1/2 | 32 |
| 12 | 6 | 5-3/8 | 7-1/4 | 15 | 19-1/4 | 23-1/2 | 32 |
| 14 | 6-5/8 | 6-1/2 | 8-1/2 | 16-1/4 | 20-1/2 | 24-3/4 | 33-1/4 |
| 16 | 7 | 7 | 9-1/4 | 17 | 21-1/4 | 25-1/2 | 34 |
| 18 | 7-9/16 | 7-1/2 | 10 | 17-3/4 | 22 | 26-1/4 | 34-3/4 |
| 20 | 8-1/2 | 8-5/8 | 10-1/4 | 18 | 22-1/4 | 26-1/2 | 35 |
| 22 | 8 | 7-5/8 | 10-1/4 | 18 | 22-1/4 | 26-1/2 | 35 |
| 24 | 8-5/8 | 8-5/16 | 11-1/4 | 19 | 23-1/4 | 27-1/2 | 36 |
| 26 | 9 | 9 | 12 | 19-3/4 | 24 | 28-1/4 | 36-3/4 |
| 28 | 9-1/2 | 9-1/2 | 12-3/4 | 20-1/2 | 24-3/4 | 29 | 37-1/2 |
| 30 | 10 | 10 | 13-1/2 | 25-1/2 | 13-1/2 | 29-3/4 | 38-1/4 |

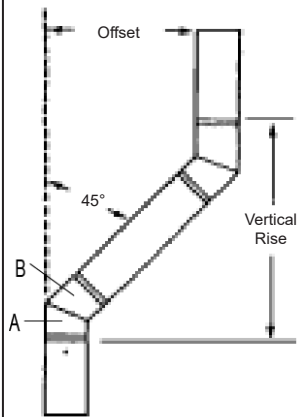

NOTE: The vertical rise can be closely estimated by adding one "A" and one "B" dimension to Maximum Offset

For diameters 14" to 30", the termination must terminate as per Figures 38 and 39.

A cap or chimney housing offers resistance to the entrance of rain, snow and debris, as well as birds, and will minimize the effect of wind on the vent. It will protect the vent from down drafts due to a wind that impinges directly upon the vent. A reminder also to homeowners to check the rain cap for icing during low ambient temperatures.

However, no vent cap, cowl, or top can overcome the adverse effect of a region of high static pressure around the vent terminal or the effect of an interior region of low pressure. Regions of high static pressure around the vent terminal can be avoided by following the general rule for the vent termination given previously. Low or negative interior pressures in the building may be caused by (1) failure to provide for combustion air, (2) excessive use of exhaust fans, and (3) tight construction resulting in the lack of infiltration air.

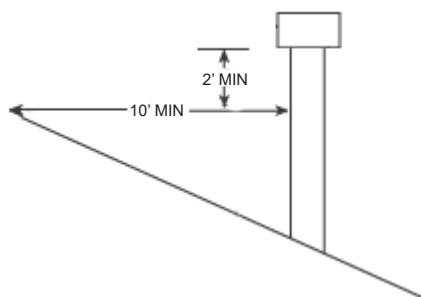

Fig. 38

1. To ensure a waterproof roof structure, use the appropriately sized flashing and storm collar where the vent penetrates the roof. Place the Storm Collar over the vent until it is level. Apply a thick horizontal ring of nonhardening, high-temperature sealant such as silicone, around the vent at the top of the Storm Collar.
2. Vents in excess of 5 feet above the roof should be securely guyed to prevent unnecessary movement. Attach guying to the vent. Never attach guying to the cap.

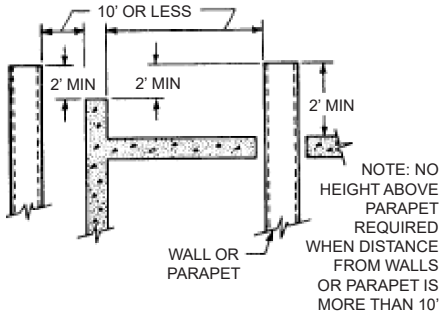

Fig. 39

3. To prolong life and appearance of galvanized steel parts located outside, use proper painting procedure.

- a. Remove oil and dirt with a solvent.
- b. Paint with primer specifically recommended for adhesion to galvanized steel.
- c. Apply finish coat.

Checking Vent Operation

After adjusting appliance and lighting main burner, allow several minutes for warm-up to begin venting action. For water heaters and equipment with draft hoods, hold a lighted match along the rim of the draft hood relief opening of the appliance. Proper venting will draw the flame up or into the draft hood. Improper venting, indicated by escaping or spilling of burned gas, will cause the match to flicker or go out. When consulting Standard NFPA 54 or CSA-B149.1-00., follow procedures for conducting safety inspections of existing appliances and placing equipment in operation, paying particular attention to the section titled Checking the Draft (see Fig. 18).

Painting

For any CAN/ULC-605 applications any exterior exposed gas vent above the roofline will require painting to prolong the life and appearance of the galvanized steel outer casing. Use proper painting procedure at time of installation. Remove oil and dirt with a solvent. Paint first with a good quality zinc primer or other primer recommended for use on galvanized steel. Next apply an appropriate finish coat.

SECTION 3

MODEL BVO - OVAL GAS VENTS - 4" - 5" - 6"

Basic Vent Structure

Model BVO Oval Gas Vent is available in sizes 4, 5, and 6-inch and is listed to UL441. The individual sizes reflect the flow rate capacities equivalent to 4-inch, 5-inch, and 6-inch Round Type B Gas Vent. The joint of the Model BVO Type B Oval Gas Vent takes up one inch when assembled. Model BVO Oval Gas Vent is UL-listed for the following applications and clearances to combustibles as shown in the Table below. NOTE: Model BVO Oval is not approved in Canada.

| Underwriters Laboratories-listed Minimum Clearances to Combustibles | | |
|---|-------|--|
| Oval Description | Type | Minimum Clearance |
| U.S.A. Only Model BVO (UL441) 4", 5" and 6" | B | 1" |
| 4" and 5" (when installed in 2x4 stud wall with other-than-recessed heater) | B 2x4 | Clearances as determined by use of 4OFS or 5OFS firestop spacers at each ceiling level |
| 4" (when installed in 2x4 stud wall with recessed heater) | B-W | Clearances as determined by use of 4OHD ceiling plate spacers, and 4OFS firestop spacers |

Model BVO Oval Type B Gas Vent is available in sizes 4, 5, and 6-inch, and requires a 1-inch clearance to combustibles. This includes all Vent Sections, Elbows, Tees, and Adapters. When used as Type B Gas Vent, Model BVO Oval Gas Vent must follow all of the same requirements as round Type B Gas Vent, such as the necessity of using firestops at each floor level. See Section 1.

Type B 2 x 4 Gas Vent - 4" or 5" Oval

Four- and five-inch Model BVO Oval Gas Vent may be installed within a standard 2x4 stud wall if all the following conditions are met.

1. Arrows on parts should always point up.
2. Stud bay must be a 16-inch, on-center stud bay.
3. 2x4 studs must be a minimum of 3.5 inches deep.
4. There must be nothing else in the stud bay other than the Vent Section. This includes any type of insulation.
5. The Firestop Spacer (FS) must be installed at each floor level. See Figure 40.

NOTE: Only the straight Vent Pipe Sections, with or without the Oval Tee, may be used inside the stud bay with reduced clearances to combustibles. See Figure 40.

Type B 2x4 Installation

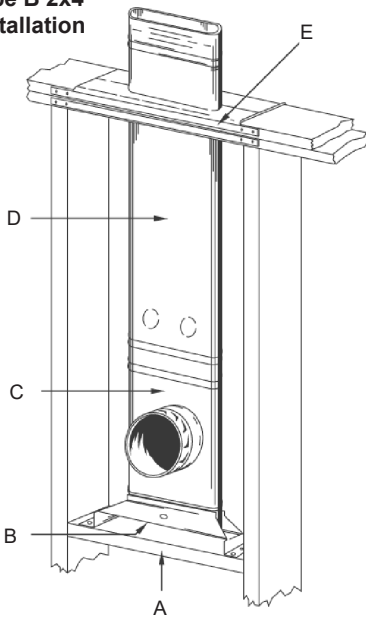

Fig. 40

Installation of Type B 2 x 4 Gas Vent

1. Cut out the ceiling plate in the space where the Vent is to be installed.
2. Nail a 2x4 support (A) at the desired height between the studs. See Figure 40.
3. Attach the Tee Support (B), the Tee (C)

with the Oval Tee Cap, and the Vent Pipe (D) as shown on Figure 40.

4. At each floor level above the Tee, install the Firestop Spacer (E) seen in Figure 40.

NOTE: Provide at least a 1-inch clearance around the Tee branch where it passes through combustible wall.

Type B-W Gas Vent - 4" Oval

Model BVO Oval Gas Vent may be installed within a standard 2x4 stud wall if all the following conditions are met.

1. Arrows on parts should always point up.
2. Stud bay must be a 16-inch, on-center stud bay.
3. 2x4 studs must be a minimum of 3.5 inches deep.
4. There must be nothing else in the stud bay other than the Vent and furnace. This includes any type of insulation.
5. The installation must contain an Oval Hold-Down Plate (4OHD) at the base, Oval Plate Spacers (4OPS) at the first ceiling level, and Firestop Spacers (4OPS) at any additional floor levels. See Figures 41 and 42.

Installation of Type B-W Gas Vent

1. Cut out the ceiling plate at the floor level above the heater flush with studs in space where Vent is to be installed.
2. Nail one Plate Spacer (4OPS), (A), across cut-out area in ceiling plate. See Figure 41. Plate Spacer (4OPS) is required at the first ceiling level above a wall furnace to center and space vent properly and to provide the required opening between floors.
3. Snap Hold-Down Plate (4OHD), (B), onto bottom end of pipe as shown in Figure 41. Install Vent Section in position. Use two No. 8 binder head sheet metal screws to attach Hold-Down Plate firmly to Furnace header plate through pre-punched holes.
4. Nail second Plate Spacer across cutout ceiling plate as shown in Figure 41. Firestop Spacers (OFS) must be used at subsequent levels.
5. If the Vent is to continue additional stories within a 2x4 stud space, install Firestop Spacers at the second and subsequent ceiling levels as shown in Figure 42.

6. After passing through the last Firestop Spacer, the Vent may be finished with either round or oval fittings, flashings and Cap. (Round pipe, fittings, flashings, and vent caps cost less than corresponding oval parts.)

Type B-W Installation

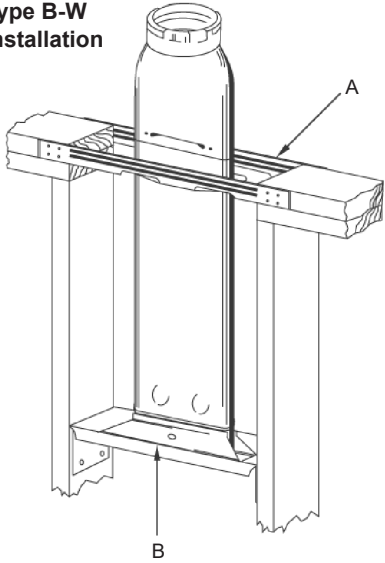

Fig. 41

Multi-Story Type B-W Installations

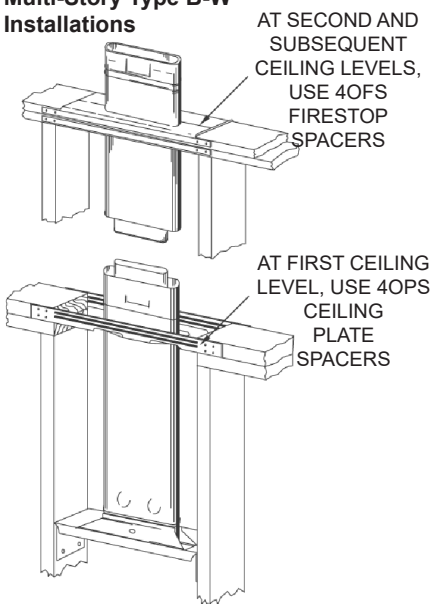

Fig. 42

Attic Insulation Shield

In some areas, the building code requires the use of an attic insulation shield (AVS) on single-story Type B-W installations.

Model BVO Attic Insulation Shield attaches to the top surface of the ceiling plate where oval wall-heater vent enters the attic. The shield prevents mass-type insulation (rock-wool, vermiculite, etc.) from filling or obstructing the ventilated stud space above the heater.

STEP 1:

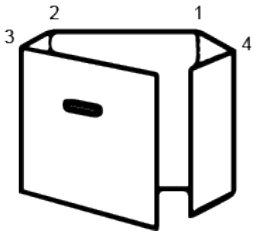

Fold along perforations into rectangular shape with spacer beads on inside.

STEP 2:

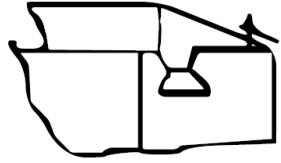

Lock by bending tabs outward. Be sure small flap is on outside as shown.

STEP 3:

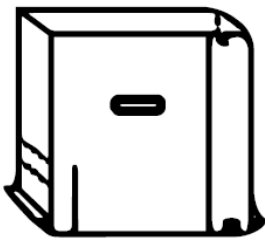

Bend end flanges out along perforations to fit type of constructions (see above).

STEP 4:

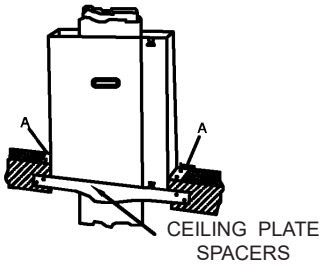

Rectangular end flanges (A) are bent along perforations to fit 2" x 4", 2" x 6" or 2" x 8" joists as required. Make sure bottom edge of shield rests on or overlaps ceiling plate spacers.

Locking of Joints

1. Place female coupler over preceding male coupler.

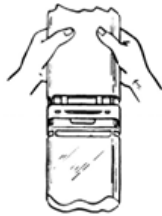

2. Press side of pipe down until joint seats.



3. Press other side of pipe down until joint is engaged.



Unlocking of Joints

1. Insert screwdriver one inch into joint as shown.



2. Press firmly inward with blade of screwdriver and pry upwards VERY SLOWLY AND GENTLY. Joint will slowly separate without damage.



DuraVent Limited Lifetime Warranty

DuraVent, Inc. ("DuraVent") provides this limited lifetime warranty for all of its products with the exception of Ventinox® (lifetime), and PolyPro® (ten years). Subject to the limitations set forth below, DuraVent warrants that its products will be free from defects in material or manufacturing, if properly installed, maintained and used. DuraVent products are fully warranted if installed only by a professional installer. This Warranty is transferable from the original homeowner to the buyer of the home. This warranty does not cover normal wear and tear, smoke damage or damage caused by chimney fires, acts of God, or any product that was: (1) purchased other than from an authorized DuraVent dealer, retailer or distributor; (2) modified or altered; (3) improperly serviced, inspected or cleaned; or (4) subject to negligence or any use not in accordance with the installation instructions included with the product as determined by DuraVent. Installation instructions are available online at www.duravent.com under Support/Literature and through our Customer Service Department 800-835-4429 or customerservice@duravent.com. This limited lifetime warranty applies only to parts manufactured by DuraVent.

DuraVent provides the following warranties for its products: One Hundred Percent (100%) MSRP 15 years from the date of purchase, and Fifty Percent (50%) thereafter, except for the following limitations on: all Termination Caps and DuraBlack® are warranted at One Hundred Percent (100%) for five years.

All warranty obligations of DuraVent shall be limited to repair or replacement of the defective product pursuant to the terms and conditions applicable to each product line. These remedies shall constitute DuraVent's sole obligation and sole remedy under this warranty. This warranty provides no cash surrender value. The terms and conditions of this warranty may not be modified, altered or waived by any action, inaction or representation, whether oral or in writing, except upon the express, written authority of an executive officer of DuraVent.

Corn, bio-fuels, driftwood or other wood containing salt, preservative-treated lumber, plastic and household trash or garbage, or wood pellets containing such materials must not be burned in the appliance or fireplace. In case of a chimney fire, the chimney must be inspected and approved by a certified Chimney Sweep before reuse. After each annual inspection, maintenance, and cleaning, the certified Chimney Sweep must fill out and date the appropriate section of the warranty card provided with the chimney liner.

LIMITATIONS ON INTERNET SALES: Notwithstanding any other terms or conditions of this Limited Lifetime Warranty, DuraVent provides no warranty for the following specific products if such products are not installed by a qualified professional installer: DuraTech®, DuraTech® DTC, DuraPlus HTC®, DuraTech® Premium, DDW®, DuraChimney® II, DuraPlus Canada 2, PelletVent Pro®, DirectVent Pro®,

FasNSeal®, FasNSeal® W2, FasNSeal® Flex, and PolyPro®, and DuraVent's relining products including DuraLiner®, DuraFlex® (SW, Pro, 316, 304), and Ventinox®. For purposes of this warranty, a trained professional installer is defined as one of the following: licensed contractors with prior chimney installation experience, CSIA Certified Chimney Sweeps, NFI Certified Specialists, or WETT Certified Professionals.

DuraVent must be notified and given the opportunity to inspect defective product prior to replacement under the terms of this limited lifetime warranty. All warranty claims must be submitted with proof of purchase. Labor and installation costs are not covered under this warranty. To obtain warranty service contact: DuraVent Warranty Service, 877 Cotting Ct., Vacaville CA 95688, or call 800-835-4429.

WHERE LAWFUL, DURAVENT DISCLAIMS ALL OTHER WARRANTIES, INCLUDING BUT NOT LIMITED TO IMPLIED WARRANTIES OF MERCHANTABILITY AND FITNESS FOR A PARTICULAR PURPOSE. IN NO EVENT WILL DURAVENT BE LIABLE FOR INCIDENTAL, CONSEQUENTIAL, PUNITIVE OR SPECIAL DAMAGES OR DIRECT OR INDIRECT LOSS OF ANY KIND, INCLUDING BUT NOT LIMITED TO PROPERTY DAMAGE AND PERSONAL INJURY. DURAVENT'S ENTIRE LIABILITY IS LIMITED TO THE PURCHASE PRICE OF THIS PRODUCT. SOME STATES DO NOT ALLOW LIMITATIONS ON IMPLIED WARRANTIES, OR THE EXCLUSION OR LIMITATION OF INCIDENTAL OR CONSEQUENTIAL DAMAGES, SO THE ABOVE LIMITATIONS AND EXCLUSIONS MAY NOT APPLY TO YOU. THIS LIMITED WARRANTY GIVES YOU SPECIFIC LEGAL RIGHTS, AND YOU MAY ALSO HAVE OTHER RIGHTS THAT VARY FROM STATE TO STATE.

For the most up-to-date installation instructions, see www.duravent.com

duravent™