

INSTALLATION AND MAINTENANCE INSTRUCTIONS

Dura Stack® Pro Series

- Boiler Stack
- Engine Exhaust
- Grease Duct
- Zero Clearance Grease Duct

DCL

- Boiler Stack
- Engine Exhaust
- Grease Duct
- Chimney Liner



MODEL DCL



MODEL DAS1



MODEL DIS1



MODEL DIS2



MODEL DIS4



MODEL DIS3Z

MODEL	DCL	Single Wall
	DAS1	Air Insulated
	DIS1, DIS2, DIS4, DIS3Z	FiberInsulation

This installation manual will enable you to obtain a safe, efficient and dependable installation of this chimney system. Please read and understand these instructions before beginning your installation.

Do not alter or modify the components of this chimney system under any circumstances. Any modification or alteration of the chimney system or approved accessories, including but not limited to the appliance it is connected to, may void the warranty, listings and approvals of this system and could result in an unsafe and potentially dangerous installation.

- Examine all components for possible shipping damage prior to installation.
- Proper joint assembly is essential for a safe installation. Follow these instructions exactly as written: Check severeness of joints upon completion of assembly.
- This venting system must be free to expand and contract. This venting system must be supported in accordance with these instructions.
- Check for unrestricted vent movement through walls, ceilings, and roof penetrations.
- Different manufacturers have different joint systems and adhesives. Do not mix pipe, fittings, or joining methods from different manufacturers.

**SAVE THESE INSTRUCTIONS
FOR FUTURE REFERENCE**

WARNINGS

FAILURE TO FOLLOW THESE INSTALLATION INSTRUCTIONS COULD CAUSE FIRE, CARBON MONOXIDE POISONING, OR DEATH. IF YOU ARE UNSURE OF INSTALLATION REQUIREMENTS, CALL THE PHONE NUMBER LISTED ON THE BACK OF THESE INSTRUCTIONS.

A MAJOR CAUSE OF CHIMNEY RELATED FIRE IS FAILURE TO MAINTAIN REQUIRED CLEARANCES (AIR SPACES) TO COMBUSTIBLE MATERIALS. IT IS OF UTMOST IMPORTANCE THAT THIS CHIMNEY BE INSTALLED ONLY IN ACCORDANCE WITH THESE INSTRUCTIONS.



LISTED
MH 61322
MH 62023
MH 14420
R39469

Listed to Standards:

UL 103
UL 103HT
ULC 604
ULC/ORD C959
UL 1978
UL 2221 - DIS3Z only
CAN/ULC S662
UL 2561 - except DIS3Z
UL 1777 - DCL only
CAN/ULC S635

TABLE OF CONTENTS

INTRODUCTION	2	SECTION G - TERMINATION, STARTING ADAPTERS, DRAINING SECTIONS, RELIEF VALVE AND ACCESSORIES	29
SECTION A - CODE COMPLIANCE	3	TERMINATION - GENERAL	29
LISTING	3	Finishing Cone (FC).....	29
APPLICATIONS	3	Rain Cap (RC) or Rain Cap with Bird Screen (CRCB) ..	29
MULTI-ENGINE EXHAUSTS	3	Flip Top (FT)	29
ADDITIONAL APPLICATIONS	3	Miter Cut (MC)	29
MIXING PARTS	3	No Loss Cap (NLC).....	29
PRODUCT LABELS	4	DRAINING SECTIONS	30
SECTION B - GENERAL INFORMATION	5	Drain Length (DL).....	30
PART NUMBERS	5	Horizontal Length (HDL).....	30
EFFECTIVE LENGTH AND THICKNESS	5	Nozzle Length (NL)	30
CLEARANCE	5	RELIEF VALVE FOR EXCESSIVE PRESSURE	30
OPENING THROUGH CONSTRUCTION.....	6	Relief Valve (RV)	30
SYSTEM SIZING	6	APPLIANCE AND FLANGE CONNECTIONS	31
SLOPE FOR GREASE DUCT APPLICATION.....	6	Single Wall Adaptor (SWA)	31
FREIGHT DAMAGE	7	Single Wall Adaptor With Nozzle (SWAN)	31
PROPER STORAGE	7	Ansi Flange Adaptor (FA).....	32
PRODUCT WEIGHTS	7	Half Universal Flange (HUF).....	32
THERMAL EXPANSION CALCULATIONS	7	DAMPER LENGTH	33
SUPPORT METHODS AND HEIGHT LENGTHS	7	Damper Length (DAMPLXX).....	33
GUYING AND BRACING	8	SECTION H - GREASE DUCT SPECIFIC COMPONENTS	34
EXTERIOR CORROSION PROTECTION	8	STRAIGHT SECTIONS	34
SIEMIC REQUIREMENTS	8	Horizontal Drain Length (HDL)	34
PRODUCT INSPECTION	8	Nozzle Length (NL)	34
SECTION C - PIPE AND FITTING ASSEMBLY	9	No Tool Inline Access Door (ADL24 or ADL36)	35
Special Feature	9	Drain Bucket (DB)	36
Joint Assembly	9	No Tool Access Tee Cap (NTTC)	36
Sealant Usage.....	10	TEES	37
SECTION D - COMPONENTS	11	90° Tees (T90) and Grease Tee with dam (T90D) ..	37
ODD LENGTH AND EXPANSION HIGH PRESSURE SYSTEM	11	Tees with nozzle (T90N)	37
Bellow Length (LB)	11	Y Tee (TY)	37
Adjustable Length (LA)	12	ADAPTERS	38
Variable Length (LV)	14	Round Flanged Hood Adapter (RFHA)	38
TEES	17	Square To Round Adapter (STR)	38
90° Tee (T90).....	17	Eccentric Square To Round Adapter (ESTR)	39
45° Tee (T45) and Double 45° Tee (TD45)	17	Square To Round Adapter (STR)	39
Lateral Tee (BT)	17	SECTION I - GREASE DUCT LOCATION OF SUPPORTS.....	40
Tee Cap (TC)	18	Adjustable and Length Support	40
Drain Tee Cap (DTC)	18	Tee Support.....	40
ELBOWS	19	Elbow Support	40
Elbows (E3, E15, E30, E45, E90)	19	Through Fire Rated Floor/Ceiling Support (CIX3Z ONLY) ..	41
INCREASERS AND REDUCERS	21	Through Wall Support	41
Tapered Increaser (TINØ)	21	SECTION J - GREASE DUCT FIRE-RATED FLOOR, ROOF AND WALL PENETRATION (CIX3Z ONLY)	42
Eccentric Tapered Increaser (ETINØ)	21	Through Penetration Firestop Kit (TPFK).....	42
Step Increaser (INØ)	21	SECTION K - GREASE DUCT WALL, FLOOR AND ROOF PENETRATION, GUYING AND BRACING	43
PLATE AND WALL SUPPORTS	21	Roof Thimble (RT).....	43
Anchor Plate (AP)	21	Wall Thimble (WT).....	43
Anchor Plate with Length (APL)	22	Through Wall Support	43
Heavy Duty Wall Support (WSHD)	23	SECTION L - GREASE DUCT TERMINATION	44
Heavy Duty Wall Guide (WGHD)	23	SECTION M - GREASE DUCT MAINTENANCE	44
Heavy Duty Floor Guide (FGHD)	23	SECTION N - GREASE DUCT & WOOD OVEN	44
Full Angle Ring (FAR).....	23	SECTION O - SAMPLE DRAWINGS.....	45
Half Angle Ring (HAR).....	23	SECTION P - CHIMNEY LINERS	48
SECTION E - LOCATION OF SUPPORTS	24		
ADJUSTABLE AND VARIABLE LENGTH SUPPORT	24		
TEE SUPPORT	24		
ELBOW SUPPORT	25		
SECTION F - WALL, FLOOR AND ROOF PENETRATION, GUYING AND BRACING	25		
Roof Thimble (RT).....	25		
Wall Thimble (WT).....	26		
THROUGH WALL SUPPORT	26		
Flashing (F).....	26		
Adjustable Flashing (F30)	26		
GUYING AND BRACING	27		

NOTE: Dimensions in these instructions are in American standard (feet and inches), with Metric (mm) in parenthesis except where stated otherwise.

WARNING!

Failure to follow these installation instructions could cause FIRE, CARBON MONOXIDE, POISONING, OR DEATH. If you are unsure of Installation requirements, call Phone Number listed on the front of these instructions.

Caution-Risk of injury. Sheet metal parts may be sharp. Always wear gloves and appropriate eye, foot, and other protection when handling these products. The use or substitution of materials other than as specified in these instructions is not recommended, as they could affect the safety and performance of the system. Before starting an installation of a chimney or liner system, consult the Local Building or Fire Officials about any Restrictions and specific Installation Inspection in your area.

SECTION A - CODE COMPLIANCE

UNDERWRITERS LABORATORIES LISTINGS

Duravent single wall Model DCL and double wall models DAS1, DIS1, DIS2, DIS4 and DIS3Z venting systems are Listed by Underwriters Laboratories, Inc. (UL) in the following product categories and in the diameters indicated:

Model DCL (Single wall)	
UL 103 - Building Heating Appliance Chimney	5"- 36" ID
UL 1978 - Grease Duct CAN/ULC S662 - Grease Duct	5"- 36" ID
UL 1777 - Chimney Liner - Gas/Oil	5"- 36" ID
CAN/ULC S635 - Chimney Liner for Existing Masonry & Factory-Built Chimneys	5"- 36" ID
UL 2561 & ULC/ORD C959 - 1400° Fahrenheit Chimney	5"- 36" ID
Model DAS1 (Double wall, 1" air insulation)	
UL 103 & ULC 604 - Building Heating Appliance Chimney	5"- 36" ID
UL 2561 & ULC/ORD C959 - 1400° Fahrenheit Chimney	5"- 36" ID
UL 1978 - Grease Duct CAN/ULC S662 - Grease Duct	5"- 36" ID
Model DIS1, DIS2, DIS4 (Double wall, fiber insulation)	
UL 103 & ULC 604 - Building Heating Appliance Chimney	5"- 36" ID
UL 103 HT - Building Heating Appliance Chimney(Type HT)	5"- 24" ID
UL 2561 & ULC/ORD C959 - 1400° Fahrenheit Chimney	5"- 36" ID
UL 1978 - Grease Duct CAN/ULC S662 - Grease Duct	5"- 36" ID
Model DIS3Z (Double wall, fiber insulation)	
UL 1978 - Grease Duct	5"- 36" ID
UL 2221 - Fire Resistant Enclosure	5"- 36" ID
CAN/ULC S662 - Grease Duct	5"- 36" ID

APPLICATIONS

UL 103 & ULC 604 Building Heating Appliance Chimney Listing: Under this category, Models DCL (UL 103 ONLY), DAS1, DIS1, DIS2, and DIS4 have been determined suitable for venting flue gases at temperatures not exceeding 538°C (1000°F) under continuous operating conditions from gas, liquid, oil or solid fuel (UL 103 ONLY) fired appliances. Also complies with operation (less than one hour) at temperatures not exceeding 740°C (1400°F) and brief operation (maximum 10 minutes) at temperatures not exceeding 906°C (1700°F). Building Heating Appliance Chimneys are suitable for use with Building Heating Appliances and Low Heat Appliances as described in the Chimney Selection Chart of National Fire Protection Association (NFPA) Standard NO. 211.

UL 103HT Building Heating Appliance Chimney Listing: Under this category (UL 103HT), Models DIS1, DIS2 and DIS4 - up to 24" I.D. have qualified for UL's additional, optional "Type HT" rating (for Building Heating Appliance Chimneys) which indicates they have been evaluated and found suitable for exposure to 2100°F flue gases for a 10 minute duration at a specific clearance for each Model and diameter. Many local, state and regional code authorities require a "Type HT" rating for chimneys for certain appliance venting applications, especially solid fuel.

For solid fuel application, a maximum of 30 degree deviation from the vertical is allowed. Building Heating Appliance Chimneys are suitable for use with Building Heating Appliances and other Low Heat Appliances as described in the Chimney Selection Chart of National Fire Protection Association (NFPA) Standard No. 211.

1400°F Chimney Listing: Under this category (UL 2561, ULC/ORD-C959), DCL, DAS1, DIS1, DIS2 and DIS4 have been determined suitable for venting flue gases continuously at a temperature not exceeding 1400°F, and a 10 minute intermittent service at temperatures not exceeding 1800°F. As such, Models DCL, DAS1, DIS1, DIS2 and DIS4 are suitable for use with ovens and furnaces as described in the Chimney Selection Chart of NFPA No. 211, in addition to other Applications.

UL 1978 Grease Duct (DCL, DAS1, DIS1, DIS2, DIS4, DIS3Z) Listing: Duravents Grease Ducts are listed for continuous temperatures of 500°F and intermittent temperatures of up to 2000°F, and are ideally suited for use in commercial cooking installations for the removal of smoke and grease laden vapors (Type I or Type II kitchen exhaust hood). Grease duct system size and capacity information may be obtained from the "ASHRAE Handbook - Fundamentals" or from the "Air Pollution Engineering Manual" of the "US Environmental Protection Agency."

UL 2221 Listing: Model DIS3Z is classified in accordance with UL 2221 (Tests of Fire Resistant Duct Enclosure Assemblies) as an alternate to a 2-Hr. fire resistant shaft enclosures with a minimum zero clearance to combustibles (sizes 5" to 36" diameters). Model DIS3Z has been evaluated in accordance with the requirements for duct enclosure Condition A.

UL 1777 & CAN/ULC S635 Listing: Under this category, Model DCL, Class 2 chimney liners have been determined suitable in new (US only) or existing masonry chimneys or Factory-Built Chimneys. Use only with appliances burning oil and gas only. Lining systems must be installed in accordance with Manufacturer's Installation Instructions. The liner is to be installed in a masonry chimney where there is a minimum clearance of 1" of air space between combustibles materials and the masonry chimney exterior.

ENGINE EXHAUST APPLICATIONS

Based upon the above referenced UL Listings and supplemental, UL confirmed pressure testing, Models DCL, DAS1, DIS1, DIS2 and DIS4 are also suitable for use as complete exhaust systems for diesel engine and gas turbines. When Models DCL, DAS1, DIS1, DIS2 and DIS4 is used as an engine or turbine exhaust it is intended to be installed in accordance with NFPA 37 "Stationary Combustion Engines and Gas Turbines". This code states, "When such (flue gas) temperatures do not exceed 1000°F (538°C) except for infrequent, brief periods, the engines shall be classified as low heat appliances". For continuous operation over 1000°F and not exceeding 1400°F the exhaust system should be installed as a 1400°F Chimney.

- Models DIS1, DIS2, and DIS4 may be used to meet various needs, such as:
- Reduce outer pipe surface temperature.
 - Reduce building heat gain by retaining energy inside the duct.
 - Increase the efficiency of energy recovery systems by reducing exhaust gas temperature losses.
 - Increase chimney or exhaust system draft loss performance due to reduced exhaust gas temperature drop.
 - Reduce building noise levels caused by high speed or pulsating exhaust induced noise. NOTE: Specific tests have not been conducted to measure acoustic performance.

Models DCL, DAS1, DIS1, DIS2 and DIS4 exhaust systems are intended for use in connecting the heating appliance, engine, or turbine to the outdoors, while operating under positive forced draft, negative induced draft or neutral gravity flow internal pressure conditions.

Multi-Engine Exhausts

A common exhaust system for multiple engine or turbine installations is generally not recommended. Check with your engine or turbine manufacturer prior to common exhaust system design. Exhaust gas from operating units tends to flow to non-operating units where condensation may form. Water in engine or turbines at start-up may cause damage. In general, a separate exhaust system should be provided for each engine or turbine.

ADDITIONAL APPLICATIONS

Models DCL, DAS1, DIS1, DIS2 and DIS4 are also suitable for negative, neutral or positive pressure pre-fabricated piping systems intended for use in a variety of applications including but not limited to the following: Fume Venting, Chutes, Particle Conveying, Dryer Vents and Ventilation Ducts.

SUITABLE FOR POSITIVE PRESSURE VENTING APPLICATIONS WITH MAXIMUM 60" WATER COLUMN INTERNAL STATIC PRESSURE AT MAXIMUM 1400°F.

MIXING PARTS

Model DCL, DAS1, DIS1, DIS2, DIS4 and DIS3Z may be intermixed within a system, assuming proper clearances are maintained for respective components. When penetrating a roof, appropriate roof penetration components must be used. Do not use Model DCL to penetrate through a wall, floor or roof.

PRODUCT LABELS

DuraStack PRO
MODELS: DAS1 / DIS1 / DIS2 / DIS4

UL LISTED MH10971

FACTORY BUILT CHIMNEY SYSTEM PART LISTED AS / Cheminée Préfabriquée Homologuée:
 - BUILDING HEATING APPLIANCE CHIMNEY / Cheminée pour appareil de chauffage
 - INDUSTRIAL 1000°F (540°C) OR LESS CHIMNEY / Cheminée Industrielle 540°C ou moins
 - INDUSTRIAL 1400°F (760°C) OR LESS CHIMNEY / Cheminée Industrielle 760°C ou moins
 UL-103, UL-103HT (Ø5 to Ø24 for DIS1, DIS2, DIS4), UL-2561, ULC-S604, ULC-C959

For Venting Solid (US only), Liquid and Gas-Fired Appliance / Pour évacuer Combustible Solide (US seulement), Liquide et Gaz

CAUTION: DO NOT ENCLOSE WITH COMBUSTIBLE MATERIALS. RISK OF FIRE.

RATED FOR USE AT MAXIMUM 60 INCH WATER COLUMN INTERNAL PRESSURE WHEN USED IN POSITIVE PRESSURE APPLICATION. ALWAYS FOLLOW INSTALLATION INSTRUCTION FROM DuraVent Inc.

SUITABLE FOR EXTERIOR AND INTERIOR INSTALLATION

ATTENTION: NE PAS ENFERMER DANS UNE ENCEINTE COMBUSTIBLE.

CLASSE POUR UNE UTILISATION A PRESSION POSITIVE INTERNE MAXIMALE DE 60 POUCES DE COLONNE D'EAU

TOUJOURS SUIVRE LE MANUEL D'INSTALLATION DE DuraVent Inc.

UTILISABLE A L'EXTÉRIEUR ET A L'INTÉRIEUR

UP HAUT
 FLOW DIRECTION ECOULEMENT

Minimum Air Space Clearances to Combustible material and building insulation for 1000°F (540°C) and 1400°F (760°C) continuous temperature Chimney System
 Dégage minimum aux matériaux combustibles / isolants de bâtiment pour hotte évacuant vapeur à une température de 500°F (260°C) en continu.

Duct Model	Flue Diameter Ø (in)	Clearance to Combustible (in)
DAS1	Ø5 to Ø5	4
	Ø7 to Ø14	5
	Ø16 to Ø22	6
	Ø24 to Ø30	7
	Ø32 to Ø36	8
DIS1	Ø5 to Ø5	1
	Ø7 to Ø14	2
	Ø16 to Ø22	3
(UL 103 Type HT Ø5 to Ø24 only)	Ø16 to Ø30	4
	Ø32 to Ø36	5
DIS2 & DIS4	Ø5 to Ø14	1
	Ø16 to Ø30	2
(UL 103 Type HT Ø5 to Ø24 only)	Ø32 to Ø36	3

LAVAL, QC CANADA NP344 REV.1

UL LISTED MH45179

GREASE DUCT PART, FOR RESTAURANT COOKING APPLIANCE
 LISTED IN ACCORDANCE WITH UL-1978 TEST STANDARD.
 GREASE DUCT FOR USE IN GREASE DUCT ASSEMBLIES, CLASSIFIED IN ACCORDANCE WITH UL-2221. SEE UL FIRE RESISTANCE DIRECTORY NO. R37874.

CONDUIT D'ÉVACUATION POUR HOTTE DE CUISINE COMMERCIALE
 LISTÉS SELON LA NORME UL-1978 ET CLASSIFIÉS SELON LA NORME UL-2221.
 VOIR LE RÉPERTOIRE SUR RÉSISTANCE AU FEU DE UL NO. R37874.

MODEL DIS3Z MODÈLE

GREASE DUCT, FOR USE IN GREASE DUCT ASSEMBLY NO. G-20 CLASSIFIED AS AN ALTERNATE TO 2 HR. FIRE RESISTIVE SHAFT ENCLOSURE WITH A MINIMUM ZERO CLEARANCE (AIR SPACE) TO COMBUSTIBLES.
 FLUE DIAMETER: Ø5" to Ø36"

CONDUIT DE GRASSE, POUR UTILISATION D'ASSEMBLAGE DE CONDUITS DE GRASSE NO. G-20, CLASSÉ COMME ÉTANT UNE ALTERNATIVE À UN BOISER RÉSISTANT AU FEU DURANT 2 HEURES INSTALLÉ AUTOUR DU CONDUIT, AVEC UN DÉGAGEMENT MINIMALE DE ZÉRO POUCE AUX MATÉRIELS COMBUSTIBLES.
 DIAMÈTRES DE LA PAROI INTÉRIEURE: Ø5" À Ø36"

UP HAUT
 FLOW DIRECTION ECOULEMENT

FOR GREASE DUCT SYSTEMS INSTALLED WITHOUT A CONTINUOUS FIRE-RATED ENCLOSURE, AN EVALUATED THROUGH-PENETRATION FIRESTOP ASSEMBLY SHALL BE USED.

SEE THROUGH-PENETRATION FIRESTOP SYSTEM NO. C-AJ7160 IN UNDERWRITERS LABORATORIES INC. FIRE RESISTANCE DIRECTORY FOR RATED INSTALLATIONS THAT REQUIRE PENETRATION OF RATED WALLS OR FLOORING.

CAUTION: RISK OF FIRE. DO NOT FULLY ENCLOSE WITH COMBUSTIBLE MATERIALS.
 INSTALLED AND USE ONLY IN ACCORDANCE WITH SECURITY CHIMNEYS INTERNATIONAL LTD GREASE DUCT INSTALLATION AND MAINTENANCE INSTRUCTIONS.
 SUITABLE FOR EXTERIOR AND INTERIOR INSTALLATION

CONDUIT DE GRASSE, POUR UTILISATION D'ASSEMBLAGE AVEC RÉSISTANCE AU FEU DURANT 2 HEURES INSTALLÉ AUTOUR DU CONDUIT, AVEC UN DÉGAGEMENT MINIMALE DE ZÉRO POUCE AUX MATÉRIELS COMBUSTIBLES.
 Ø" (TOUS LES DIAMÈTRES)
 DÉGAGEMENT AUX MATÉRIELS COMBUSTIBLES:
 0" (TOUS LES DIAMÈTRES)
 POUR LES CONDUITS INSTALLÉS SANS ENCEINTE AVEC RÉSISTANCE AU FEU, UN COUPE-FEU CERTIFIÉ DOIT ÊTRE UTILISÉ.
 VOIR SYSTÈME DE COUPE-FEU POUR PÉNÉTRATION NO. C-AJ7160 DANS LE RÉPERTOIRE DE RÉSISTANCE AU FEU DE UNDERWRITERS LABORATORIES INC. POUR LES INSTALLATIONS AYANT BESOIN DE PÉNÉTRER À TRAVERS UN MUR, PLANCHER OU PLAFOND AYANT UNE RÉSISTANCE AU FEU.
 ATTENTION: RISQUE DE FEU. NE PAS ENFERMER DANS UNE ENCEINTE COMBUSTIBLE.
 TOUJOURS SUIVRE ET INSTALLER SELON LE MANUEL D'INSTALLATION FOURNI PAR CHEMINEES SECURITE INTERNATIONALE LTD.
 POUR INSTALLATION EXTÉRIÈRE ET INTÉRIÈRE

LAVAL, QC CANADA NP333 REV. 01

UL LISTED MH45179

GREASE DUCT PART, FOR RESTAURANT COOKING APPLIANCE
 LISTED IN ACCORDANCE WITH UL-1978 and ULC-S662 TEST STANDARD.
 GREASE DUCT FOR USE IN GREASE DUCT ASSEMBLIES

CONDUIT D'ÉVACUATION POUR HOTTE DE CUISINE COMMERCIALE
 LISTÉS SELON LA NORME UL-1978 ET ULC-S662

MODELS - DCL / DAS1 / DIS1 / DIS2 / DIS4 - MODÈLES

CAUTION: RISK OF FIRE. DO NOT FULLY ENCLOSE WITH COMBUSTIBLE MATERIALS.
 FLUE DIAMETER: Ø5" to Ø36"

INSTALLED AND USE ONLY IN ACCORDANCE WITH DURAVENT INC. GREASE DUCT INSTALLATION AND MAINTENANCE INSTRUCTIONS.

SUITABLE FOR EXTERIOR AND INTERIOR INSTALLATION

ATTENTION: RISQUE DE FEU. NE PAS ENFERMER DANS UNE ENCEINTE COMBUSTIBLE.

DIAMÈTRES DE LA PAROI INTÉRIÈURE: Ø5" À Ø36"

TOUJOURS SUIVRE ET INSTALLER SELON LE MANUEL D'INSTALLATION FOURNI PAR DURAVENT INC.

POUR INSTALLATION EXTÉRIÈRE ET INTÉRIÈRE

UP HAUT
 FLOW DIRECTION ECOULEMENT

Minimum Air Space Clearances to Combustible material and Building insulation for 500°F (260°C) continuous temperature grease duct system.
 Dégage minimum aux matériaux combustibles / isolants de bâtiment pour hotte évacuant vapeur à une température de 500°F (260°C) en continu.

Flue Diameter Ø (in)	DCL	DAS1	DIS1	DIS2 and DIS4
Ø5	18"	4"	2"	1"
Ø5 to Ø11	18"	5"	2"	1"
Ø12 & Ø13	18"	6"	2"	1"
Ø14 & Ø16	18"	6"	3"	1"
Ø18 & Ø22	18"	7"	3"	2"
Ø24	18"	8"	3"	2"
Ø25 & Ø28	18"	8"	4"	2"
Ø30	18"	9"	4"	2"
Ø32 & Ø34	18"	9"	4"	3"
Ø36 to Ø40	18"	10"	5"	3"
Ø42 & Ø44	18"	11"	5"	3"
Ø46	18"	11"	6"	4"

LAVAL, QC CANADA NP355 REV. 00

UL LISTED MH61322 377

ACCESSORIES DCL ACCESSOIRES

UL-103 : Factory-Built Chimneys for Residential Type and Building Heating Appliances.
 UL-2561: 1400°F Factory-Built Chimneys, For Venting Liquid, Gas-Fired Appliance, MAXIMUM 60" WATER COLUMN INTERNAL PRESSURE.
 UL-1777: Chimney Liners into NEW or EXISTING Masonry chimneys.
 CAN/ULC-S635, Class 2: Lining System for EXISTING Masonry only. For the venting of Oil and Gas-Fired at 300°C (572°F). UL-1978 & CAN/ULC-S662: Factory Built Grease Duct.
 Install and Use Only in Accordance With DURAVENT INC. Installation and Maintenance Instructions.

UL-103: Cheminées Préfabriquées de type Résidentiel et Appareils de chauffage.
 UL-2561: Cheminées Préfabriquées 1400°F (760°C). Liquide et Gaz.
 ULC-S635, Classe 2: Chemisage pour les Ouvrages de Maçonnerie EXISTANTES ou les Cheminées et les Conduits d'Évacuation Préfabriqués.
 Évacuation d'appareils alimentés au gaz ou au mazout dont la température des produits de combustion n'excède normalement pas 300°C (572°F).
 UL-1978 & CAN/ULC-S662: Conduits de Graisse Préfabriqués.

TOUJOURS SUIVRE LE MANUEL D'INSTALLATION ET MAINTENANCE DE DURAVENT INC.

ATTENTION: NE PAS ENFERMER DANS UNE ENCEINTE COMBUSTIBLE. RISQUE D'INCENDIE.

LAVAL, QC CANADA NP364 REV. 00

DCL MODEL - Diameter Ø5" to Ø36" Diamètre - MODÈLE DCL

UL-103 : Factory-Built Chimneys for Residential Type and Building Heating Appliances.
 UL-2561: 1400°F Factory-Built Chimneys.
 For Venting Liquid, Gas-Fired Appliance.
 CAUTION: DO NOT ENCLOSE WITH COMBUSTIBLE MATERIALS. RISK OF FIRE.
 USA only: - Maximum Flue Gas 1000°F (540°C), Minimum Clearance Air Space is 18" to Combustible Material and Building Insulation.
 - Maximum Flue Gas From 1001°F to 1400°F (760°C), Minimum Clearance Air Space 36" to Combustible Material and Building Insulation.
 For Installation Only as Required For Single Wall Metal Chimneys (Smoke Stacks).
 MAXIMUM 60" WATER COLUMN INTERNAL PRESSURE. For Positive Pressure Applications.
 Suitable for Exterior and Interior Installation.

UL-1777: Chimney Liners into NEW (US only) or EXISTING Masonry chimneys.
 THIS LINER IS TO BE INSTALLED IN A MASONRY CHIMNEY WHERE THERE IS A MINIMUM CLEARANCE OF 1" OF AIR SPACE BETWEEN COMBUSTIBLE MATERIALS AND THE MASONRY CHIMNEY EXTERIOR.
 For Use Only With Appliances Which Burn Natural Gas (Category 1), Propane or Oil Fuel (Type-L), In which maximum continuous flue-gas outlet temperature do not exceed 570°F (299°C).
 CAN/ULC-S635, Class 2: Lining System for EXISTING Masonry or Factory-Built Chimneys and Vents.
 For the venting of Oil and Gas-Fired appliances where the temperature of the flue-gas products does not normally exceed 300°C (572°F).
 WARNING: Install only in existing chimneys. For use only with appliances which burn oil or gas only. Lining systems must be installed in accordance with Manufacturer's Installation Instructions.

UL-1978 & CAN/ULC-S662: Factory Built Grease Duct
 When the grease duct passes through a partition or wall, maintain 18 inch air space to combustible materials.
 Install and Use Only in Accordance With DURAVENT INC. Installation and Maintenance Instructions.

UL-103 : Cheminées Préfabriquées de type Résidentiel et Appareils de chauffage.
 UL-2561: Cheminées Préfabriquées 1400°F (760°C).
 Pour Évacuer Combustible Liquide et Gaz.
 ATTENTION: NE PAS ENFERMER DANS UNE ENCEINTE COMBUSTIBLE. RISQUE D'INCENDIE.
 E-U, Seulement: - Température Maximale Interne à 1000°F (540°C); Dégage (Espace d'Air) Minimale de 18" Aux Matières Combustibles et aux Isolants de la Bâtisse.
 - Température Maximale Interne de 1001°F à 1400°F (760°C); Dégage (Espace d'Air) Minimale de 36" aux Matières Combustibles et aux Isolants du Bâtiment.
 Installer Uniquement tel que Requis pour les Cheminées Simple Paroi en Métal (Cheminées de fumée).
 PRESSION POSITIVE INTERNE MAXIMALE DE 60" DE COLONNE D'EAU Pour Application Pression Positive Utilisable à l'extérieur et à l'intérieur.

UL-1777: Chemisage pour Cheminées de Maçonnerie NEUVES (E-U, SEULEMENT) ou EXISTANTES. CE CONDUIT DE TUBAGE DOIT ÊTRE INSTALLÉ DANS UNE CHEMINÉE DE MAÇONNERIE OÙ IL Y A UN DÉGAGEMENT MINIMALE DE 1" D'AIR ENTRE LES MATÉRIELS COMBUSTIBLES ET L'EXTÉRIEUR DE LA CHEMINÉE DE MAÇONNERIE.
 Évacuation pour les appareils alimentés au Gaz Naturel (Catégorie 1), au Propane ou au Mazout (Type L) dont la température des produits de combustion n'excède normalement pas 570°F (299°C).
 CAN/ULC-S635, Classe 2: Chemisage pour les Ouvrages de Maçonnerie EXISTANTES ou les Cheminées et les Conduits d'Évacuation Préfabriqués.
 Évacuation pour les appareils alimentés au Gaz, au Mazout ou dont la température des produits de combustion n'excède normalement pas 300°C (572°F).
 AVERTISSEMENT: Installer seulement dans les cheminées existantes. Aux fins d'utilisation avec des appareils alimentés au gaz ou au mazout seulement. Les systèmes de chemisage doivent être installés conformément aux directives d'installation du fabricant.

UL-1978 & CAN/ULC-S662: Conduits de Graisse Préfabriqués.
 Lorsque le conduit de graisse passe à travers un cloison ou un mur, maintenir un dégage d'air minimale de 18" d'air avec les matériaux combustibles.
 Toujours Suivre le Manuel d'Installation et Maintenance de DURAVENT INC.

UP HAUT
 FLOW DIRECTION ECOULEMENT

DURAVENT INC. LAVAL, QC, CANADA NP338 REV. 04

SECTION B - GENERAL INFORMATION

PART NUMBERS

These instructions identify major model parts by name and part number.

MATERIAL CODE DESIGNATION
 B = Type 316 Stainless Steel
 C = Type 304 Stainless Steel
 E = Alu-Zinc Coating (Galvalume)

Example:

DIS1 36" length with inside diameter 14" made of SS inner liner and SS 304 outer casing; Code = DIS1-14L36BC.

DIS1- 14 L36 BC
 Model Dia. Part Material

DAS1 30" elbow with inside diameter 22" made of 304 inner flue and galvalume outer casing; Code = DAS1-22E30CE.

DAS1- 22 E30 CE
 Model Dia. Part Material

DCL wall support for 8" diameter grease duct made of galvalume; Code = DCL8WSE:

DCL 8 WS E
 Model Dia Part Material

Use only factory-supplied components. Failure to do so will void the certification and the warranty of the chimney system.

EFFECTIVE LENGTH AND THICKNESS

The effective length is the length of the part when it is assembled.

Effective length	Thickness for Ø5 to Ø36
L36..... 36 1/8"	Inner Wall:0.035"
L24..... 24 1/8"	Outer Wall:0.024"
L18..... 17 5/8"	
L12..... 11 5/8"	

CLEARANCE TO COMBUSTIBLE

Model DAS1, DIS1, DIS2, DIS4 and DIS3Z can be used for either combustible or non-combustible surroundings. When installed in an open room where enclosure is not required, the chimney may be located at a minimum clearance to adjacent combustible walls in accordance with Table 1 and Table 2. The chimney may be located in corners formed by two combustible constructions (walls, floor, ceiling, supports, etc.).

NOTE: The clearance distance with the wall is the distance between the wall and the Inner V-Band (for Model DCL) or the Outer Band BSE (for Model DAS1, DIS1, DIS2, DIS4 and DIS3Z). See Figure 1 for the clearance distance.

For fire resistive noncombustible enclosure construction, maintain clearance as required for installation access for inspection or per local code. In buildings more than one story in height and in one-story buildings where the roof-ceiling assembly is required to have a fire resistance rating, the duct must be enclosed in a continuous enclosure from the lowest fire-rated ceiling or floor, through any concealed spaces, to or through the roof to maintain the integrity of the fire separations required by the applicable building code provisions. If the building is less than 4 stories in height, the enclosure shall have a fire resistance rating of not less than 1 hour. If the building is 4 stories or more in height, the enclosure shall have a fire resistance rating not less than 2 hours.

Duravent Models DCL, DAS1, DIS1, DIS2, DIS4 and DIS3Z chimneys may penetrate a combustible floor, wall, or roof using the appropriate parts and openings sizes. See section D "Roof & Wall Penetration" for more details.

NOTE: Model DIS3Z is equivalent to a 2-Hr fire rated grease duct enclosure system.

NOTE: Do not completely enclose the chimney with combustible materials.

In the case of a fire rated enclosure made of non-combustible or limited combustible construction, the minimum clearance for Model DCL is 6" or as required by local code.

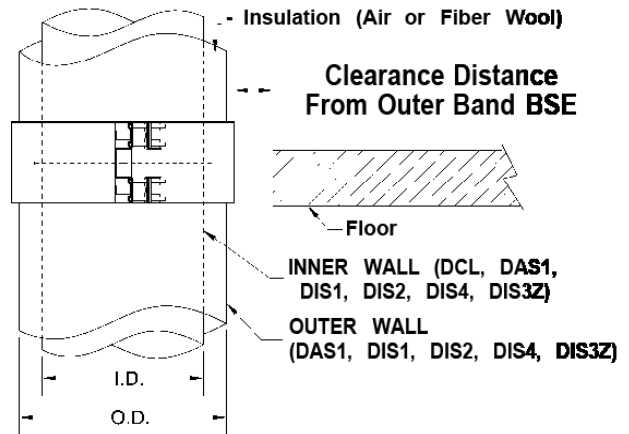

Figure 1 - Detail of Clearance Distance

Building Heating Appliance & 1400°F Chimney:

TABLE 1 - PRESSURE STACK Clearances to Combustibles			
Minimum Air Space CLEARANCE to Unenclosed Combustible material and building insulation for 1400°F (760°C) continuous temperature.			
Duct Model	Flue Diameter Ø (in)	Clearance to Combustible (in)	Clearance to Non-Combustible (in)
DCL (1000°F)	Ø5 to Ø36	18	0
DCL (1400°F)	Ø5 to Ø36	36	0
DAS1	Ø5 to Ø6	4	0
	Ø7 to Ø14	5	0
	Ø16 to Ø22	6	0
	Ø24 to Ø30	7	0
	Ø32 to Ø36	8	0
DIS1 (UL 103 Type HT Ø5 to Ø24 only)	Ø5 to Ø6	1	0
	Ø7 to Ø14	2	0
	Ø16 to Ø22	3	0
	Ø24 to Ø30	4	0
DIS2 & DIS4 (UL 103 Type HT Ø5 to Ø24 only)	Ø5 to Ø14	1	0
	Ø16 to Ø30	2	0
	Ø32 to Ø36	3	0

Dimensions are in inches

Grease Duct Application:

TABLE 2 - GREASE DUCT UL-1978 and UL-2221 (DIS3Z only) Clearances to Combustible (Unenclosed Surrounding)			
Minimum Air Space Clearances to Combustible material and Building insulation for 500°F (260°C) continuous temperature grease duct system.			
Duct Model	Flue Diameter Ø (in)	Clearance to Combustible (in)	Clearance to Non-Combustible (in)
DCL	Ø5 to Ø36	18	0
DAS1	Ø5	4	0
	Ø6 to Ø11	5	0
	Ø12 & Ø16	6	0
	Ø18 & Ø22	7	0
	Ø24 & Ø28	8	0
	Ø30 & Ø34	9	0
	Ø36	10	0
DIS1	Ø5 to Ø13	2	0
	Ø14 to Ø24	3	0
	Ø26 to Ø34	4	0
	Ø36	5	0
DIS2 and DIS4	Ø5 to Ø16	1	0
	Ø18 to Ø30	2	0
	Ø32 to Ø36	3	0
DIS3Z (UL-2221)	Ø5 to Ø36	0	0

Dimensions are in inches

NOTE: DIAGRAMS & ILLUSTRATIONS ARE NOT TO SCALE.

OPENING THROUGH CONSTRUCTION

The following tables serves to identify the minimum opening required when installing a chimney through a floor, wall or roof made of combustible material. See Figure 2 and Table 3 & Table 4.

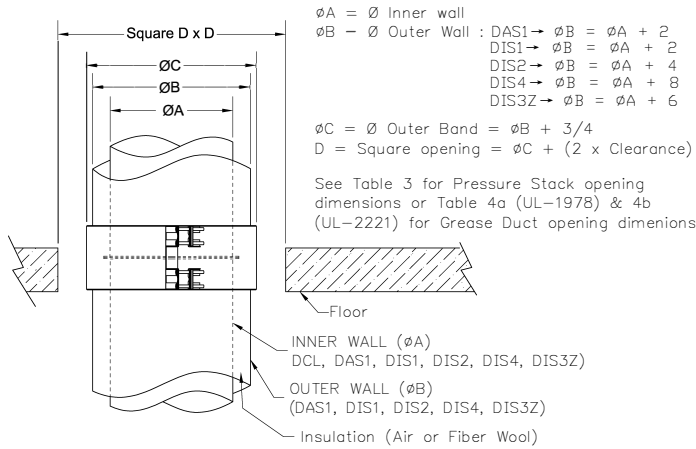

Opening required when installing the Models DuraStack PRO series in Building heating application or Grease Duct (UL-1978 and UL-2221) application through a roof, floor or wall made of combustible materials.

Figure 2 - Opening Through Construction Models DAS1, DIS1, DIS2, DIS4

Building Heating Appliance & 1400° F Chimney:

Stack Model	Flue Diameter ϕ (in)	Combustible Roof / Floor / Wall (in)	Non-Combustible ** Roof / Floor / Wall (in)	
			Installed Stacks (Locking bands installed on Sections)	Uninstalled Stack (No Locking bands installed on Sections)
DCL	$\phi 5$ to $\phi 36$	I.D. + 37 1/4"	I.D. + 2 1/2"	I.D. + 1 1/8"
DAS1	$\phi 5$ to $\phi 6$	I.D. + 10 3/4"	I.D. + 3 1/2"	I.D. + 2 3/4"
	$\phi 7$ to $\phi 14$	I.D. + 12 3/4"		
	$\phi 16$ to $\phi 22$	I.D. + 14 3/4"		
	$\phi 24$ to $\phi 30$	I.D. + 16 3/4"		
DIS1	$\phi 32$ to $\phi 36$	I.D. + 18 3/4"	I.D. + 3 1/2"	I.D. + 2 3/4"
	$\phi 5$ to $\phi 6$	I.D. + 4 3/4"		
	$\phi 7$ to $\phi 14$	I.D. + 6 3/4"		
	$\phi 16$ to $\phi 22$	I.D. + 8 3/4"		
DIS2	$\phi 24$ to $\phi 30$	I.D. + 10 3/4"	I.D. + 5 1/2"	I.D. + 4 3/4"
	$\phi 32$ to $\phi 36$	I.D. + 12 3/4"		
	$\phi 5$ to $\phi 14$	I.D. + 6 3/4"		
	$\phi 16$ to $\phi 30$	I.D. + 8 3/4"		
DIS4	$\phi 32$ to $\phi 36$	I.D. + 10 3/4"	I.D. + 9 1/2"	I.D. + 8 3/4"
	$\phi 5$ to $\phi 14$	I.D. + 10 3/4"		
	$\phi 16$ to $\phi 30$	I.D. + 12 3/4"		
DIS3Z	$\phi 32$ to $\phi 36$	I.D. + 14 3/4"	I.D. + 7 1/2"	I.D. + 6 3/4"
	$\phi 5$ to $\phi 6$	I.D. + 6 3/4"		

Dimensions are in inches

** Even if the clearance to combustibles is 0" for non-combustible, the opening must be larger due to the design of the product.

Duct Model	Flue Diameter ϕ (in)	Combustible Roof / Floor / Wall (in)	NON-Combustible** and NOT Fire-Rated Roof / Floor / Wall (in)	
			Installed Stacks (Locking bands installed on Sections)	Uninstalled Stack (No Locking bands installed on Sections)
DCL	$\phi 5$ to $\phi 36$	I.D. + 37 1/4"	I.D. + 2 1/2"	I.D. + 1 1/8"
DAS1	$\phi 5$	I.D. + 10 3/4"	I.D. + 3 1/2"	I.D. + 2 3/4"
	$\phi 6$ to $\phi 11$	I.D. + 12 3/4"		
	$\phi 12$ & $\phi 16$	I.D. + 14 3/4"		
	$\phi 18$ & $\phi 22$	I.D. + 16 3/4"		
	$\phi 24$ & $\phi 28$	I.D. + 18 3/4"		
	$\phi 30$ & $\phi 34$	I.D. + 20 3/4"		
DIS1	$\phi 36$	I.D. + 22 3/4"	I.D. + 3 1/2"	I.D. + 2 3/4"
	$\phi 5$ to $\phi 13$	I.D. + 6 3/4"		
	$\phi 14$ to $\phi 24$	I.D. + 8 3/4"		
	$\phi 26$ to $\phi 34$	I.D. + 10 3/4"		
DIS2	$\phi 36$	I.D. + 12 3/4"	I.D. + 5 1/2"	I.D. + 4 3/4"
	$\phi 5$ to $\phi 16$	I.D. + 6 3/4"		
	$\phi 18$ to $\phi 30$	I.D. + 8 3/4"		
DIS4	$\phi 32$ to $\phi 36$	I.D. + 10 3/4"	I.D. + 9 1/2"	I.D. + 8 3/4"
	$\phi 5$ to $\phi 16$	I.D. + 10 3/4"		
	$\phi 18$ to $\phi 30$	I.D. + 12 3/4"		
DIS3Z	$\phi 32$ to $\phi 36$	I.D. + 14 3/4"	I.D. + 7 1/2"	I.D. + 6 3/4"
	$\phi 5$ to $\phi 6$	I.D. + 6 3/4"		

Dimensions are in inches

** Even if the clearance to combustibles is 0" for non-combustible, the opening must be larger due to the design of the product.

Duct Model	Flue Diameter ϕ (in)	Through 2hr Fire-Rated or less Floor, Wall or Roof (in)
DIS3Z	$\phi 5$ to $\phi 36$	I.D. + 8

Dimensions are in inches

NOTE: Make sure the joint of two sections is not inside the hole

SYSTEM SIZING

Complete system sizing and capacity information may be obtained from the "Chimney, Gas Vent, and Fireplace Systems" chapter of the ASHRAE Handbook (go to www.ashrae.org for more information). In spite of these general sizing guidelines, it is most important that the heating appliance, engine or turbine manufacturer's installation instructions are followed. Not following the equipment manufacturer's instructions may result in inadequate chimney performance and/or a violation of the equipment manufacturer's installation requirements.

SLOPE FOR GREASE DUCT APPLICATION

Nationally recognized codes require horizontal grease ducts to slope at a minimum of 1/4 unit vertical in 12 units of horizontal toward the hood or grease reservoir. In addition, where horizontal ducts exceed 75 feet in length, the slope shall not be less than one unit vertical in 12 units horizontal. This general rule for duct slope is prescribed for grease ducts that are not listed and/or evaluated by an accredited third body testing agency. For factory-built grease ducts that are listed to UL1978 and have been further tested and/or analyzed to provide equivalent or better flow characteristics as compared to field-installed grease ducts, reduced duct slope is permitted per the factory-built grease duct listing.

For Duravent factory-built grease ducts listed to UL1978, install at a duct slope not less than 1/16 unit vertical slope in 12 units of horizontal toward the hood or toward the grease reservoir. Where Duravent grease ducts listed to UL1978 exceed 75 feet in length, the slope shall not be less than 3/16" unit vertical slope in 12 units horizontal. This minimum slope is a result of tests and/or analysis performed by Underwriters Laboratories, where factory-built grease duct was compared to rectangular field-applied grease duct for performance of flow characteristics. Consult with AHJ for acceptance of this alternate method.

FREIGHT DAMAGE

Each component should be checked for freight damage when it is unloaded at the site. For damaged components contact the shipping company as soon as possible to file a claim.

PROPER STORAGE

All chimney components should be stored in a dry place until installed. Sealant shall be stored in location where it will not freeze.

PRODUCT WEIGHTS

The average weight of the duct, per foot of length, can be estimated using the following formula:

DCL: 0.40 x diameter in inches = lbs per foot
 DAS1: 0.79 x diameter in inches = lbs per foot
 DIS1: 0.93 x diameter in inches = lbs per foot
 DIS2: 1.09 x diameter in inches = lbs per foot
 DIS4: 1.44 x diameter in inches = lbs per foot
 DIS3Z: 1.52 x diameter in inches = lbs per foot

Chimney design should provide adequate support to ensure components are not overloaded.

THERMAL EXPANSION CALCULATIONS

Thermal expansion under normal operating temperatures can fatigue welds and joints causing leakage. To calculate the thermal expansion, use the following formula:

$$[\text{Length (ft)} / 100] \times [\text{Temperature Rise degrees F} / 100]$$

Example: $[50' / 100] \times [75^\circ\text{F} / 100] = 0.375''$ Expansion

If the computed expansions between the fixed points is greater than 0.375" Duravent recommends an adjustable or bellow length be installed.

SUPPORT METHODS AND HEIGHT LIMITS

- Several support and guiding methods are used to anchor a chimney against upward, downward and angular displacement.
- These supports and guides used with thermal expansion devices, prevent bending stresses on the chimney elbows and joints.
- Supports and guiding methods and installation are described in SECTION E-SUPPORTS. Certain limitations apply for proper installation of supports and guides. See Tables 5, 6, 7 and Figures 3 and 4.
- It is recommended to apply an exterior grade high heat paint to any plate supports, full/half angle rings, wall supports/guides, aluminized outer maximum corrosion protection against the elements. (Ex: Rustoleum V200 series High Heat Industrial Aerosol).

NOTE: All the weight of the section must be supported by the inner flue. Never support any chimney pipe from the outer casing.

Parts	Flue Diameter Ø (in)	Height (ft)					
		DCL	DAS1	DIS1	DIS2	DIS4	DIS3Z
Anchor Plate (AP)	Ø5 to Ø22	264	133	114	97	73	70
	Ø24 to Ø36	161	82	70	59	45	42
Anchor Plate with Length (APL)	Ø5 to Ø22	281	142	121	103	78	74
	Ø24 to Ø36	172	87	74	63	48	45
Base supported Tee (T90 or T45)	Ø5 to Ø22	102	52	44	37	28	27
	Ø24 to Ø36	63	32	27	23	17	16
Wall Support (WSHD)	Ø5 to Ø22	105	53	45	39	29	28
	Ø24 to Ø36	64	32	28	24	18	17

WARNING: Do not attached any supports to combustible constructions.

Dimensions are in inches (diameter) and feet (distance)

Parts	Flue Diameter (in)	Max Height (ft)
Guy Support (GS)	5	231
	6	193
	7	165
	8	145
	9	128
	10	116
	11	105
	12	96
	13	89
	14	83
	16	72
	18	64
	20	58
	22	53
	24	48
	26	44
	28	41
	30	39
32	36	
34	34	
36	32	

Model	DCL		DAS1 / DIS1		DIS2		DIS4		DIS3Z	
	Height (ft)		Height (ft)		Height (ft)		Height (ft)		Height (ft)	
Flue Diameter Ø (in)	MVS*	H**	MVS*	H**	MVS*	H**	MVS*	H**	MVS*	H**
5	20'	8'6"	20'	7'3"	20'	6'6"	20'	6'	20'	6'
6	20'	9'6"	20'	8'3"	20'	7'6"	20'	6'9"	20'	6'9"
7	20'	10'	20'	8'9"	20'	8'3"	20'	7'	20'	7'
8	20'	11'	20'	9'	20'	8'6"	20'	7'3"	20'	7'3"
9	20'	11'6"	20'	9'3"	20'	8'9"	20'	7'6"	20'	7'6"
10	20'	12'	20'	9'6"	20'	9'	20'	7'9"	20'	7'9"
11	20'	12'6"	20'	9'9"	20'	9'3"	20'	8'	20'	8'
12	20'	13'	20'	10'	20'	9'6"	20'	8'3"	20'	8'3"
13	20'	13'6"	20'	10'3"	20'	9'9"	20'	8'6"	20'	8'6"
14	20'	14'	20'	10'6"	20'	10'	20'	9'	20'	9'
16	20'	14'6"	20'	11'	20'	10'6"	20'	9'6"	20'	9'6"
18	20'	15'	20'	11'6"	20'	11'	20'	10'	20'	10'
20	20'	15'	20'	12'	20'	11'6"	20'	10'9"	20'	10'9"
22	20'	15'	20'	12'3"	20'	11'9"	20'	11'	20'	11'
24	20'	15'	20'	12'9"	20'	12'3"	20'	11'6"	20'	11'6"
26	20'	15'	20'	13'	20'	12'6"	20'	12'	20'	12'
28	20'	15'	20'	13'6"	20'	13'	20'	12'3"	20'	12'3"
30	20'	15'	20'	13'9"	20'	13'6"	20'	12'9"	20'	12'9"
32	20'	15'	20'	14'3"	20'	13'9"	20'	13'3"	20'	13'3"
34	20'	15'	20'	14'6"	20'	14'3"	20'	13'6"	20'	13'6"
36	20'	15'	20'	15'	20'	14'6"	20'	13'9"	20'	13'9"

* MVS = Maximum Vertical Spacing between two guides or support and guide in a vertical position.
 ** H = Maximum Freestanding Height above the roof. This limited height is due to wind loads.

Dimensions are in inches (diameter) and feet (distance)

TABLE 7 - Maximum Horizontal Spacing between each Guides/Supports							
Product	Flue Diameter Ø (in)	Distance (ft)					
		DCL	DAS1	DIS1	DIS2	DIS4	DIS3Z
Half Angle Ring (HAR) Full Angle Ring (FAR) / Anchor Support (AP) / Anchor plate with Length (APL) / Heavy Duty Wall Guide (HDWG)	Ø5 to Ø12	23	23	19	16	12	12
	Ø14 to Ø24	19	19	16	14	10	10
	Ø26 to Ø36	15	15	13	11	8	8

NOTE: The Half Angle Ring (HAR) and Full Angle Ring (FAR) used in horizontal installation must be installed with threaded rod having a minimum of Ø1/2" or with structural steel provided by others.

Dimensions are in inches (diameter) and feet (distance)

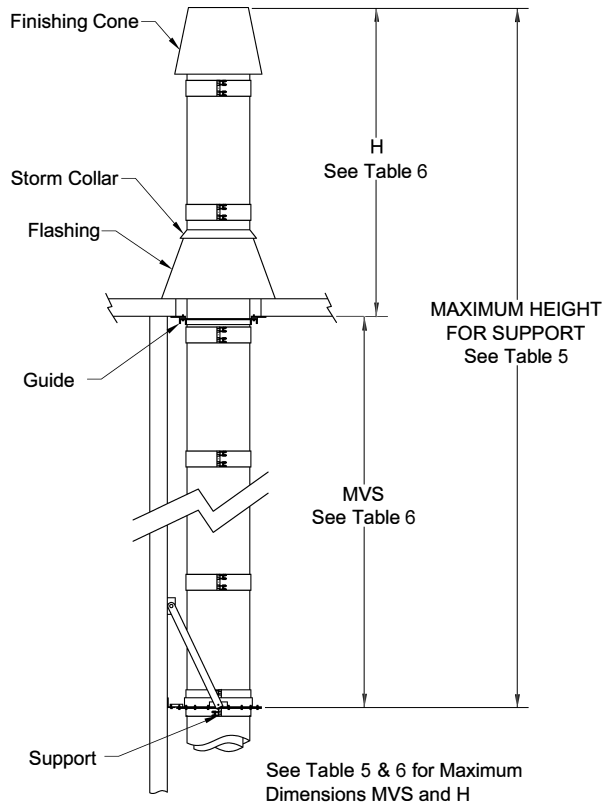

Figure 4 - Maximum freestanding height

EXTERIOR CORROSION PROTECTION

It is recommended to apply an exterior grade high heat paint to any plate supports, full/half angle rings, wall supports/guides, aluminized outer walls corrosion protection against the elements. (Ex. Rustoleum V200 series High Heat Industrial Aerosol).

SEISMIC REQUIREMENTS

In certain areas of the country, local codes contain requirements to address seismic risks. Seismic requirements for chimneys and grease ducts usually include specifications for additional "sway bars" / bracing, or similar devices in order to help stabilize the system in the event of an earthquake.

Specific guidelines (including spacing, location, size and method of attachment of bracing / sway bars or other devices) for addressing seismic requirements vary depending upon the adopted code, seismic zone, duct size, location in building, etc. and are not within the scope of these installation instructions.

Consult with a design professional in order to determine compliance options for these potentially complex requirements when this product is to be installed in a building where these additional requirements apply.

The support methods described in these instructions have been proven adequate (via UL certification) for locations where there are no additional seismic zone requirements. In order to address additional seismic requirements they may be further supplemented with a variety of generic sway bars or braces that attach to or around the outer wall of the grease duct system. Full Angle Rings (FAR) and Half Angle Rings (HAR) may be included as components of such supplemental bracing.

PRODUCT INSPECTION

Chimney components are shipped on individually marked skids. Compare the labeled skids to the packing list to ensure all components of the chimney system have been shipped. For missing components contact Duravent's Customer Service department at 800-667-3387 (Canada) or 800-361-4909 (USA).

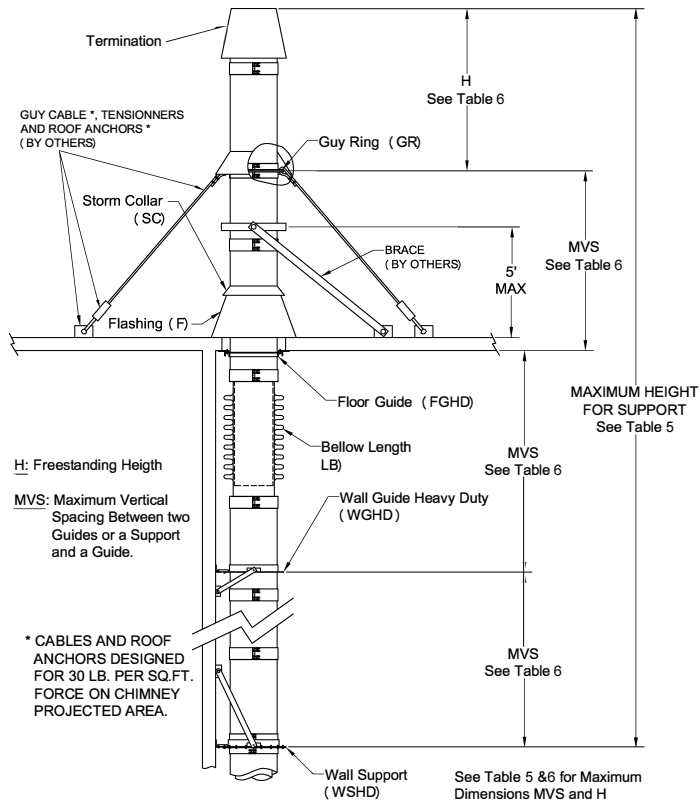

Figure 3 - Maximum Supported Height

GUYING AND BRACING

1. Proper guying and bracing is essential for part of the chimney that extends above the roof or parapet wall. The chimney at this point is subject to wind conditions and needs special attention for proper stabilization. See Figure 3.
2. If the chimney above the roof does not exceed dimension H, no special guying or bracing is required. However, to protect the flashing from lateral movement, a guide must be installed at the roof level. See Figure 4.
3. For chimney height above the roof that needs guying or bracing, a support, a small length and an expansion length must be installed near the roof level to absorb the thermal expansion and minimize this effect on the guy wires or brace.
4. When using guy wire, the cable must be slightly slack or loose to allow thermal expansion.
5. When using rigid bracing, the maximum vertical height between supports must be reduced to 5' to compensate thermal expansion.

SECTION C - PIPE & FITTING JOINT ASSEMBLY

The ends of each inner pipe are made of flanges. All the joints between sections are a flange-to-flange connection of the inner pipe.

CAUTION: SHARP SHEET METAL, RISK OF CUTS WITH SLEEVES AND SECTIONS.

SPECIAL FEATURE

All sections have an unattached alignment sleeve (See figure 5).

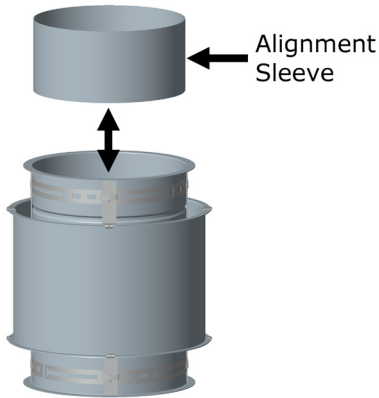

Figure 5 - Feature of the alignment part

The alignment sleeve facilitates centering of adjacent sections and provides a backing for the sealant applied to the flange keeping the sealant in the intended location. Typically, it is inserted in the downstream end but may be removed. Although not required, it aids in easier assembly, better sealing and adds strength to the section joint.



Figure 6 - Joint Assembly Step 1

JOINT ASSEMBLY

STEP 1

Fill the channel of the inner V-Band (BSI) with the right Sealant, depending on flue gas temperature (refer to SEALANT USAGE section for proper sealant selection) and install below flange of first pipe section.

NOTE: Sealant is supplied by Duravent and individual tubes are marked S-2000 or S-650. See TABLE 6 for number of tubes per joint.

CAUTION: THE USE OF ANY OTHER SEALANT IS NOT RECOMMENDED, MAY VOID CERTIFICATION AND MAY IMPAIR THE SEALING EFFECTIVENESS.

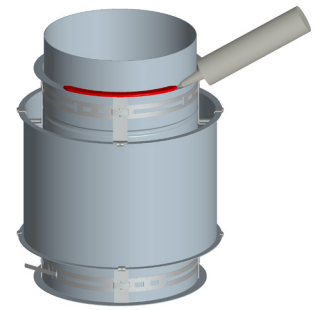

Figure 7 - Joint Assembly Step 2

STEP 2

Apply a small continuous bead of S-2000 or S-650 sealant approximately 3/16" wide to one of the flanges to be joined (Refer to sealant usage for selection).

STEP 3

Join the two flanged ends of the duct section together and rotate slightly to ensure complete coverage of sealant on flanges.

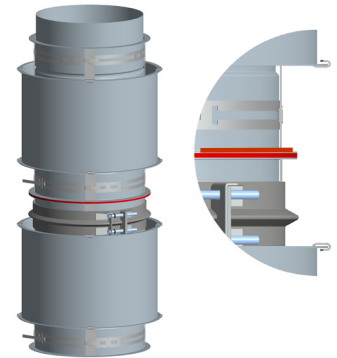

Figure 8 - Joint Assembly Step 3

STEP 4

Install the V-Band around the flanges making sure the flanges are located within the V-Clamp.

NOTE: Do not locate V-Band hardware at the bottom side of horizontal duct joints.

NOTE: Light tapping with a hammer all around the band while tightening bolts helps align and pull flanges together.

NOTE: Screws can easily be damaged if too much torque is used. Tighten gently.



Figure 9 - Joint Assembly Step 4

STEP 5 (DIS1, DIS2, DIS4, and DIS3Z)

Install the supplied insulation strips between the sections to ensure that all air gaps are filled. Be sure that insulation is tightly packed and completely fills the void between flue and closure band when assembled.

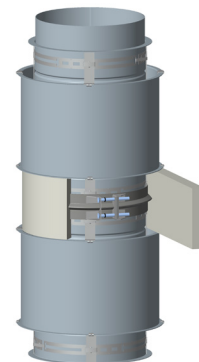

Figure 10 - Joint Assembly Step 5

STEP 6 (Models DAS1, DIS1, DIS2, DIS4, and DIS3Z only)

Secure the Outer Casing with the Outer Band (BSE).
Joint installation is now complete.

NOTE: Seal the BSE band with
S-375 sealant if exposed to weather.

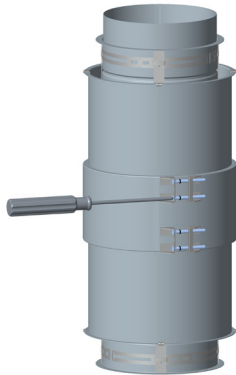

Figure 11 - Joint Assembly Step 6

CAUTION:

- THE OUTER BAND (BSE) IS DESIGNED TO SLIDE ON THE OUTER WALL. DO NOT ATTACH BY SCREWS INTO THE OUTER CASING.

- DO NOT ALLOW SCREWS TO PENETRATE THE INNER PIPE. THIS CAN CAUSE CORROSION, GAS LEAKAGE OR EXPANSION FAILURE.

- NEVER USE SCREWS THROUGH THE OUTER JACKET OF A BELLOW LENGTH

SEALANT USAGE

1. Part No. S-2000: a high temperature pre-mixed sealant for flue gas temperature up to 2000°F, (High temperature heating system or exhaust generator). S-2000 IS WATER SOLUBLE AND SHOULD NOT BE USED WHERE EXPOSED TO WEATHER.

2. Part No. S-650 (Permatex® Red High Temp Silicone) is red and is one of our UL approved sealants for temperatures up to 650°F, (Low temperature heating system or grease duct). Can also be used for weathering/sealing on outdoor seams & Channel Bands where necessary.

3. Part No. S-375 (Nuflex 302 General Purpose) is a low temperature grey silicone (450°F) only for weathering/sealing on outdoor seams & Outer Band BSE where necessary.

TABLE 10 - Expected number of Tubes per Joint Assembly (for S-2000, S-650 or S-375)	
Flue Diameter (in)	Number of tube per Joint
5 to 10	1/5
11 to 16	1/4
18 to 22	1/3
24 to 28	1/2
30 to 36	2/3
32 to 36	3/4

SECTION D - COMPONENTS

EXPANSION JOINT, ODD LENGTH AND HIGH PRESSURE SYSTEM

Three different parts can be used when a system has the following situation:

- Thermal Expansion and Positive Pressure System = Bellow Length (LB)
- Positive pressure and odd length = Variable Length (LV)
- Odd Length and Thermal Expansion = Adjustable Length (LA).

See Figure 52 and 53 in Section E for typical installation of LA, LV and LB.

THERMAL EXPANSION

The inner pipe of Models DCL, DAS1, DIS1, DIS2, DIS4 and DIS3Z is load bearing and its thermal expansion is the same as that of a continuous pipe. A simplified rule for exhaust pipe expansion estimation is that the axial growth will be approx. 1" per 100' of pipe length for each 100°F the flue gas temperature is above the surrounding air temperature. See THERMAL EXPANSION CALCULATIONS in SECTION B

When assembled in any orientation, the amount of thermal expansion of the inner pipe is directly dependent on the inner wall temperature and the length of pipe between fixed points. Good installation practice requires that expansion greater than 1/4 inch will be compensated for using a Bellows Joint or Adjustable Length, depending on the maximum pressure encountered.

The flanged inner piping joints have negligible flexing capacity, and in addition, tees and elbows are not designed to withstand bending moment forces. Because the amount of outer casing axial movement is the same as inner casing movement, the outer jackets of piping must slide to avoid excessive forces on tees, elbows or fixed points. To accommodate outer casing movements, external guides along walls at floors, or in lateral breechings, must allow for movement of pipe.

CAUTION: When a joint of assembly is just below a Guide Support (WGHD), a minimum space between the top of the outer Band (BSE) and the Guide must be added. This distance must be at least the value of the Thermal expansion calculated.

NOTE: When re-supporting a high rise exhaust system, Adjustable Lengths or Bellows Joints must be used just below every support above the first to compensate for thermal expansion. For engine and turbine exhaust systems requiring pressures to 60 inches of water column, or where the construction must be absolutely gas tight, all welded Bellows Joints are recommended for expansion and vibrational movements of the exhaust piping. Out-of-doors construction or low pressure systems, such as boilers (to 1 inches of water column), can effectively use the Adjustable Length.

Spacing of guides and supports, when a thermal expansion part is used, should be not greater than specified in Section B. Proper guiding and support of expansion parts often requires closer spacing.

Flue Diameter Ø (in)	Bellow Outside Diameter	Bellows number convolution	Material thickness (in)	nb of ply	Axial Spring Rate	Axial Compression (in)
5	6 1/4	14	0.011	2	124	3
6	7 1/4	14	0.011	2	139	3
7	8 3/8	14	0.011	2	151	3
8	9 3/8	12	0.011	2	162	3
9	10 3/8	12	0.011	2	173	3
10	11 3/8	12	0.011	2	184	3
11	12 3/8	12	0.011	2	197	3
12	13 3/8	12	0.011	2	210	3
13	15	8	0.011	2	139	3
14	16	8	0.011	2	149	3
16	18	8	0.011	2	159	3
18	20	8	0.011	2	169	3
20	22	8	0.011	2	181	3
22	24	8	0.011	2	193	3
24	26	8	0.011	2	205	3
26	28	8	0.011	2	216	3
28	30	8	0.011	2	229	3
30	32	8	0.011	2	242	3
32	34	8	0.011	2	255	3
34	36	8	0.011	2	268	3
36	38	8	0.011	2	281	3

Dimensions are in inches (diameter) and pound/inch (Axial Spring Rate)

NOTE: DIAGRAMS & ILLUSTRATIONS ARE NOT TO SCALE.

BELLOWS LENGTH (LB): Thermal Expansion and Positive Pressure

For exhaust pressure up to 60 inches of water column, Bellows are recommended for expansion and vibrational movements of the piping. See Figure 12 for an illustration of a Bellows.

Figure 53 in SECTION E illustrates the use of Bellows in a typical installation. The use of the Lined Bellows Joints is shown to compensate for the axial expansion of the long horizontal run.

The Bellows has a 0.035" thick or heavier straight stainless steel liner to protect the thinner Spring material from heat and flow effects. It is used anywhere in a system for axial and vibrational movements only and must be accurately supported and guided. This part has limited lateral movement (1/8" max.) and lateral offsets and parallel misalignments should be eliminated. The purpose of the liner is to minimize contact, smooth flow, control erosion and eliminate resonance caused by exhaust gases passing through the bellows.

The Bellows requires careful placement of piping guides to avoid interference on thermal expansion. Bellows should not be installed with any compression, but at its full uncompressed length in ambient state.

The joint assembly of the Bellow Length is like the standard sections. See SECTION C for details of Joint Assembly.

The system operating pressure of 60 inches water column (2.08 psi) is based on the estimated capability of ceramic sealed V-Band (BSI) joints. The actual pressure limit of the welded bellows will be 10 psi for 5 to 36 diameter at 1000°F.

HORIZONTAL INSTALLATION OF BELLOWS or ADJUSTABLE LENGTHS

Horizontal or sloped installations of Bellows or Adjustable Lengths use the same parts, assembled in the same relationship, as a vertical assembly. These expansion joints, when required may be placed anywhere between two fixed points of horizontal or sloped installation as long as they are properly guided, properly supported; and for sloped installations in particular, as long as bottoming out is prevented.

VERTICAL INSTALLATION OF BELLOWS or ADJUSTABLE LENGTHS

When a Bellows Joint or an Adjustable Length is installed in a vertical position between two fixed points, such as between a AP, APL or WSHD, it should be installed immediately below or one pipe length below the higher support. To assure proper axial alignment, guides must be installed at the pipe section below the bellows or adjustable length (see Figure 52 and 53 in SECTION E). This combination of parts will assure proper movement of bellows and adjustable lengths and thus relieve loads due to thermal expansion. It is desirable to install bellows and adjustable lengths near the top of a vertical section to ensure that they do not bottom out during installation and thus become ineffective at relieving thermal expansion loads. This arrangement of parts will also resist wind loads on installations which run up building exterior walls.

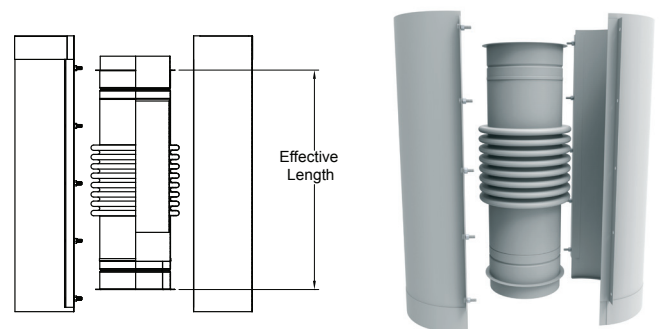

Figure 12 - Bellow Length

ADJUSTABLE LENGTH (LA)*: Thermal Expansion and Odd lengths

*NOTE: At present July 2018, UL LLC has no safety standard for these devices, so although they are shown in this document and condoned by Duravent and others, UL has not independently investigated.

The LA has two functions. It is used to compensate for thermal expansion and make up odd lengths of duct.

NOTE: The LA is suitable for applications on low positive pressure system with less than 1" W.C. A Bellow Length (LB) must be used on higher pressure systems. In a case there is also an odd distance to fit in a positive pressure system, a Variable Length (LV) can be combined with a LB.

It is shipped with graphite band assembly preassembled on the sliding inner pipe. See Figure 13.

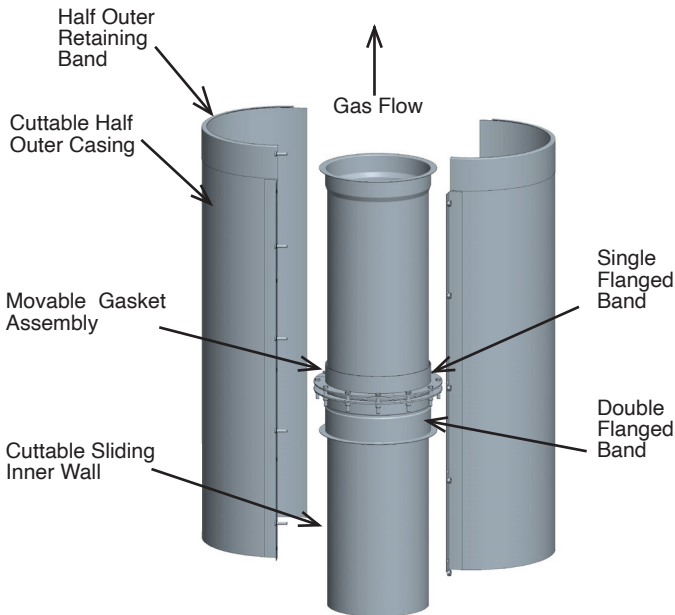

Figure 13 - Adjustable Length

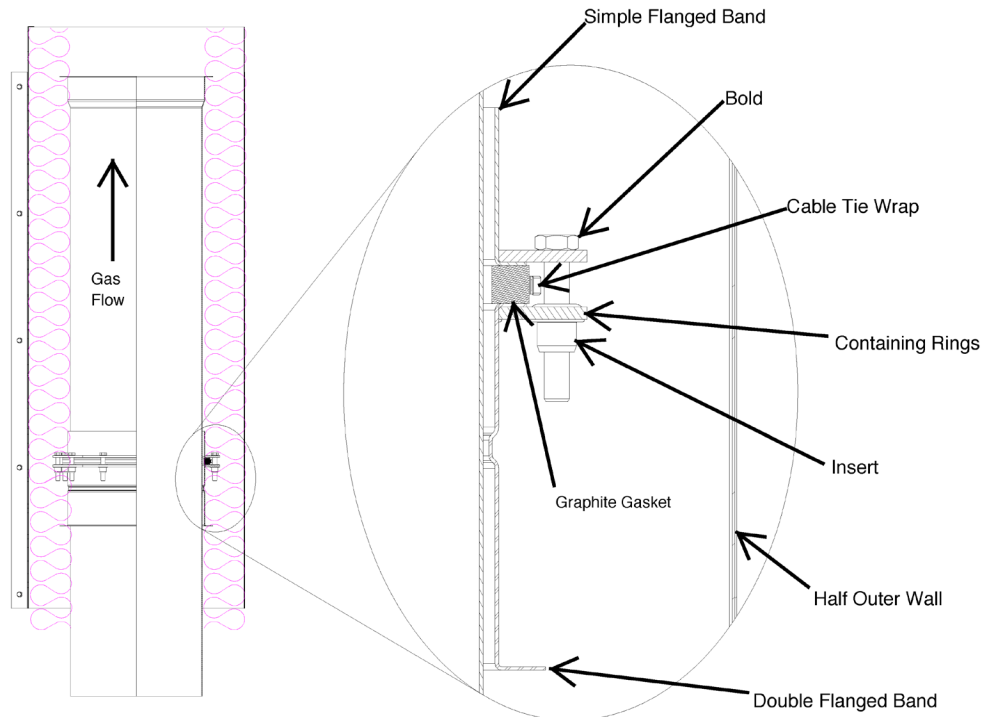

Figure 14 - Detail of Adjustable Length

The whole LA assembly includes:

- A sliding inner wall that fits closely inside a standard pipe section and it is flanged on one side.
- An adjustable gasket assembly, composed of;
 - two containing rings;
 - one compression band (metal Tie Wraps)
 - a graphite packing gasket
 - one double flanged band
 - one other single flanged band
- Insulation band (DIS1, DIS2, DIS4, DIS3Z)
- two half outer casing (DAS1, DIS1, DIS2, DIS4, DIS3Z)

See Figure 14 for details

NOTE: Sealant must be ordered separately. See SEALANT USAGE in SECTION C.

There is also a supplied tool with this assembly. This tool works as a spacer when tighten the bolts of the containing rings on the graphite gasket. See Figure 18.

NOTE: Do not remove this adjustable gasket assembly from the inner pipe. See Figure 14.

The length adjustment from Flange to Flange is from 7 1/4" to 28 3/8". For proper installation, the adjustable length must have adequate overlap and sufficient allowance for thermal expansion.

If the length of the inner wall or the outer casing is too long, it can be cut. However, keep in mind that the minimum overlap for the sliding inner wall into the inlet end section is 8" and the minimum overlap for the outer casing is 1" with the down stream section outer wall (See Figure 15).

NOTE: Installation of an LA joint to fittings, such as elbow and tees, is not recommended. However, if its joint must be joined to one of these fittings, The unflanged end of the tube should always point downward or towards downward slope.

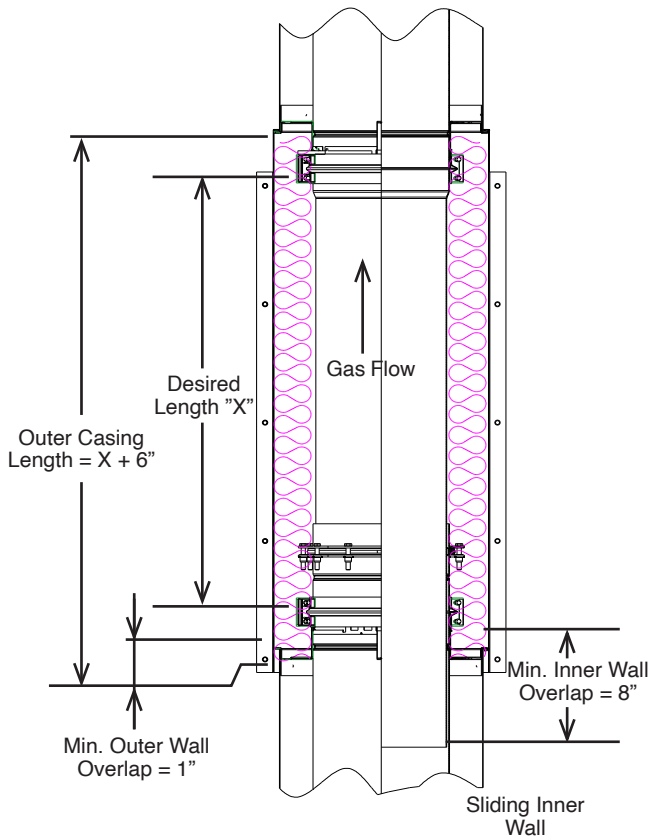

Figure 15 - Detail of Overlap of the Adjustable Length

The expansion length must be added to the minimum length of the LA so it may compensate for abnormal and normal operating conditions.

The amount of expansion is calculated as follows:

$$\text{Expansion} = \text{Length (feet)} / 100 \times \text{Temperature rise (°F)} / 100$$

$$\text{Minimum Length} = \text{Expansion} + 7 \frac{1}{4}''$$

NOTE: It is recommended that the temperature used in the above formula be at least 300°F higher than the expected normal operating temperature.

NOTE: Adjustable Length cannot be used to correct misalignment or to compensate for lateral movement or vibration. It is recommended that the duct on both side of the LA joint is supported or guided to ensure that it will not bind during operation. See Variable and Adjustable Support section for typical applications.

INSTALLATION STEPS FOR THE ADJUSTABLE LENGTH

1. Place the sliding inner liner section (with the graphite band assembly on it) into a standard section of DCL, DIS PRO, DAS PRO and DIS3Z2.

NOTE: If the inner flue is too long, it may be cut to length while respecting the minimum overlap of 8" into the inlet end section duct plus the expansion.

2. Secure the double flanged part of gasket collar assembly to the inlet end section with the inner V-band (BSI). See Figure 16.

NOTE: See JOINT ASSEMBLY section for assembly of the V-Band

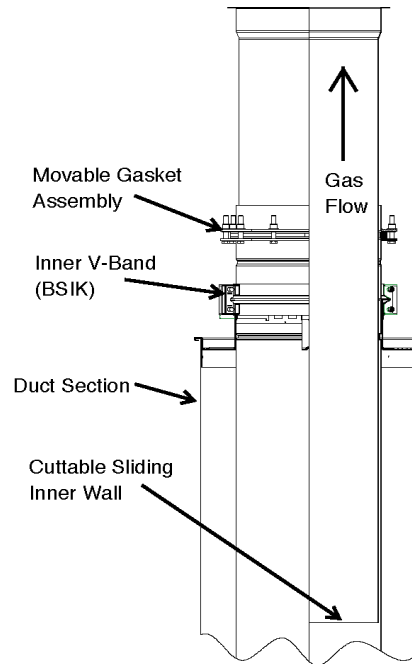

Figure 16 - Installation of Adjustable Length Steps 1 & 2

3. Extend the sliding inner liner to its correct length (up to the outlet end section) and secure it with the V-Band (See JOINT ASSEMBLY section).
4. Strongly tighten the metal tie wrap so that the graphite packing is firmly compressed against the inner flue. See Figure 17.

NOTE: On horizontal run, make sure that the joint of the graphite packing gasket is on the top side of the section.

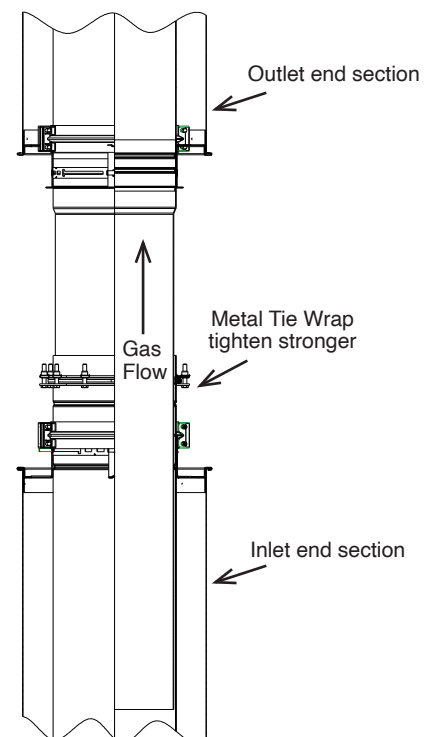

Figure 17 - Installation of Adjustable Length Steps 3 & 4

5. Tighten all the bolts of the containing ring. For each bolt, use the supplied tool as a guide between the two containing rings. See Figure 18.

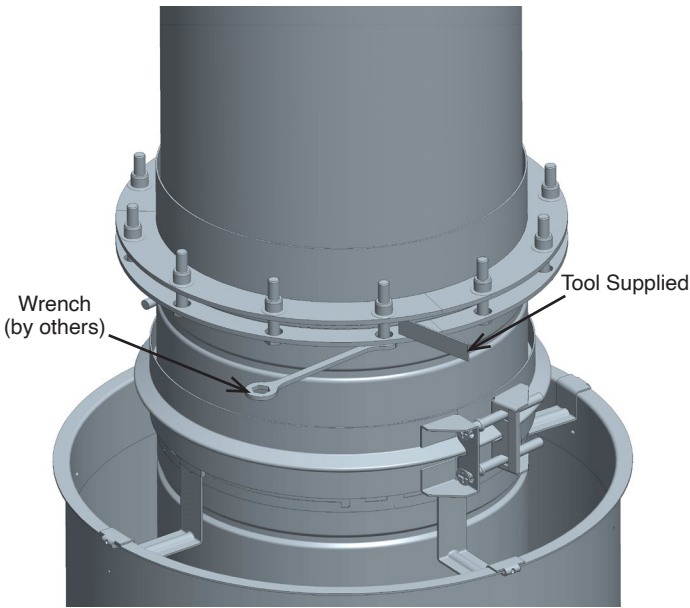

Figure 18 - Step 5 of the Adjustable Length

6. Install the outer pipe casing insulation (and insulation strip Models DIS1, DIS2, DIS4, and DIS3Z) so the side with the bracket goes on the upstream section. See Figure 19.

NOTE: The outer wall must fit loosely and slide freely when the duct expands or contracts.

NOTE: If the outer casing is too long, it may be cut to length by respecting the minimum overlap of 1" with the outer wall of the inlet end section.

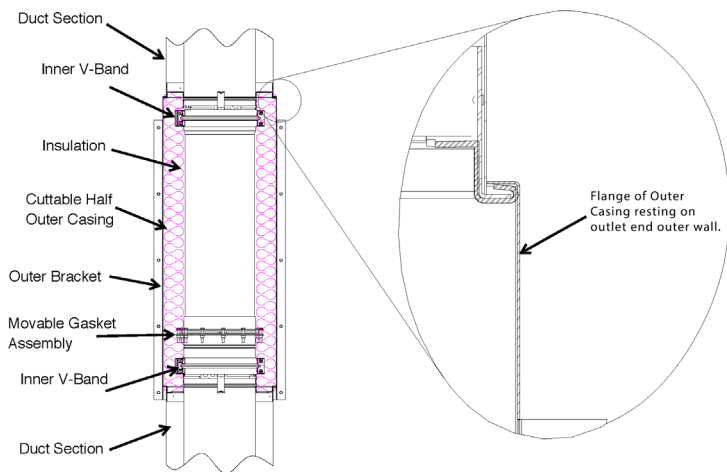

Figure 19 - Installation of Adjustable Length Step 6

VARIABLE LENGTH (LV): For Positive Pressure System and Odd lengths

The Variable Length (LV) has one major function. It makes up odd lengths of duct. It must not be used for expansion compensation.

NOTE: For high positive pressure application, such as on diesel generator exhaust, it is allowed on the outside of the building only.

It is shipped with a flanged retaining band assembly on the inner sliding wall. See Figure 20.

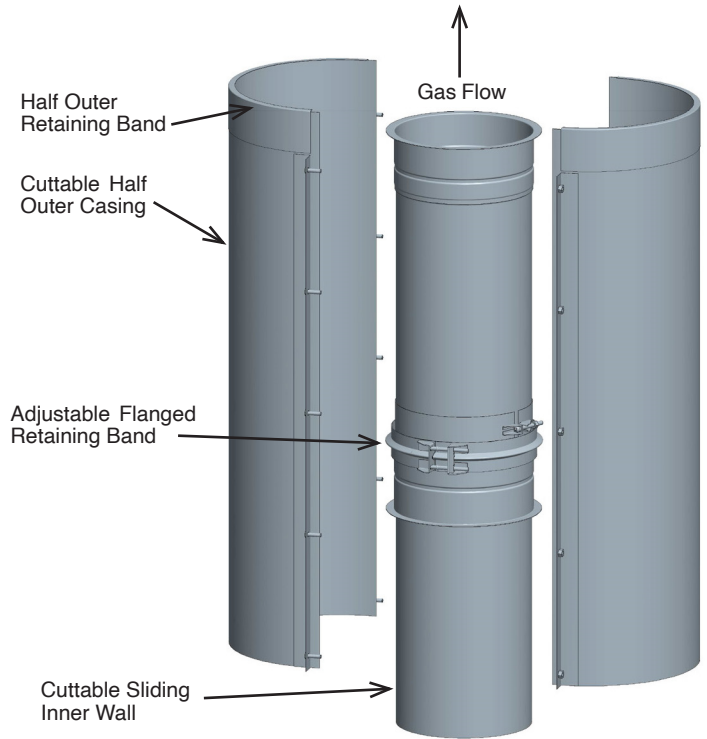

Figure 20 - Variable Length

The whole LV assembly includes:

- A sliding inner wall that fit closely inside a standard pipe section and it is flanged on one side.
- An adjustable flanged retaining band, composed of;
 - Double flanged sleeve
 - Retaining flanged collar
 - An inner V-Band (BSI)
- Insulation band (DIS1, DIS2, DIS4, DIS3Z)
- Split outer casing (DAS1, DIS1, DIS2, DIS4, DIS3Z)

NOTE: Sealant must be ordered separately. See SEALANT USAGE in SECTION C. See Figure 21 for details.

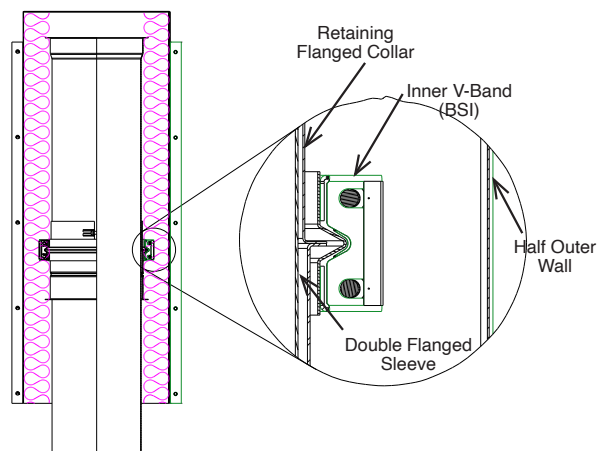

Figure 21 - Detail of Variable Length

Flange to flange length adjustment can range from 7"x 28 1/2"

NOTE: If the flue is too long to fit into the adjacent section of duct without interfering with the flow path, it should be trimmed to desired flange to flange length plus an overlap of 4" with the inner wall of the inlet end duct section. The minimum overlap for the outer casing is 1" with the inlet end section outer wall. See Figure 22).

NOTE: If an LV joint must be joined to one of these fittings, the unflanged end of the tube should always point downward or towards downward slope.

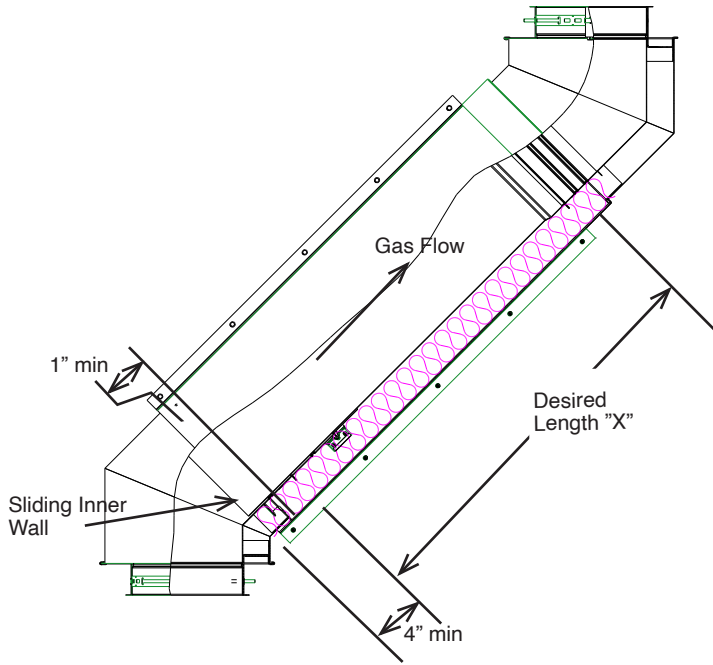

Figure 22 - Overlap Details for Variable Length

INSTALLATION STEPS FOR THE VARIABLE LENGTH (LV)

1. Measure the distance X required for the variable length. See Figure 23.

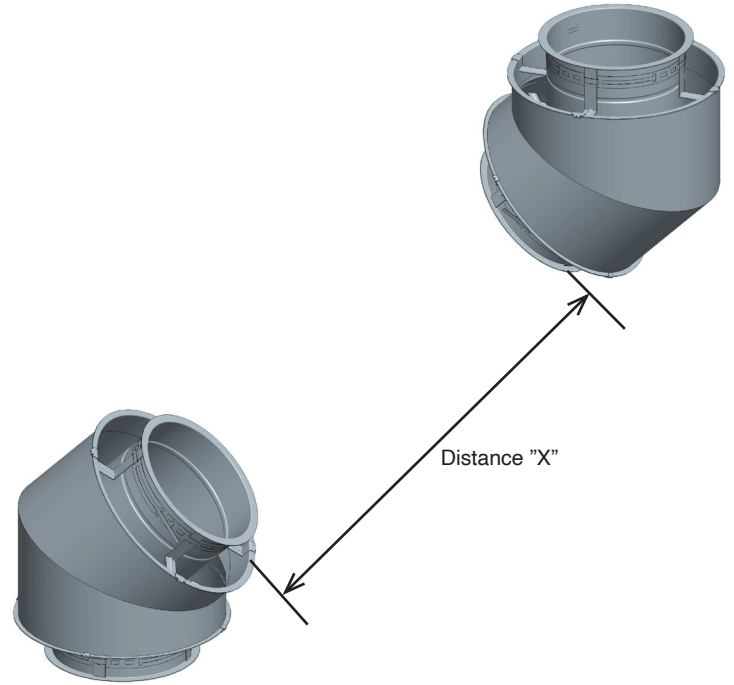

Figure 23 - Step 1 for Installation of Variable Length

2. Cut the inner wall at the dimension X found at the first step + 4". See Figure 24a.
3. Cut the split outer casing at dimension X + 6". See Figure 24b.
4. Then cut the insulation band at dimension X + 6" (DIS1, DIS2, DIS4, DIS3Z). See Figure 24c.

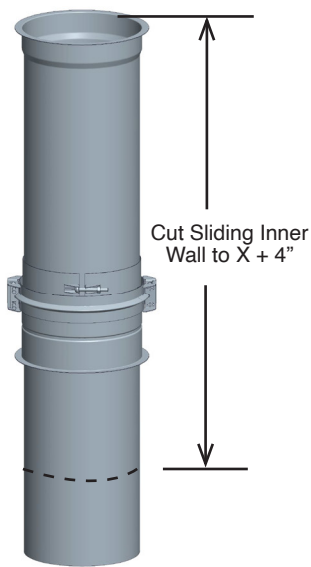

Figure 24a - Step 2 - Cut of the Sliding Inner Wall

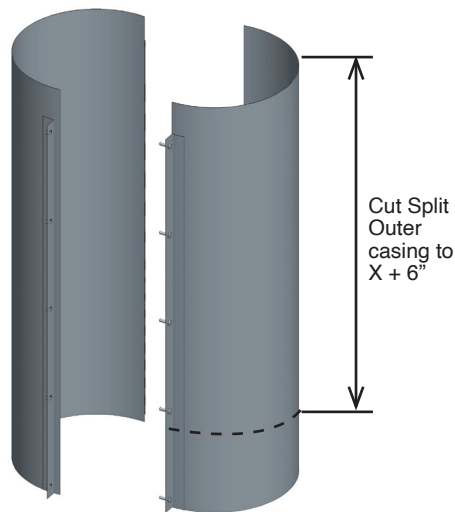

Figure 24b - Step 3 - Cut of the Outer Casing

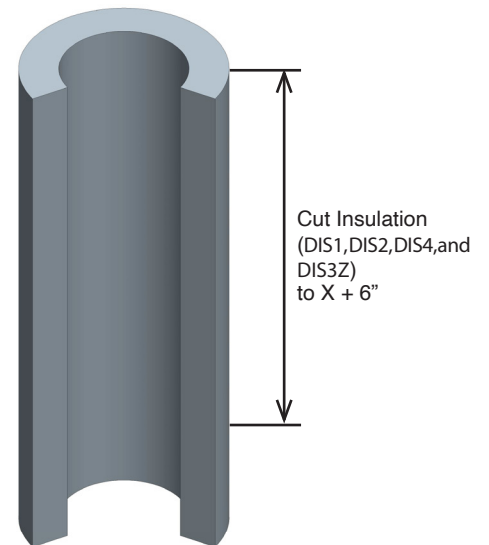

Figure 24c - Step 4 - Cut of the Insulation

NOTE: DIAGRAMS & ILLUSTRATIONS ARE NOT TO SCALE.

5. Install the interior assembly between the two parts. Place the adjustable flanged band assembly toward the downstream section.
6. Assemble the outlet end sliding inner wall to the outlet end section as a regular section (See JOINT ASSEMBLY section). See Figure 25.

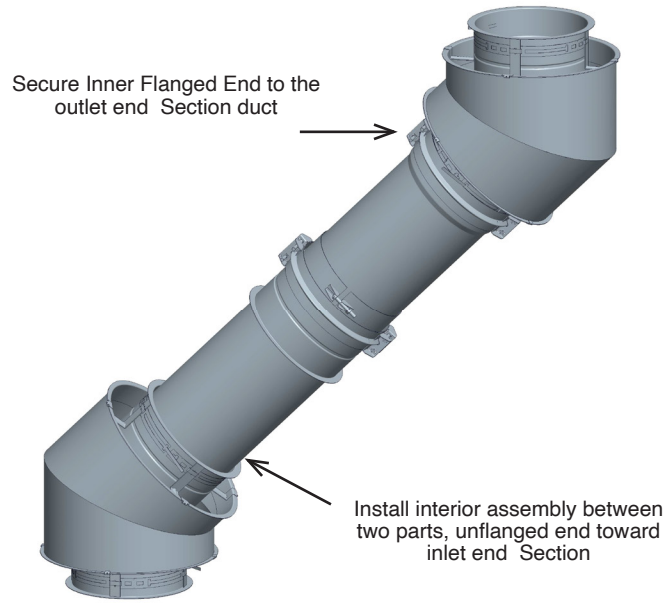

Figure 25 - Step 5-6 - Install the inner LV and secure the outlet end Flange

7. Before assemble the double flanged sleeve to the inlet end section, add a thin coat of sealant about 1" wide a thin coat of sealant at the unflanged end of the LV joint where the joint slides into the mating duct section. Press sealant into any gap between the LV and the mating joint section.
8. Assemble the inlet end flange assembly with the inlet end section flange as a regular length installation (See JOINT ASSEMBLY in SECTION C).
9. Apply thin layer of sealant inside the retaining collar, and also a continuous bead of sealant at the collar overlap seam. See Figure 26.

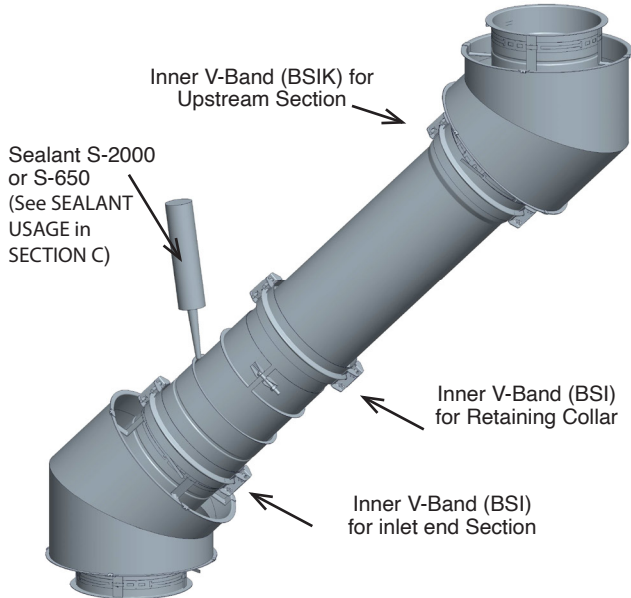

Figure 26 - Step 7-9 - Secure the Double Flanged Sleeve and seal the Retaining Flange Collar

10. Slide down the retaining band on the double flanged sleeve to mate their flanges and tighten the retaining collar.
11. Then install the other V-band (BSI) over these flanges (like regular section joint assembly). See Figure 27.

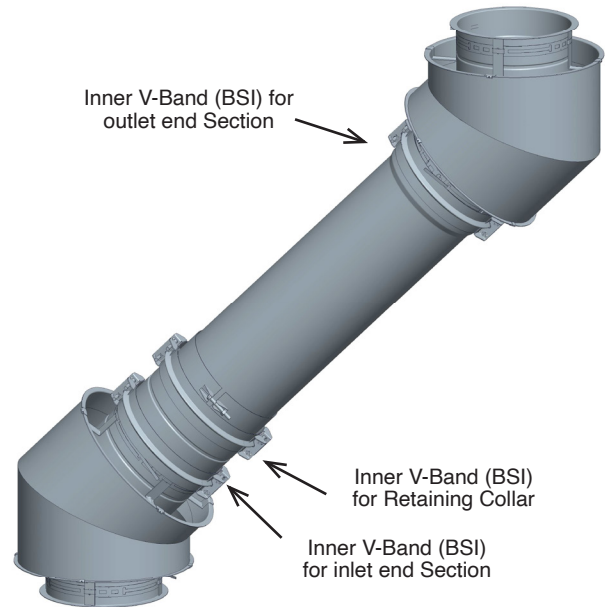

Figure 27 - Step 10-11 - Secure the Retaining Flanged Band

12. Install the insulation over the inner wall (DIS1, DIS2, DIS4, DIS3Z). See Figure 30.

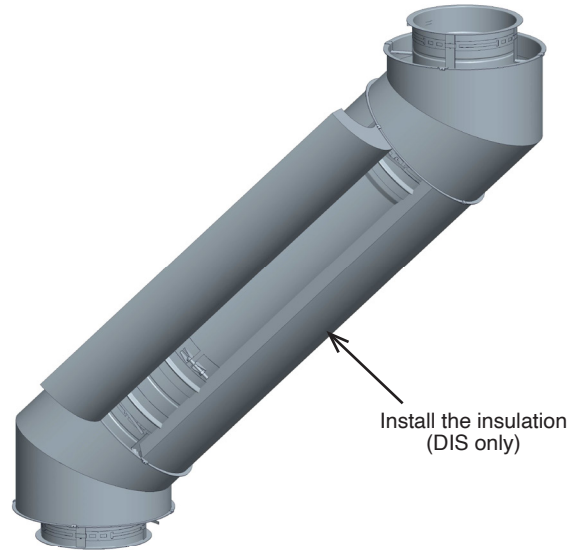

Figure 28 - Step 12 - Install Insulation for LV

13. Install the split outer casing that covers from the outer wall of the inlet end section to the outer wall of the outlet end section. See Figure 29.

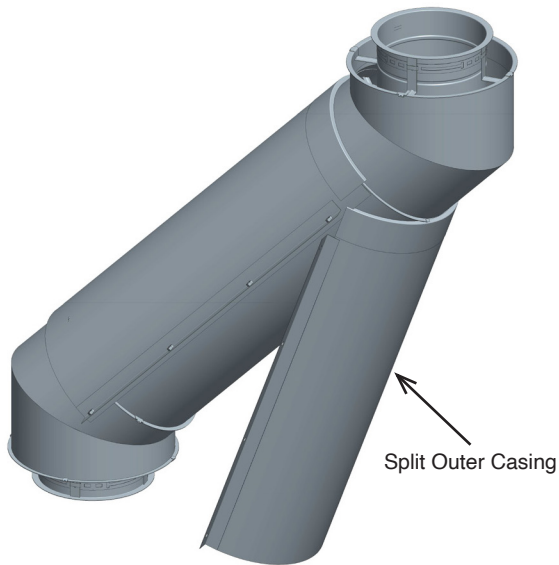

Figure 29 - Step 13 - Install of Split Outer Casing

45° TEE (T45) AND DOUBLE 45° TEE (TD45)

See Figure 31a for the 45° Tee and the Figure 31b for the Tee with two entrances to trunk (the Double 45° Tee).

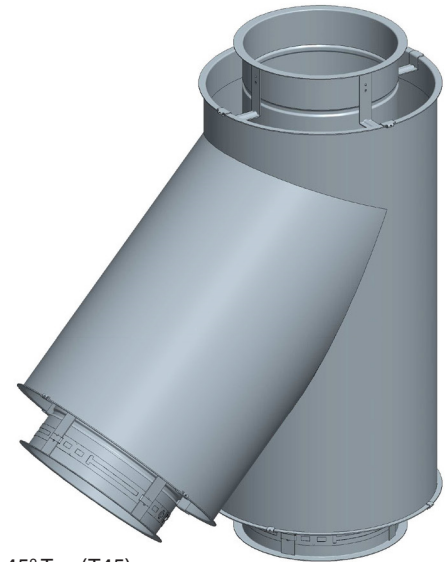

Figure 31a - 45° Tee (T45)

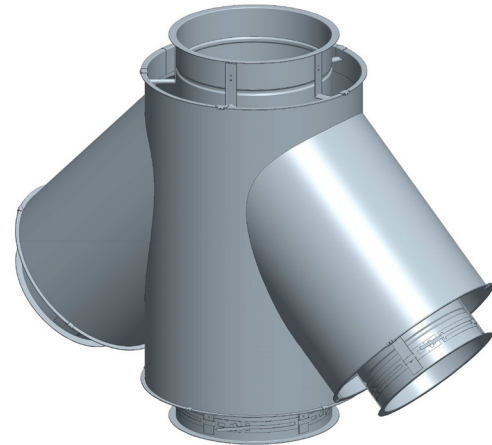

Figure 31b - Double 45° Tee (DT45)

TEES

90° TEE (T90)

The 90° Tee is generally used to connect horizontal connectors into a vertical section as well as a drain or inspection fittings. See Figure 30 for a 90° Tee.

NOTE: For the maximum height of chimney above a based supported Tee, see Table 5 in SECTION B.

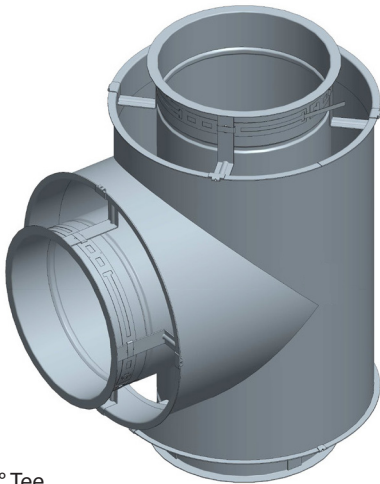

Figure 30 - 90° Tee

LATERAL TEE (BT)

The Lateral Tee (BT) is a 45° Tee with a 45° Elbow integrated in it. The installation details are the same as a 90° Tee. See Figure 32.

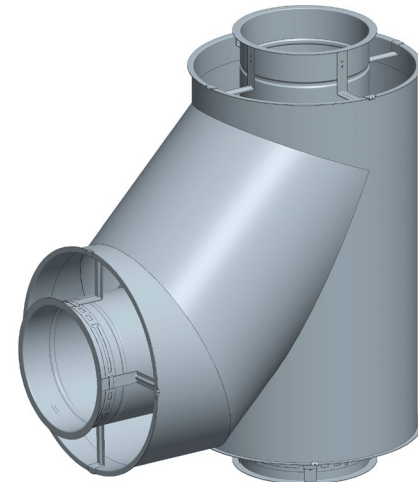

Figure 32 - Lateral Tee (BT)

TEE PRECAUTION

1. Use an Adjustable Length (LA) or a Bellow Length (LB) + Variable Length (LV) in all horizontal breechings or laterals.
2. If more than ¼" of thermal expansion is expected between the tee and the next fixed support point;
 - a. Tees should be protected from bending moments by use of an Adjustable Length (LA) or a Bellow Length (LB) combined with a Variable Length (LV) (See the section on the EXPANSION JOINT, ODD LENGTH AND HIGH PRESSURE SYSTEM)
 - b. And the use of two axis support as in Figure 54 and 55 in TEE SUPPORT section is recommended.
3. Provide access for easy removal of Tee Caps.
4. Never support any Models by the outer casing.

TEE CAP (TC)

The Tee Cap provides access for cleaning and inspection into the chimney. Usually on horizontal runs, the Tee Cap is used to close the unused port of any Tee and for cleanout or access purposes only. When using clean-outs, always seal the connection to prevent leaks and assure that the chimney functions as intended.

The part list includes;

- 1x Cap with one Handle
- 1x smaller V-Band (BSI)

The Next Item are for Models DAS1, DIS1, DIS2, DIS4 and DIS3Z only:

- 1x Outer Casing;
- 1x Insulation Band for Models DIS1, DIS2; and DIS3Z
- 1 or 2x insulation band for Model DIS4
- 1x Insulation Pad for DIS1, DIS2; and DIS3Z, or 2x Insulation pad for DIS4
- 1x Larger inner V-Band (BSI)

INSTALLATION PROCEDURES

- 1 - Apply sealant to duct flue flange and on the Inner Cap (disc with one handle), about a 3/8" bead all around the cap.

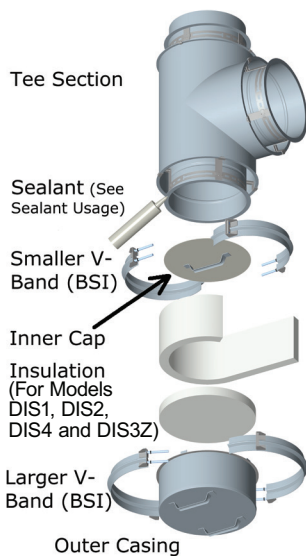

Figure 33a: Tee Cap Step 1

- 2 - Use the smaller inner V-Band (BSI) to secure the cap to the flange of the 90° Tee (T90, not included) as specified in the JOINT ASSEMBLY section

NOTE: Be sure the handle of the cap faces outward as shown. See Figure 33b

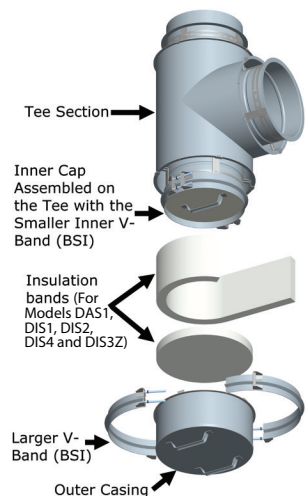

Figure 33b: Tee Cap Step 2

THE NEXT STEPS ARE FOR MODELS DAS1, DIS1, DIS2, DIS4 and DIS3Z ONLY.

- 3 - Then add the insulation pad at the bottom of the casing.

- 4 - Wrap the insulation band around the inner wall of the Tee, up to the spacer/brackets inside the Tee. See Figure 33c.

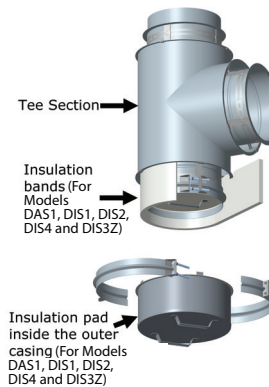

Figure 33c: Tee Cap insulated casing Step 3 and 4

- 5 - Mate the flange of the outer casing with the flange of the out wall of the Tee section.

For a proper installation, make sure that the insulation band goes up to the spacers of the T90.

- 6 - Secure with the bigger V-band (BSI) by tightening the retaining screw. See Figure 33d.

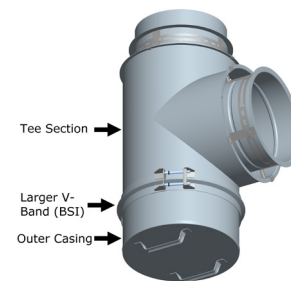

Figure 33d: Tee Cap insulated casing Step 5 and 6

DRAIN TEE CAP (DTC)

The Drain Cap (DTC) is used as a drain for the base of vertical installation and must be connected to a suitable disposable point. It can also be used as an access for cleanouts or access purpose. See Figure 34. Same installation as a Tee Cap (TC).

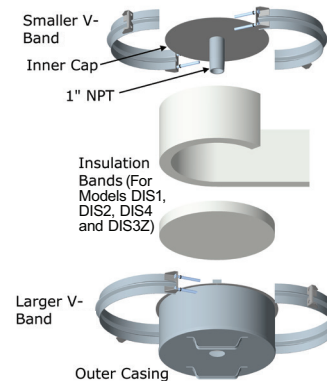

Figure 34: Drain Tee Cap (DTC)

ELBOWS

ELBOWS (E3, E15, E30, E45, E90)

Elbows are used for changes of direction in horizontal or vertical portions of a system. All elbows feature the standard joint assembly as described in JOINT ASSEMBLY section. Elbows are used in combination to make different angles ranging from 3° to 90° in horizontal and vertical segments. See Figure 35a, b, c, d, e for all types of Elbows.

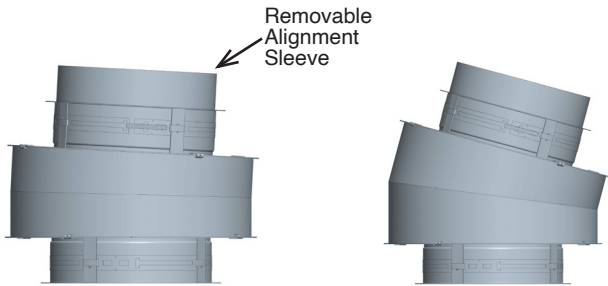

Figure 35a: 3° Elbow

Figure 35b: 15° Elbow

Elbows are not designed to take bending loads or thermal expansion. Thus, Elbows must be structurally supported or protected from thermal expansion. Structural parts such as posts or beams may also be needed to hold chimney supports in position. See ELBOW SUPPORT section.

OFFSETS

- 1- Sloped offsets require more expansion joints and secure bracing above and below elbows.
- 2- The length of the offset is determined by strength considerations. The maximum distance between supports is given in Table 7 and Figure 36b, and is applicable to all horizontal and sloped orientations
- 3- The minimum offset is accomplished with two elbows directly connected to each other (see Figure 36 and Table 10a, b, c, d, e.).
- 4- With frequent re-support, there is no structural or operating limit to the length of horizontal or sloped portions of Models DCL, DAS1, DIS1, DIS2, DIS4 and DIS3Z, providing the system meets the capacity, pressure drop of available equipment.
- 5- The carrying capacity of supports and their structural attachments must take into account the weight of the offset plus whatever vertical sections are carried by that support.
- 6- Height limits for supports are tabulated in SUPPORT METHODS AND HEIGHT LIMITS of these instructions.
- 7- The ends of any sloped or horizontal offset must be anchored to prevent over stressing elbows and to assure proper operation of expansion joints.
- 8- The vertical sections above the offset must also be supported or anchored and guided where necessary.
- 9- Models DCL, DAS1, DIS1, DIS2, DIS4 and DIS3Z Heavy Duty Floor Guide (FGHD), Heavy Duty Wall Support (WSHD) and Heavy Duty Wall Guide (WGHD) may be used in a variety of ways for offset support to achieve the structural stability of the system. Preferred methods of using Models DCL, DAS1, DIS1, DIS2, DIS4, DIS3Z supports are shown in SUPPORTS section.
- 10- Re-supports such as those shown in Figure 56 and 57 must be securely anchored to walls, posts, or locally fabricated rigid framework. This framework must be designed to assure stability of attached Models DCL, DAS1, DIS1, DIS2, DIS4 and DIS3Z supports, such as Anchor Plate (AP) supports and Heavy Duty Wall Supports (WSHD).
- 11- Supports suspended by threaded rods or from small size angles or straps are usually not satisfactory to resist bending moments due to offsets.
- 12- There is no limit on the angle or slope of an offset for gas or liquid fuel burning appliances, but with a solid fuel burning appliance the slope must not be greater than 30° from the vertical. Chimneys for combination fuel heating appliances which are capable of burning solid fuel or are convertible to solid fuel are limited to the same 30° slope even if the current choice of fuel is gas or oil.

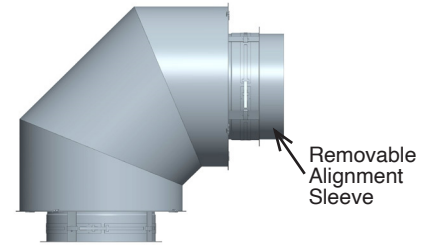

Figure 35e: 90° Elbow

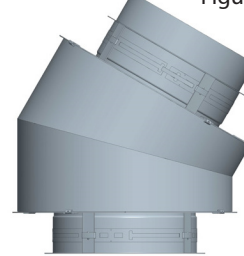

Figure 35c: 30° Elbow

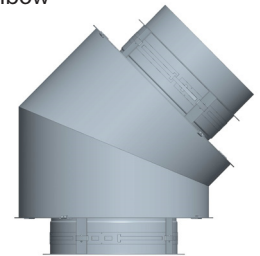

Figure 35d: 45° Elbow

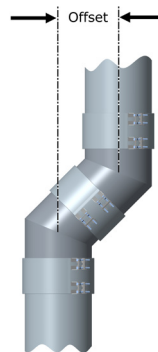

Figure 36a - Offset of two elbows

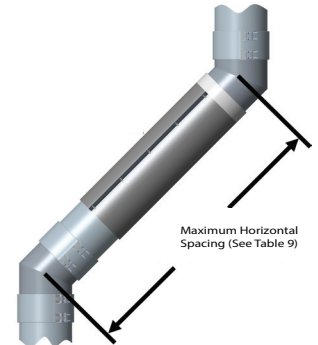

Figure 36b - Maximum Spacing between supports for Offset

Diameter Ø (in.)	3°	15°	30°	45°	90°
5	3/8	2	4 1/8	6 1/4	13 1/4
6	3/8	2	4 1/4	6 5/8	14 1/4
7	3/8	2	4 3/8	6 7/8	15 1/4
8	3/8	2	4 1/2	7 1/8	16 1/4
9	3/8	2 1/8	4 5/8	7 1/2	17 1/4
10	3/8	2 1/8	4 3/4	7 3/4	18 1/4
11	3/8	2 1/8	4 7/8	8	19 1/4
12	3/8	2 1/8	5	8 3/8	20 1/4
13	3/8	2 1/4	5 1/8	8 5/8	21 1/4
14	3/8	2 1/4	5 1/4	8 7/8	22 1/4
16	3/8	2 3/8	5 1/2	9 1/2	24 1/4
18	3/8	2 3/8	5 3/4	10 1/8	26 1/4
20	3/8	2 1/2	6 1/8	10 5/8	28 1/4
22	3/8	2 1/2	6 3/8	11 1/4	30 1/4
24	3/8	2 5/8	6 5/8	11 7/8	32 1/4
26	3/8	2 5/8	6 7/8	12 1/2	34 1/4
28	3/8	2 3/4	7 1/8	13	36 1/4
30	3/8	2 3/4	7 3/8	13 5/8	38 1/4
32	3/8	2 7/8	7 5/8	14 1/8	40 1/4
34	3/8	3	8	14 3/4	42 1/4
36	3/8	3	8 1/4	15 3/8	44 1/4

Dimensions are in inches

Diameter Ø (in.)	3°	15°	30°	45°	90°
5	1/2	2 1/2	5 1/4	8 1/4	18 1/2
6	1/2	2 1/2	5 3/8	8 1/2	19 1/2
7	1/2	2 5/8	5 1/2	8 3/4	20 1/2
8	1/2	2 5/8	5 3/4	9 1/8	21 1/2
9	1/2	2 5/8	5 7/8	9 3/8	22 1/2
10	1/2	2 5/8	6	9 5/8	23 1/2
11	1/2	2 3/4	6 1/8	10	24 1/2
12	1/2	2 3/4	6 1/4	10 1/4	25 1/2
13	1/2	2 3/4	6 3/8	10 1/2	26 1/2
14	1/2	2 3/4	6 1/2	10 7/8	27 1/2
16	1/2	2 7/8	6 3/4	11 3/8	29 1/2
18	1/2	3	7	12	31 1/2
20	1/2	3	7 1/4	12 5/8	33 1/2
22	1/2	3 1/8	7 5/8	13 1/8	35 1/2
24	1/2	3 1/8	7 7/8	13 3/4	37 1/2
26	1/2	3 1/4	8 1/8	14 3/8	39 1/2
28	1/2	3 1/4	8 3/8	14 7/8	41 1/2
30	1/2	3 3/8	8 5/8	15 1/2	43 1/2
32	1/2	3 3/8	8 7/8	16 1/8	45 1/2
34	1/2	3 1/2	9 1/8	16 3/4	47 1/2
36	1/2	3 1/2	9 1/2	17 1/4	49 1/2

Dimensions are in inches

Diameter Ø (in.)	3°	15°	30°	45°	90°
5	1/2	2 3/4	6 1/8	10	24 1/2
6	1/2	2 3/4	6 1/4	10 1/4	25 1/2
7	1/2	2 3/4	6 3/8	10 1/2	26 1/2
8	1/2	2 3/4	6 1/2	10 7/8	27 1/2
9	1/2	2 7/8	6 5/8	11 1/8	28 1/2
10	1/2	2 7/8	6 3/4	11 3/8	29 1/2
11	1/2	2 7/8	6 7/8	11 3/4	30 1/2
12	1/2	3	7	12	31 1/2
13	1/2	3	7 1/8	12 1/4	32 1/2
14	1/2	3	7 1/4	12 5/8	33 1/2
16	1/2	3 1/8	7 5/8	13 1/8	35 1/2
18	1/2	3 1/8	7 7/8	13 3/4	37 1/2
20	1/2	3 1/4	8 1/8	14 3/8	39 1/2
22	1/2	3 1/4	8 3/8	14 7/8	41 1/2
24	1/2	3 3/8	8 5/8	15 1/2	43 1/2
26	1/2	3 3/8	8 7/8	16 1/8	45 1/2
28	1/2	3 1/2	9 1/8	16 3/4	47 1/2
30	1/2	3 1/2	9 1/2	17 1/4	49 1/2
32	1/2	3 5/8	9 3/4	17 7/8	51 1/2
34	1/2	3 3/4	10	18 1/2	53 1/2
36	1/2	3 3/4	10 1/4	19	55 1/2

Dimensions are in inches

Diameter Ø (in.)	3°	15°	30°	45°	90°
5	1/2	2 5/8	5 1/2	8 3/4	20 1/2
6	1/2	2 5/8	5 3/4	9 1/8	21 1/2
7	1/2	2 5/8	5 7/8	9 3/8	22 1/2
8	1/2	2 5/8	6	9 5/8	23 1/2
9	1/2	2 3/4	6 1/8	10	24 1/2
10	1/2	2 3/4	6 1/4	10 1/4	25 1/2
11	1/2	2 3/4	6 3/8	10 1/2	26 1/2
12	1/2	2 3/4	6 1/2	10 7/8	27 1/2
13	1/2	2 7/8	6 5/8	11 1/8	28 1/2
14	1/2	2 7/8	6 3/4	11 3/8	29 1/2
16	1/2	3	7	12	31 1/2
18	1/2	3	7 1/4	12 5/8	33 1/2
20	1/2	3 1/8	7 5/8	13 1/8	35 1/2
22	1/2	3 1/8	7 7/8	13 3/4	37 1/2
24	1/2	3 1/4	8 1/8	14 3/8	39 1/2
26	1/2	3 1/4	8 3/8	14 7/8	41 1/2
28	1/2	3 3/8	8 5/8	15 1/2	43 1/2
30	1/2	3 3/8	8 7/8	16 1/8	45 1/2
32	1/2	3 1/2	9 1/8	16 3/4	47 1/2
34	1/2	3 1/2	9 1/2	17 1/4	49 1/2
36	1/2	3 5/8	9 3/4	17 7/8	51 1/2

Dimensions are in inches

Diameter Ø (in.)	3°	15°	30°	45°	90°
5	1/2	2 5/8	5 3/4	9 3/8	22 1/2
6	1/2	2 5/8	5 7/8	9 5/8	23 1/2
7	1/2	2 3/4	6	9 7/8	24 1/2
8	1/2	2 3/4	6 1/8	10 1/4	25 1/2
9	1/2	2 3/4	6 3/8	10 1/2	26 1/2
10	1/2	2 3/4	6 1/2	10 3/4	27 1/2
11	1/2	2 7/8	6 5/8	11 1/8	28 1/2
12	1/2	2 7/8	6 3/4	11 3/8	29 1/2
13	1/2	2 7/8	6 7/8	11 5/8	30 1/2
14	1/2	2 7/8	7	12	31 1/2
16	1/2	2 1/2	7 1/4	12 1/2	33 1/2
18	1/2	3 1/8	7 1/2	13 1/8	35 1/2
20	1/2	3 1/8	7 3/4	13 3/4	37 1/2
22	1/2	3 1/4	8 1/8	14 1/4	39 1/2
24	1/2	3 1/4	8 3/8	14 7/8	41 1/2
26	1/2	3 3/8	8 5/8	15 1/2	43 1/2
28	1/2	3 3/8	8 7/8	16	45 1/2
30	1/2	3 1/2	9 1/8	16 5/8	47 1/2
32	1/2	3 1/2	9 3/8	17 1/4	49 1/2
34	1/2	3 5/8	9 5/8	17 3/4	51 1/2
36	1/2	3 3/4	9 7/8	18 3/8	53 1/2

Dimensions are in inches

INCREASERS AND REDUCERS

Frequently, a diameter change is required in a chimney installation. To accomplish such a size change, a step increaser or tapered increaser may be used. These parts are usually used to provide an increase of size, as the name implies. However, the Tapered Increaser can be turned to Tapered Reducer to reduce the size of a run. Extreme caution should be exercised when reducing the size of a chimney. The resultant pressure drop may cause the chimney to mis-function and cause spillage of flue gases into the mechanical room.

The step increaser should be used when the length of run available for the size change is restricted. The step increaser is a non-structural part and must not be subjected to loading in either the axial or lateral direction.

TAPERED INCREASER (TINØ) and TAPERED REDUCER (RDØ)

The Tapered Increaser Adapter is used for a diameter change in duct system. Uses when there is a sufficient length for duct run available for the size change. The TINØ uses 2" of length per 1" increment diameter change. The TINØ is considered to have the same load strength as a straight duct. See Figure 37.



Figure 37 - Tapered Increaser Adapter (TINØ)

ECCENTRIC TAPERED INCREASER (ETINØ)

The Eccentric Tapered Increaser Adapter is similar as the Tapered Increaser Adapter except the smaller diameter is offset from the larger diameter. When installed horizontally, the ETINØ keep a flat slope unlike the TINØ. See Figure 38.

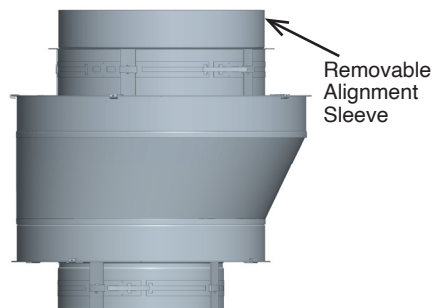

Figure 38 - ECCENTRIC TAPERED INCREASER (ETINØ)

STEP INCREASER (INØ)

The Step Increaser (INØ) should be used when the length of run available for the size change is restricted. The step increaser is a non-structural part and must not be subjected to loading in either the axial or lateral direction. See Figure 39.

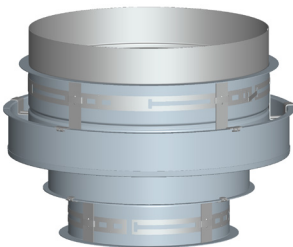

Figure 39 - STEP INCREASER (INØ)

PLATE AND WALL SUPPORT

ANCHOR PLATE (AP)

Anchor Supports are designed to provide support to vertical sections and provide fixed-point support for horizontal sections. See Figure 40.

NOTE: Rings installed at 90° to plates.

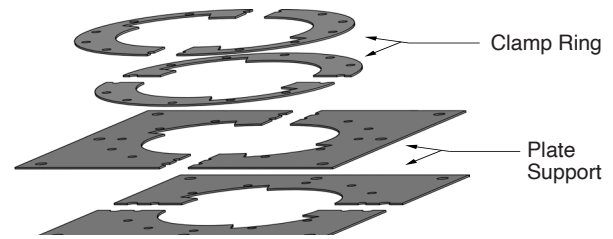

Figure 40 - Anchor Plate

The Plate Support must be attached to the building structure or supported with rigid structural members. See Table 5 for maximum supported height.

A Plate Support is to be attached only to non-combustible construction such as block, concrete or steel with clearance that is adequate for installation and access.

For maximum support, the entire perimeter of the Plate Support must be attached to structural framing. Structural members are supplied by the installer.

WARNING: RISK OF FIRE - DO NOT ATTACH THE PLATE SUPPORT TO COMBUSTIBLE CONSTRUCTION

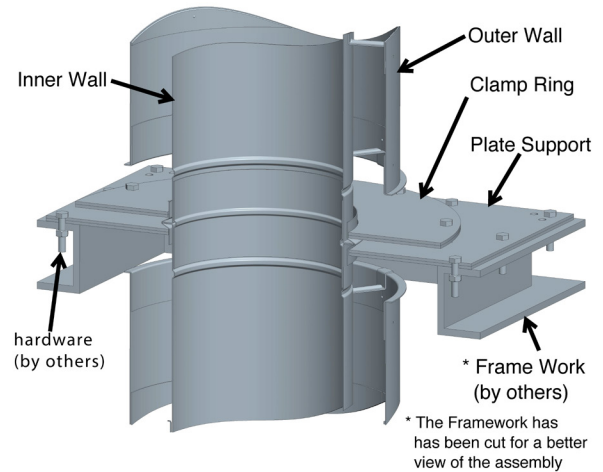

Figure 41a - Anchor Plate on Framing

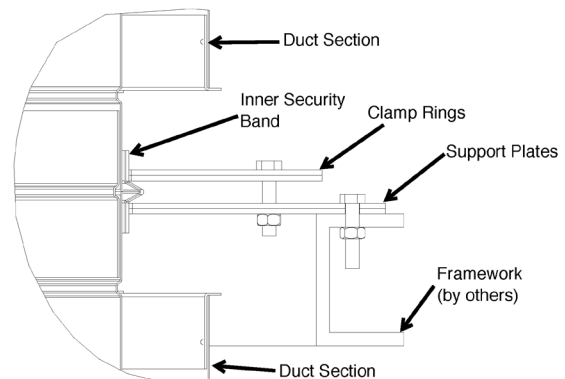

Figure 41b - Detail of Anchor Plate on Framing

Supported duct sections subject to thermal expansion or in a vertical position must be braced with diagonal members or gussets to prevent deflection of the supported joint as shown in Figure 42. "X" is a minimum of 30°.

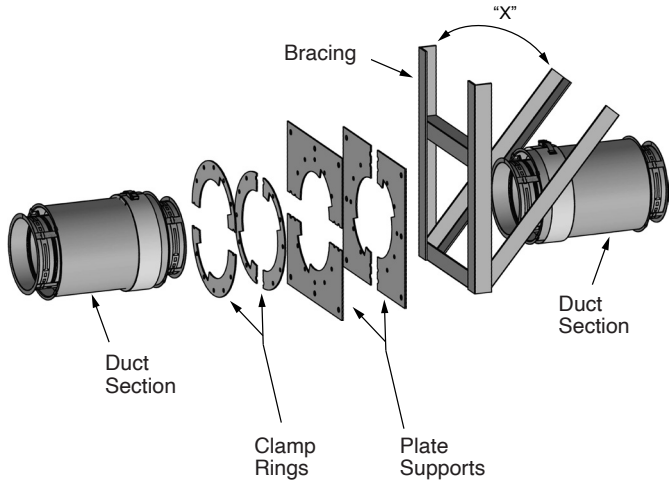

Figure 42 - Anchor Plate Horizontal Bracing

Plate Supports are usually located adjacent to fittings, such as tees or elbows, to protect fitting from expansion stresses. Table 11 shows Plate Support, bracing and framework requirements for duct size ranges.

NOTE: If bracing is used, minimum "X" angle is 30°. If there is no bracing, the framework must be attached to structural members to provide equivalent rigidity.

TABLE 11 - Minimum Acceptable Size for Framework and Bracing for all Models			
Duct Diameter Ø (in)	Plate thickness (in)	Bracing (in)	Framework (in)
Ø5 @ Ø22	3/16	2 x 2 x 3/16 Channel or equivalent	2 x 2 x 1/4 Channel or equivalent
Ø24 @ Ø36	1/4	3 x 3 x 1/4 Channel or equivalent	3 x 3 x 1/4 Channel or equivalent

Dimensions are in inches

ANCHOR PLATE WITH LENGTH (APL)

The APL is an anchor plate integrated on a length. It cannot be used as a fixed support for vertical or horizontal installation because the anchor plate is free to move on the longitudinal axis of the length. Refer to the Anchor Plate (AP) for all the warnings / details, except for the installation. See Figure 43 for detail of APL.

For all models no outer wall is supplied. It is the Outer Band (BSE) that serves as the outer wall.

CAUTION: Small brackets must be on the bottom side so these can hold the outer band (BSE) against the support plates and to make sure the anchor plate is positioned in the middle of the inner wall when installed. See Figure 43 to 46.

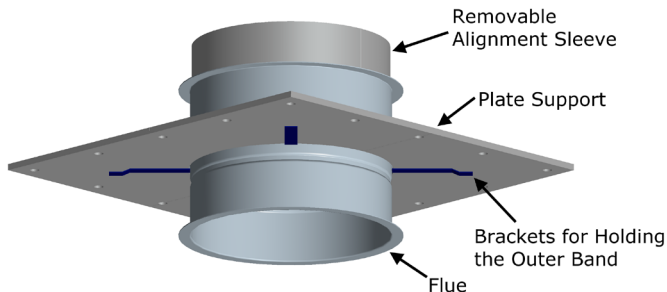

Figure 43 - Anchor Plate with Length (APL)

WARNING: Risk of fire - do not attach the plate support to combustible construction

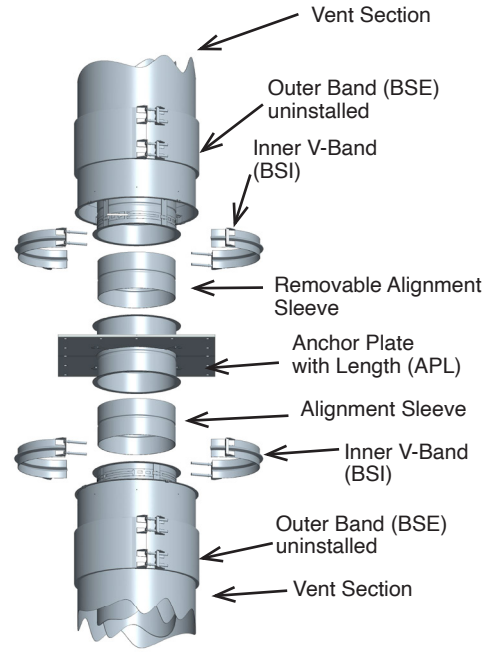

Figure 44 - Step 1 of installation of APL

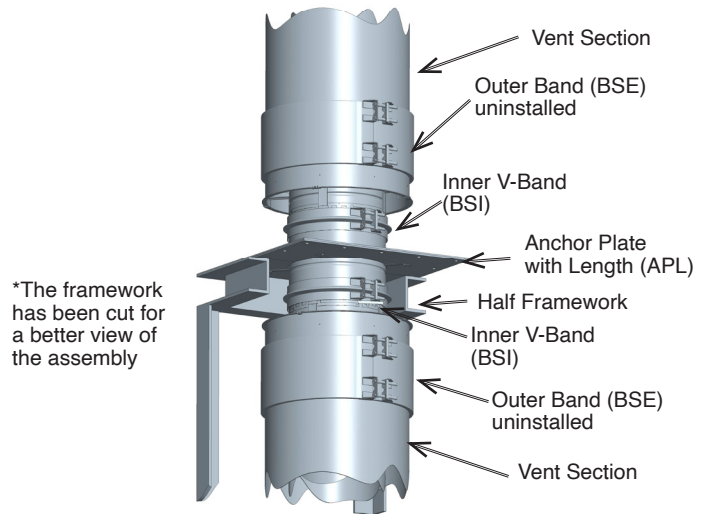

Figure 45 - Step 2 of installation of APL

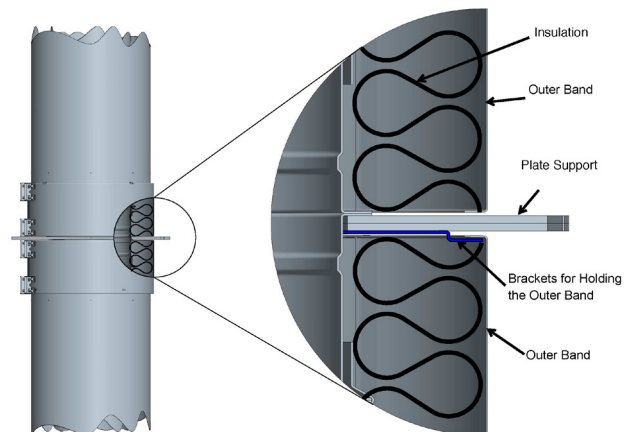

Figure 46 - Step 3 of installation of APL

HEAVY DUTY WALL SUPPORT (WSHD)

When attached to a non-combustible wall with brackets and struts, a Heavy Duty Wall Support makes up a fixed-point (See Figure 47a). The clamp rings are installed with the splits 90° apart so that they support each other. The notches in the clamp rings are aligned with the draw screws of the flange band. The Heavy Duty Wall Support Assembly is bolted together with provided hardware. It is made with adjustable struts, which allow a variable clearance from the non-combustible wall to the outer casing.

The minimum clearance varies with the size of the wall support, but is between 2" and 2 1/2" (based on the angle shape of the Full Angle Ring (FAR). See Figure 47b. The maximum clearance for all sizes is around 10". See Figure 47c.

WARNING: Do not attach Wall Support to combustible construction.

NOTE: Wrap duct joint with insulation before attaching half closure band.

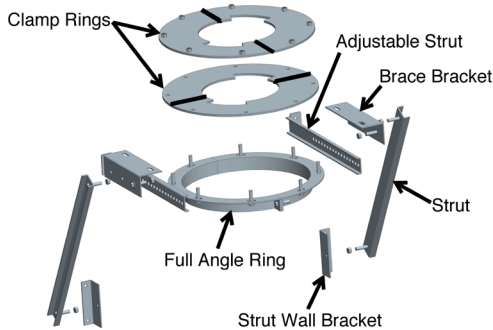

Figure 47a- Wall Support (WSHD)

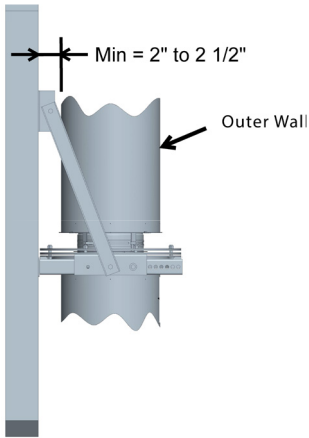

Figure 47b - Minimum Adjustment

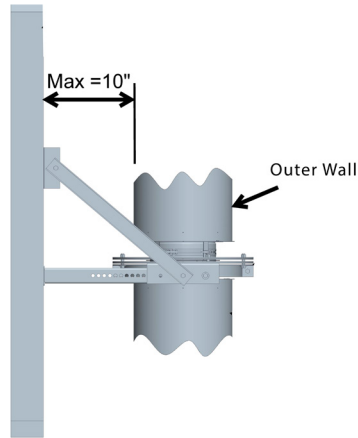

Figure 47c - Maximum Adjustment

HEAVY DUTY WALLGUIDE (WGHD)

The Heavy Duty Wall Guide is designed to complement the Heavy Duty Wall Support (See Figure 48). Placed around the outer wall of the section, it used as a lateral guide to prevent flexing due to lateral loading. The proper location for the WGHD is immediately below the Half Outer Band (DBSE) near the duct joint. The outer band must be able to move away from the Heavy Duty Wall Guide when thermal expansion occurs. The Heavy Duty Wall Guide is bolted together with hardware provided to form a rigid assembly.

NOTE: Seal joint with S-375 sealant above and below support if exposed to weather.

NOTE: The wall guide may be attached to combustible construction. Maintain proper clearances.

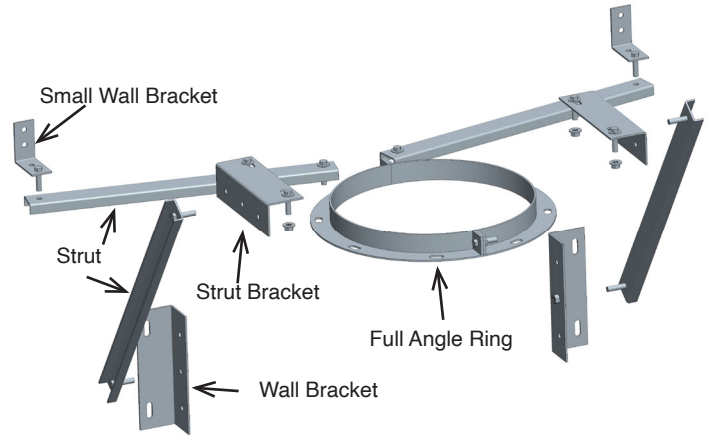

Figure 48 - (WGHD) Minimum Adjustment

HEAVY DUTY FLOOR GUIDE (FGHD)

A Heavy Duty Floor Guide is similar in function to a Heavy Duty Wall Guide or Full Angle Ring, but is modified specifically for use at floor penetrations. The angle brackets and straps hold the FGHD centered in floor penetration. Refer to the Table 2: Opening in Floor / Wall / Roof on page 4 for the value of "X" on the Figure 49.

NOTE: May be attached to combustible construction

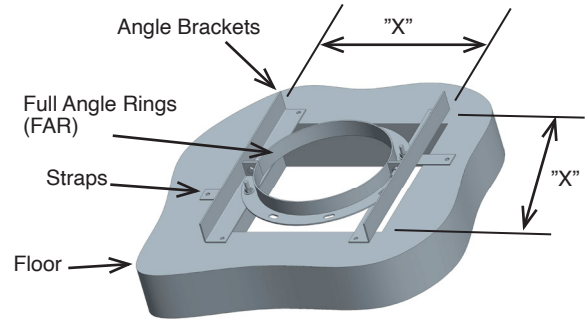

Figure 49 - Heavy Duty Floor Guide (FGHD)

FULL ANGLE RING (FAR)

A Full Angle Ring is used as a guide to prevent the duct from flexing due to lateral loading. The angle ring is split for ease of installation. It is 1/8" larger inside diameter than the outside diameter of the duct to allow movement of the duct inside the ring.



Figure 50- Full Angle Ring (FAR)

HALF ANGLE RING (HAR)

A Half Angle Ring is used as a saddle in horizontal or sloped runs.



Figure 51- Half Angle Ring (HAR)

SECTION E - LOCATION OF SUPPORTS

NOTE: For Grease Duct application, refer to Section I, Grease Duct location of support.

Supports can be used in different combinations to secure chimney in place. See Figure 5 and 6, for typical support and guide locations.

ADJUSTABLE, VARIABLE and BELLOW LENGTH SUPPORT

To prevent the LV, LA or LB from sagging, it is recommended that the chimney section adjacent to a LV, LA or LB is supported or guided. See Figure 52 for typical support locations for Adjustable and Variable Length.

When necessary, properly guide an adjustable length by installing a Heavy Duty Wall Guide (WGHD) or any supports immediately below the chimney joint on the adjacent section.

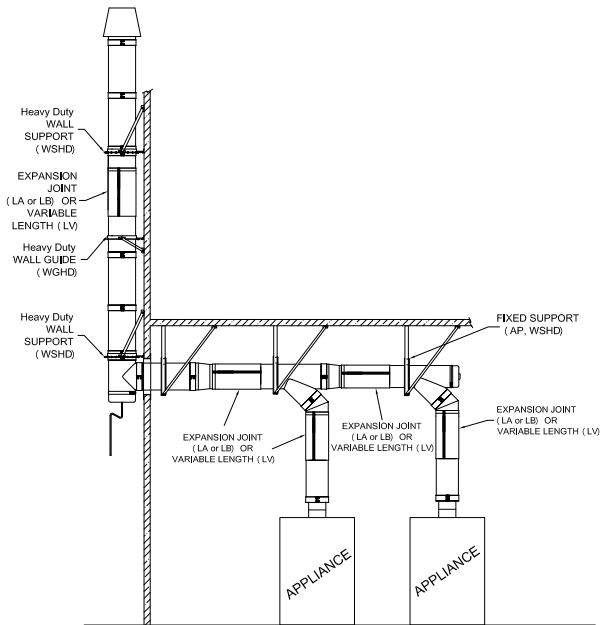

Figure 52 - Typical Installation locations for the Variable and Adjustable Lengths

NOTE: Both LV, LA and LB overlapping joints are not intended to support any weight in the vertical position. The inlet and outlet ends must each be supported.

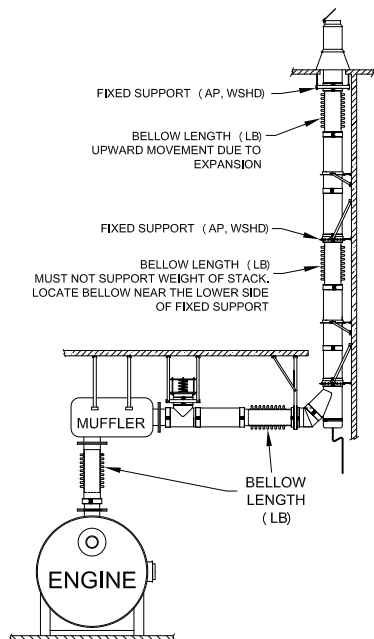

Figure 53- Location for Bellow Lengths

TEE SUPPORT

The Tees must be supported properly to protect them from bending. It can be done by means of Anchor Plate (AP), or Heavy Duty Wall Support (WSHD).

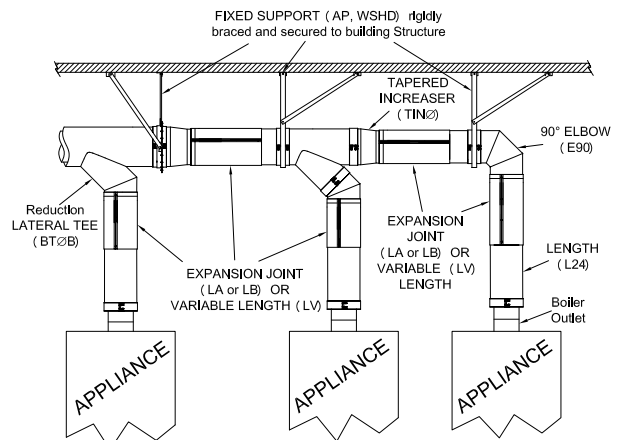

Figure 54- Support for Multiple Tees

When a tee is used at the base of the riser, the preferred location for support is above the Tee, thus suspending the Tee. The Anchor Plate with Length (APL) can be used only as a free support on its axis (vertical or horizontal). See Figure 55.

A Heavy Duty Wall Support (WSHD), an Anchor Plate (AP) or an Anchor Plate with length (APL) can be used to support the TEE.

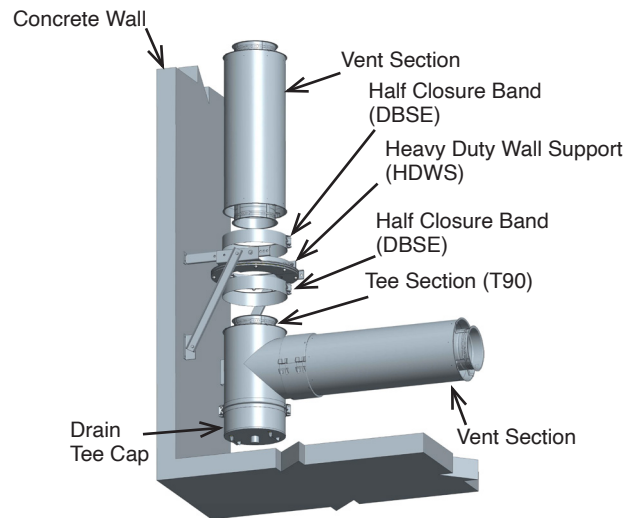

Figure 55- Suspended Tee Support

NOTE: In the case of an Anchor Plate (AP), refer to Figure 41a and 41b for installation. For the Anchor Plate with Length (APL), Refer to a Figure 43 to 46. If it is not possible to suspend the Tee, it may be supported from the base (See Table 5) for maximum height for a base Supported Tee. When this type of support is necessary, access to the drain cap may be hindered. A structural steel stand can be used to allow access to the Tee Cap (TC) or Drain Tee Cap (DTC).

ELBOW SUPPORT

Elbows are to be supported on one end with either a fixed support: Anchor Plate (AP), or a Heavy Duty Wall Support (WSHD). See Figure 56 for an example with an AP and Figure 57 for an example with a (WSHD).

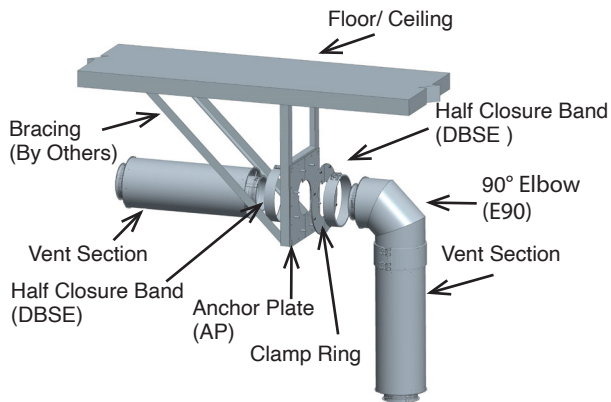

Figure 56- Elbow with an Anchor Plate (AP)

NOTE: In the case of an Anchor Plate (AP), refer to Figure 41a and 41b for installation.

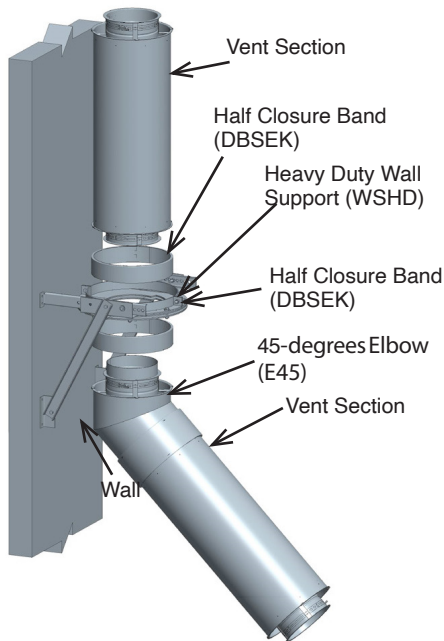

Figure 57- Elbow with a Heavy Duty Wall Support

SECTION F - WALL, FLOOR AND ROOF PENETRATION, GUYING AND BRACING.

NOTE: For Grease Duct application, refer to section K.

A chimney that has to penetrate through a floor, roof or wall made of COMBUSTIBLE materials, must use a Roof Thimble (RT) or a Wall Thimble (WT). The minimum air space clearance between the outer wall of the chimney and the combustible material of the roof / floor / wall listed in the Table 1 & 2 must always be respected when using a Roof Thimble (RT) or a Wall Thimble (WT). See Table 3 for dimensions of the opening in the floor / wall to respect the clearances.

ROOF THIMBLE (RT)

The Roof Thimble (RT) is used when a chimney passes through a floor or roof made of combustible materials. The specific clearances in Table 1 & 2 must always be respected. See Table 3 for dimensions of the opening in the floor / wall to respect the air space clearances.

The Roof Thimble is made of a square plate with a radiation shield on it, to protect the combustible material inside the hole of the floor/ceiling. Four angles are added on the hole side of plate to be sure it won't fit if the hole in the floor doesn't respect the clearance. See Figure 58a.

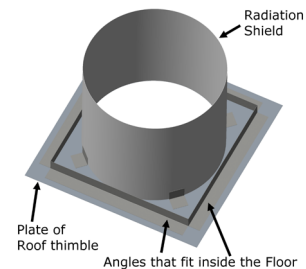

Figure 58a - Roof Thimble (RT)

The radiant shield may need to be trimmed to fit the height of the floor. The RT is designed to be installed on a flat roof. They may be installed on a pitch roof if a curb is installed to provide a flat surface. Guides or Supports must be used either on top or under the floor/roof/ceiling to ensure that the chimney is well centered in the Roof Thimble (RT).

When a Flashing (F) and a Storm Collar (SC) are used on top of the roof, use the exterior sealant S-375 to seal the Storm Collar (SC) on the outer casing with the outer joint sealant.

Do not installed a chimney joint or a expansion length in the roof/floor space.

Installation:

1. Cut opening to dimensions specify in Table 3.
2. The plate of the Roof Thimble must be installed under the floor / ceiling, with angles and radiation shield inside the hole.
3. Slide chimney through the Roof Thimble
4. Install guide under the floor.

Note: When there is thermal expansion, make sure to have the expansion distance calculated (with the expansion formula on page 5) between the guide and an outer band (BSE) of a joint section.

5. Install a Flashing (F) on the top of the floor over the chimney, screw it and seal it with the outer sealant S-375.
6. Add the Storm Collar (SC)
7. Seal with the outer sealant S-375 the Storm Collar (SC) on the outer wall of the section.

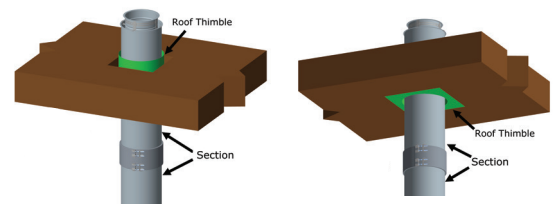

Figure 58b - Roof Thimble installed

WALL THIMBLE (WT)

Wall Thimble (WT) is used when a chimney passes through a wall made of combustible materials.

The part consist of a roof thimble female half and a male roof thimble half that slide in each other to adjust wall thickness from 8" to 12". The specific clearances in Table 1 & 2 must always be respected. See Table 3 for dimensions of the hole opening in the wall to respect the air space clearance.

This assembly is made of a two parts. See Figure 59a.

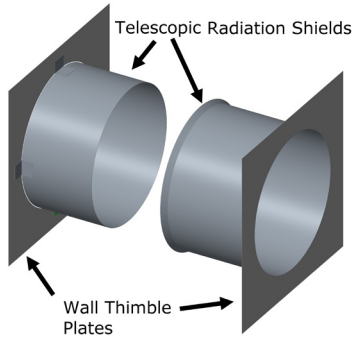

Figure 59a - Wall Thimble (WT)

Installation:

1. Cut opening in the wall to dimension indicated in Table 3.
2. On one side of the wall, slide the Female half in the opening and fix it to the wall with screws.
3. On the other side of the wall, slide the male half into the opening and fix it to the wall with screws.

NOTE: A minimum overlap of 2" must be made between the male half into the female half.

4. Insert the chimney through the opening of the Wall Thimble (WT).
5. The chimney must be well supported or guided on both side of the wall to prevent any load or offset of the chimney in the Wall Thimble.

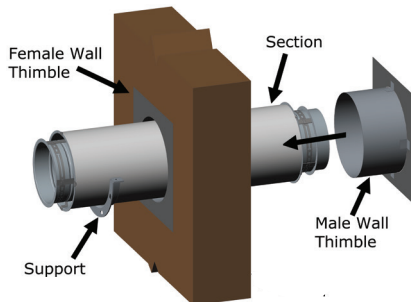

Figure 59b - Supports for Chimney passing through a Wall

THROUGH WALL SUPPORT

Chimney that penetrate wall have to be supported at least on one side of the wall, supporting the section that penetrates through the wall. It can either be supported by bracing a Half angle Ring (HAR), Anchor Plate (AP), or Anchor Plate Length (APL) See Figure 59c

NOTE: Refer to Table 3 for minimum opening in combustible material.

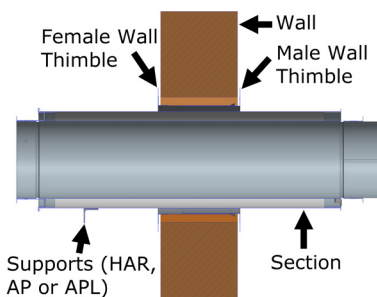

Figure 59c - Supports for Chimney passing through a Wall

FLASHING (F)

The roof Flashing (F) is used in conjunction with Storm Collar (SC) for weatherization on a flat roof. See Figure 60 and 61.



Figure 60 - Storm Collar

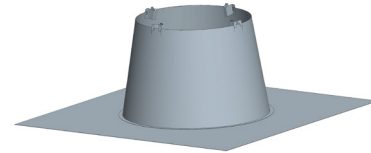

Figure 61 - Flashing

ADJUSTABLE FLASHING (F30)

The Adjustable Flashing (F30) is used in conjunction with Storm Collar (SC) for weatherization on a roof with a pitch 5° to 30°. See Figure 62.

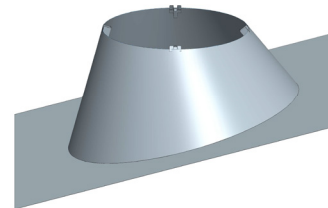

Figure 62 - Adjustable Flashing

NOTE: The flashings are non-ventilated and does not provide for any reduced clearance to combustible.

INSTALLATION PROCEDURE FOR FLASHINGS

1. Cut opening to dimensions specified in Table 3. See Figure 61 for flat roof and Figure 62 for a sloped roof.

NOTE: Reinforced the edges of the hole as appropriate for the expected lead bearing requirements.

2. Slide chimney through the hole.
3. For lateral stability, supports or guides must be used. The Heavy Duty Floor Guide (WSHD) must be installed either on top or under the roof (See Figure 64b for guide under the roof). Any supports (AP, APL or WSHD) or a Full Angle Ring must be installed below.

NOTE: Flashing is not intended to take any side load or wind loads

4. Install flashing over the chimney and the guide/support, screw it and seal it with the outer sealant S-375.
5. The Storm Collar (SC) is placed around the chimney and sealed to the casing with outer joint sealant S-375.

The storm collar should not quite rest on the flashing when the chimney is cold (a 1/4" gap between the collar and the top of the flashing).

NOTE: Maintain adequate spacing for expansion from the floor and the outer band (BSE) that is under the floor.

NOTE: If the maximum freestanding duct height above the Anchor Plate (AP), Anchor plate with length (APL) or Full Angle Ring (FAR) exceeds that shown in the Table 5 and Table 6, guying is required.

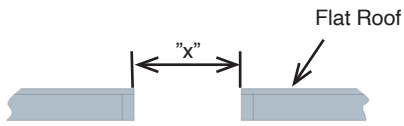

Figure 63a - Minimum Opening for flat roof

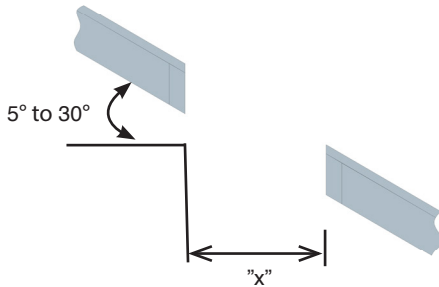

Figure 63b - Minimum Opening for sloped roof

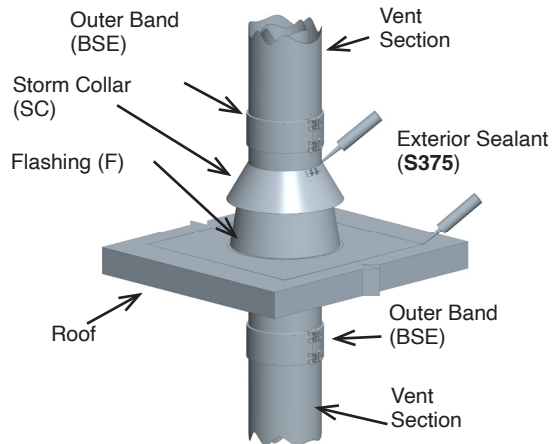

Figure 64a - Installation of Flashing- View Top of the Roof

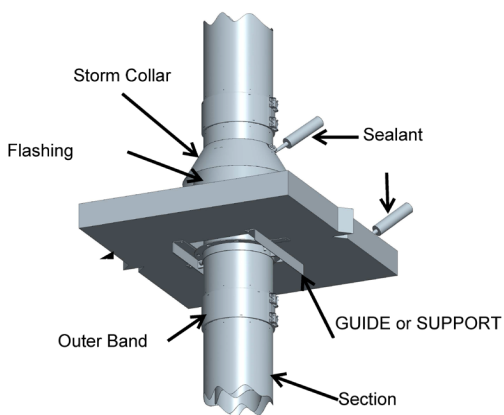

Figure 64b - Installation of Flashing- View under the Roof

GUYING AND BRACING

1. Proper guying and bracing is essential for part of the Chimney that extends above the roof or parapet wall. The chimney at this point is subject to wind conditions and needs special attention for proper stabilization. See Figure 65.
2. If the chimney above the roof does not exceed dimension H in Table 6, no special guying or bracing is required. However, to protect the flashing from lateral movement, a guide must be installed at the roof level. See Figure 65.
3. To minimize the effect of thermal expansion, good practice implies installing a fixed support and an expansion length at the roof level.
4. When using guy wire, the cable must be slightly slack or loose to allow thermal expansion or be equipped with tensioning springs (by others). The tensioning springs are mandatory only when there is more than one level of guy wire needed.
5. When rigid Brace (by others) are used, the maximum distance between the last fixed support and the band of the roof brace must be reduced to 5' to minimize loads induced by thermal expansion on braces and support,
6. Make sure to have a rigid structure on the roof.

The Guy Ring (GR) consist of half clamps installed on the on the inner wall flanges of a joint of two sections. The Clamp rings have holes at 60° apart, to have the choice of adding guy wires (by others) at 120° (Ø5 to Ø20) or 60° apart. The guy wires are fixed to the roof by the mean of tensioner or anchor (by others). Rigid Brace can also be used on the Guy Ring. The Storm Collar (SC) is placed around the chimney and sealed to the casing with outer joint sealant S-375. See Figure 66a for parts included in the Guy Ring and Figure 66b for one installed..

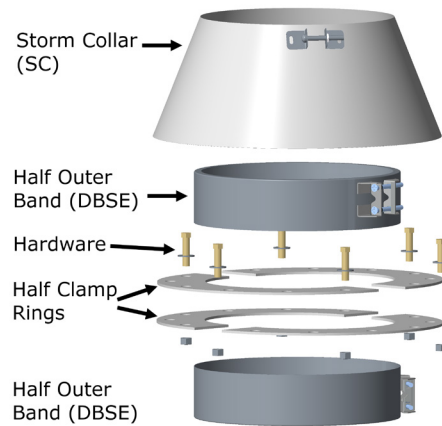

Figure 66a - Guy Section Details

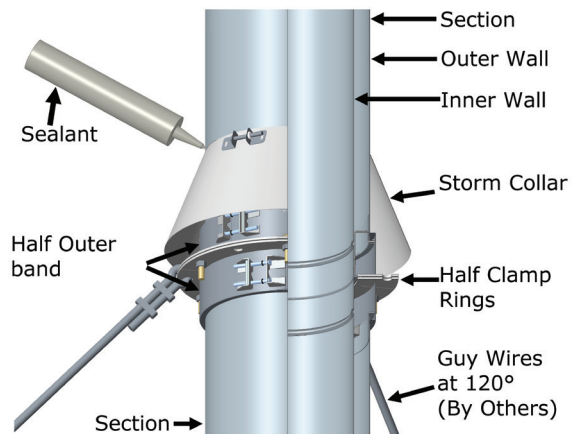

Figure 66b - Guy Section Installed

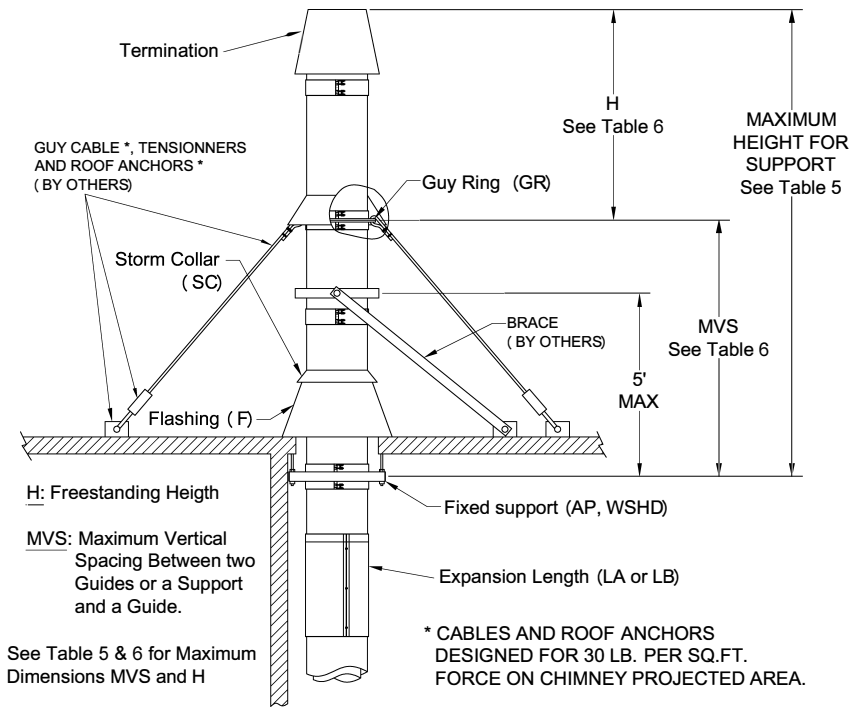

Figure 65 - Height with rigid bracing or guying option

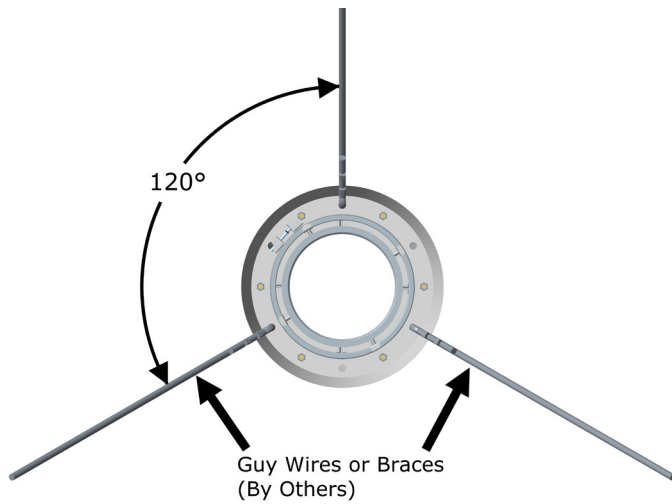

Figure 66c - Guy Section Details

SECTION G - TERMINATION, STARTING ADAPTERS, DRAINING SECTIONS, RELIEF VALVE AND ACCESSORIES

TERMINATION - GENERAL

An upward discharge (such as with a Finishing Cone (FC) or open top) provides the most effective means of dispersing chimney gases into the atmosphere and away from immediate surroundings. Such termination however will allow entry of rain unless there is upward flow at high velocity. A Rain Cap (RC) is only partially effective in excluding rain. Its effectiveness depends on chimney gas flow rate, raindrop characteristics and wind velocity. For diesel or turbine exhaust, a Flip Top (FT) can be used for vertical chimney and the Miter Cut (MC) for horizontal discharge. For a termination with a very low flow resistance loss, but maximum protection from rain, a No Loss Cap (NLC) can be used on vertical run. If an Outer Band (BSE) or a Closure Ring (CR) is used with the termination, it must be sealed to the section with outer sealant S-375.

FINISHING CONE (FC)*

The Finishing Cone (FC) is a single wall construction (for Model DCL) or a Double wall construction (for Models DAS1, DIS1, DIS2 and DIS4), where the inner wall is straight, but the outer wall is a cone. It attaches with a standard Inner V-Band (BSI) and Outer Band (BSE) (See JOINT ASSEMBLY Section) to the uppermost chimney pipe section. To prevent rain from reaching an appliance this installation requires use of a Drain Length (DL) in a vertical run or a Drain Tee Cap (DTC) at the end of a vertical chimney. See Figure 67.

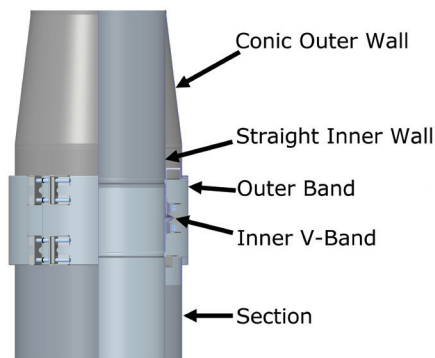
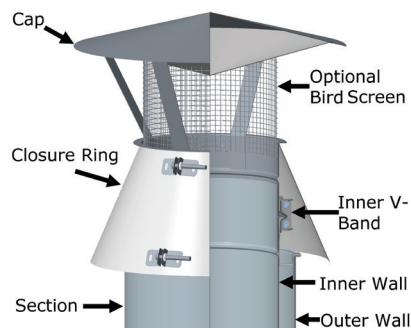

Figure 67- Exit Cone (EC) installed

RAIN CAP (RC) OR RAIN CAP WITH BIRD SCREEN (CRCB)

The Rain Cap combine partial protection against rain entry with low exit flow (resistance is roughly 0.5 velocity heads). It is mounted to the end of a standard pipe section by use of the standard Inner V-Band (BSI). See Step 1 to 4 in the JOINT ASSEMBLY Section. It is a single wall assembly (for all Models DCL, DAS1, DIS1, DIS2 and DIS4), but a Closure Ring (CR) is provided as part of the Rain Cap so that the insulating space is protected through the upper end of the chimney. The CR must be seal to the inner wall with outer Sealant S-375. See Figure 68.

Figure 68 - Rain Cap (RC) installed



FLIP TOP (FT)*

Used in vertical diesel or turbine exhaust, it prevents moisture and debris from entering the system. It opens with internal pressure and closes when no pressure. It is a single wall part (for all Models DCL, DAS1, DIS1, DIS2 and DIS4), that is attached on the uppermost chimney pipe section with a inner V-Band (BSI)

(See Step 1 to 4 in the JOINT ASSEMBLY Section). For Models DAS1, DIS1, DIS2 and DIS4, a Closure Ring (CR) is provided to protects the insulated space between standard pipe inner and outer. If a FT is installed on a horizontal termination, the hinged side of the top must be oriented at the top of the pipe keeping the counterweight up. The CR must be seal to the inner wall with outer Sealant S-375. See Figure 69.

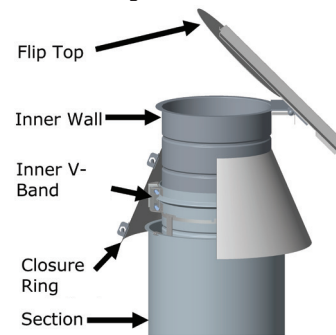

Figure 69 - Flip Top (FT) installed

MITER CUT (MC)

The Miter Cut a double wall construction and is intended for use as a termination for a horizontal engine exhaust. It is designed to minimize the entry of rainwater when installed in the proper orientation. It is equipped with a birdscreen at the end of the Miter Cut. The MC must be installed so that the long side of miter is on the top of the pipe to afford protection from rain. See Figure 70.

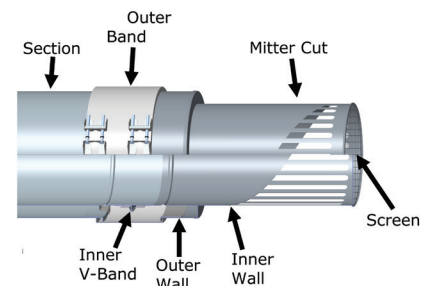

Figure 70 - Miter Cut (MC) installed

NO LOSS CAP (NLC)*

The No Loss Cap is a "low loss" termination and is recommended by the American Conference of Government Industrial Hygienists (ACGIH): Industrial Ventilation Manual, 23rd Edition, Figure 5-30. Only as a vertical cap, it is designed to eliminate back-pressure on positive-pressure exhausting equipment while still protecting the equipment from the rain. This allows your equipment to operate as efficiently as possible and also allows the exhaust to blast unhindered straight up with full velocity. The last 6" of the inner flue is surrounded by a

larger outer wall (I.D. +2") that has a height of 4 times the flue diameter and is open at the bottom. The Closure Ring (CR) must be seal to the inner wall with outer Sealant S-375. Rain water that falls into the larger wall washes down the side of the larger chimney and discharges at the bottom. See Figure 71a.

For I.D. from 5" to 13", the No Loss Cap is an integral component that attaches to the chimney flue using a standard inner V-Band (BSI) (See JOINT ASSEMBLY Section). For Models DAS1, DIS1, DIS2 and DIS4, a Closure Ring (CR) is provided to protects the insulated space between standard pipe inner and outer. See Figure 71a.

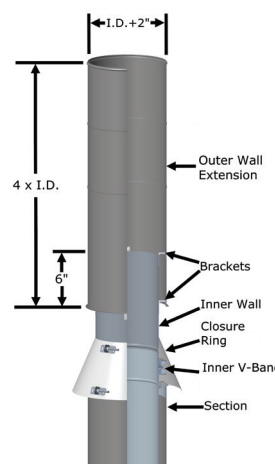

Figure 71a - No Loss Cap (NLC) installed or I.D. from 5" to 13"

NOTE: DIAGRAMS & ILLUSTRATIONS ARE NOT TO SCALE.

*NOTE: At present July 2018, UL LLC has no safety standard for these devices, so although they are shown in this document and condoned by Duravent and others, UL has not independently investigated.

For I.D. from 14" to 36", the No Loss Cap include an 12" inner wall that attaches to the chimney flue using a standard inner V-Band (BSI) (See JOINT ASSEMBLY Section). The outer wall is made of different combinations of single wall DCL Length that has a diameter 2" larger than the flue diameter to have the right height for each diameter (4 x I.D.). The DCL section must be built up on an Anchor Plate (AP) and a framework (by others) attached to the building, overlapping the inner flue by 6". See Figure 71b.

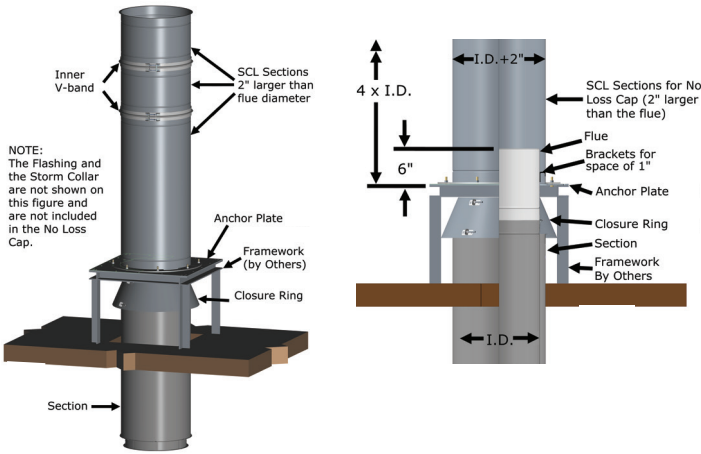

Figure 71b and c - No Loss Cap (NLC) installed for I.D. from 14" to 36"

DRAINING SECTIONS

If rain is to enter the Chimney, install a Drain Length (DL) at least 5 pipe diameters below the chimney outlet, but above any Tee or Elbows. A Drain Tee Cap (DTC) at the base of a vertical run can also be used. If the system is under pressure, use a "P" trap at least the same height of the maximum pressure of the system.

DRAIN LENGTH (DL)

A Drain Length (DL) is used to drain water on vertical runs. It is an 18" pipe length with provision to drain rain or condensate from the chimney. The pipe flue is equipped with an annular catch gutter wall and a 1" (25) NPT nipple extending through the casing for attachment of drain piping. See Figure 72. The drain piping should include a water leg of a height at least equal to the maximum expected operating pressure at the appliance outlet to avoid allowing flue gases to vent through the drain. Drain Length should be installed indoors to prevent freezing.

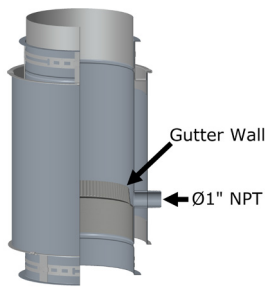

Figure 72 - Drain Length (DL).

HORIZONTAL DRAIN LENGTH (HDL)

The Horizontal Drain Length (HDL) has the same function and dimensions as the Drain Length (DL), but used on horizontal run and has a dam just below the NPT Drain instead of a gutter. The dam directs the water through the drain. See Figure 73.

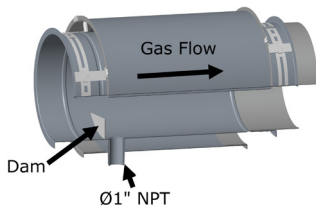

Figure 73 - Horizontal Length (HDL)

NOZZLE LENGTH (NL)

The Nozzle Length NL is used when there is a need for test port. Same size as the Drain Length (DL). See Figure 74.

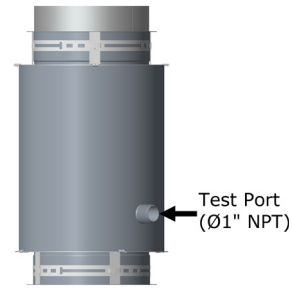

Figure 74 - Nozzle Length (NL)

RELIEF VALVE FOR EXCESSIVE PRESSURE

RELIEF VALVE (RV)*

The Relief Valve (RV) is designed for installation in the exhaust system of stationary Internal Combustion Engines (Diesel Engine). It's function is to protect engine exhaust components from damage due to engine exhaust explosions (backfire). It is recommended to add a Relief Valve on each Diesel Engine Exhaust System and should be installed as close to the engine exhaust outlet as is safely possible to prevent damage to system.

The RV is intended to help control the venting of pressure which may occur during an exhaust system backfire. Engines have the potential to inject unburned fuel into an exhaust system during start up or due to an engine malfunction.

This unburned fuel creates a condition where a backfire could occur. The RV will help prevent damage to other parts such as Flex Connectors, Silencers, Catalytic Converters, Convolved Bellows and Heat Recovery Equipment. It can also limit exhaust back pressure on the engine.

Further precedence for use of the Relief Valves can be found in NFPA 37, "Standards for the Installation and Use of Stationary Combustion Engines and Gas Turbines".

MAINTENANCE OF THE RELIEF VALVE IF USED OUTDOORS: Apply an exterior grade high heat paint to the Guide Plate, Valve Seat, Valve Plate, and Flange Adapter to ensure maximum corrosion resistance. (Ex. Rustoleum V2100 series High Heat Industrial Aerosol).

CAUTION: This device is designed to relieve excessive pressure (30" w.c. with standard springs) in the case of an engine malfunction for the sole purpose of protecting the physical integrity of the exhaust system and related parts. If such malfunction occurs, the device will release hot gases, sparks and/or flames into the immediate vicinity of the RV. As such, this device should never be installed where human contact with any such release is possible, or near flammables or combustibles like gas canes, oils, or other such materials.

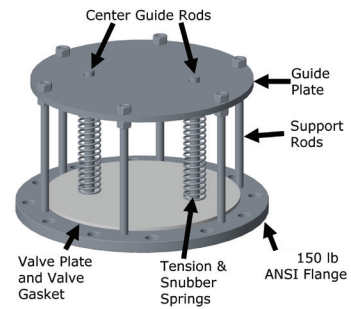

Figure 75a - Relief Valve (RV)

The Relief Valve (RV) consists of a spring loaded disk valve mounted on ANSI flange. See Figure 75a.

Additional flange gasket and bolt set (supplied by others) by others should be used for the connection to our 125/150 lb ANSI Flange Adaptor (FA). The gasket and bolts are typically sold by pipe, valve and fittings houses as an "NBG" (Nut, Bolt Gasket Kit) set. The valve is factory calibrated to open at 27 in. of water column. The calibration nuts must not be changed or the valve may not function correctly. If additional tension is required due to normal operating pressures exceeding 27" of w.c., additional auxiliary springs may be obtained by contacting Duravent.

Installation:

1. The Relief Valve (RV) should be located in the beginning of the system.
2. The orientation of the Relief Valve must be positioned upright, as shown on the Figure 75b with a 45° Tee (T45) or on Figure 75c with a 90° Tee (T90).
3. The Relief Valve must be connected to our ANSI Flange Adaptor (FA). Bolts, washers, nuts, and gasket (supplied by others) will provide a complete gas tight connection to the 125/150 lb. ANSI flanged Flange Adapter.
4. The Relief Valve and the ANSI Flange Adaptor must be connected to one of our Tees (T90 or T45).
5. The Relief Valve (RV) must be supported independently of the rest of the exhaust system. The best method to accomplish this is to locate an Anchor Plate (AP) support at the joint between the ANSI Flange Adaptor (FA) and the adjacent Tee (T45 or T90). It is crucial that the Anchor Plate (AP) is properly secured to building structure so that it can withstand the forces generated in case of delayed fuel ignition.

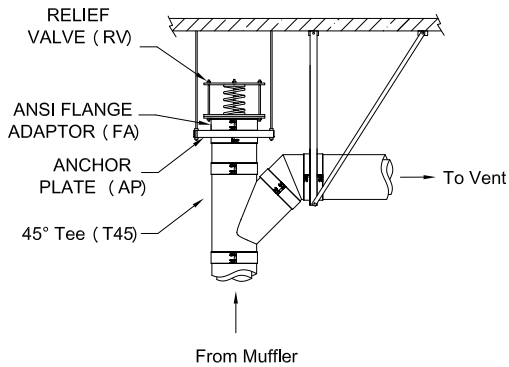

Figure 75b - Typical installations with a 45° Tee and a ANSI Flange Adaptor (FA)

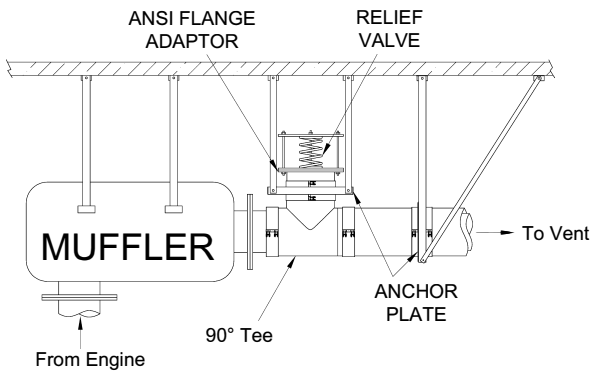

Figure 75c - Typical installations with a 90° Tee and a ANSI Flange Adaptor (FA)

APPLIANCE AND FLANGE CONNECTIONS

SINGLE WALL ADAPTOR (SWA)

The Single Wall Adaptor SWA is the most commonly used appliance connector. It is designed to clamp with a Retaining Band and Locking Band (BS) over a shank type flue gas outlet.

Installation:

1. Slide the Retaining Band over the appliance outlet and tighten it with supplied bolt.
2. Add a bead of sealant about 1/8" on the flange of the Retaining Band and another bead on the flange of the Flue of the Adaptor SWA and mate those two flanges together. Be sure to fill all the gap with the right sealant, depending on what appliance it is used (See SEALANT Section).
3. Put the Inner wall on the Retaining band.
4. Tighten the Locking Band (BS) to hold and seal the adaptor in place. See Figure 76.

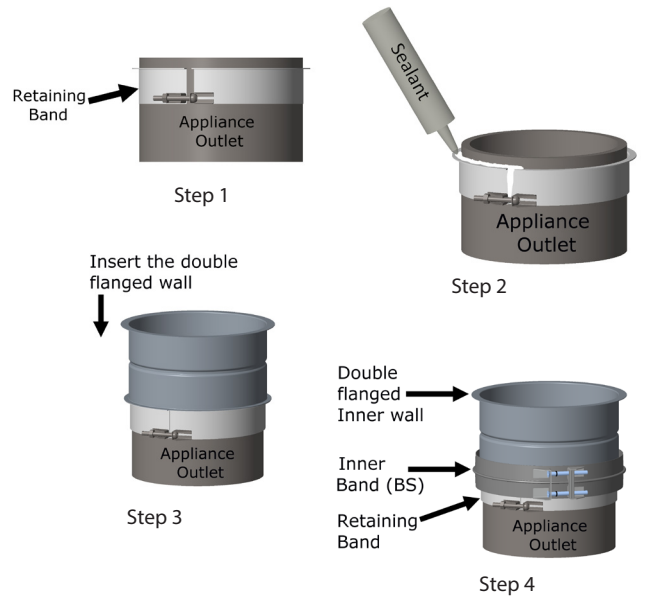

Figure 76 - Installation of a Single Wall Adaptor (SWA) on an appliance

SINGLE WALL ADAPTOR WITH NOZZLE (SWAN)

The Single Wall Adaptor with Nozzle SWAN is the same as the SWA, but it has a nozzle for test port. See Figure 77.

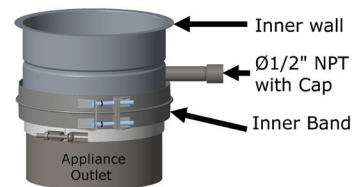

Figure 77 - Single Wall Adaptor with Nozzle (SWAN) installed on an appliance

ANSI FLANGE ADAPTOR (FA)

The Flange Adaptor FA is intended for use as a connection to a class 125 or 150 ANSI pipe flange. This type of connection requires a flange gasket and bolt set supplied by the installer. The gasket and bolts are typically sold by pipe, valve and fittings houses as an "NBG" (Nut, Bolt Gasket Kit) set.

An additional Outer Band (BSE) is included and acts as the outer wall.

INSTALLATION:

1. Place the Gasket kit (by others) on the appliance's flange.
2. Mate all together the FA, the gasket and the Appliance's flange.
3. Place and tighten all the bolt and nuts kit (by others) in every hole of the ANSI Flange,
4. Do Step 1 to 4 of JOINT ASSEMBLY Section to install a section on the 1/2 flange side of the FA with the inner V-Band (BSI).

For DIS1, DIS2 and DIS4 only:

5. Add insulation around the FA.

For DAS1, DIS1, DIS2 and DIS4:

6. Add the Outer Band (BSE) around the FA, acting as an outer wall.

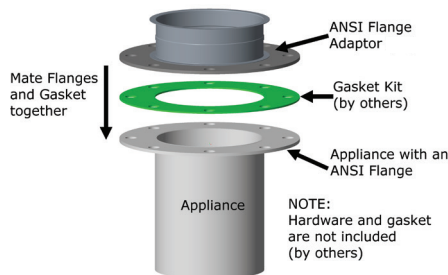

Step 1-2

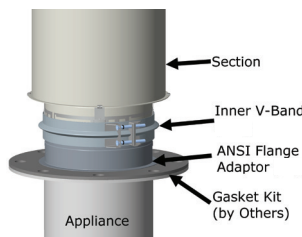

Step 3-4

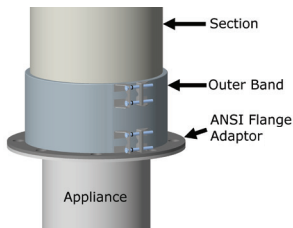

Step 5-6

Figure 78 - Installation of an ANSI Flange ADAPTOR (FA)

HALF UNIVERSAL FLANGE (HUF)

The Half Universal Flange (HUF) is designed to connect Models DCL, DAS1, DIS1, DIS2 and DIS4 pipe to a boiler or other appliance having a flanged outlet with a 4, 6, 8, 12, 16, 24 or no bolt pattern at all.

The HUF is a four flat 1/8" thick steel clamp rings supplied in two half-circle pieces with 24 slots $\text{Ø}3/8" \times 1"$ (for $\text{Ø}5$ to $\text{Ø}24$) and 36 slots (for $\text{Ø}26$ to $\text{Ø}36$), equally spaced around the face of the adaptor. No hardware included.

See Figure 79 for installation on a bolt pattern flange. See Figure 80 for an installation on an appliance that have a flange without holes.

INSTALLATION ON A FLANGE WITH BOLT PATTERN:

1. Apply a continuous bead of sealant to the face of the pipe flange and to the appliance flange.
2. Mate the pipe flange with the appliance
3. Position two half clamp rings over the pipe's inner wall flange to form a complete clamp ring, aligning the bolt slots in the HUF with bolt holes in the appliance.
4. If needed to have a 1/4" thick flange, add the two other half clamp rings
5. Secure clamp rings with bolts. Hardware are not included (by others)
6. For DIS1, DIS2 and DIS4 only, add insulation to fill the gap of the section.
7. For DAS1, DIS1, DIS2 and DIS4, add the Outer Band (BSE).

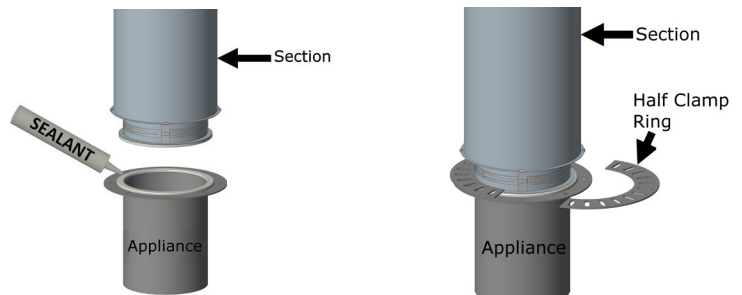

Step 1

Step 2

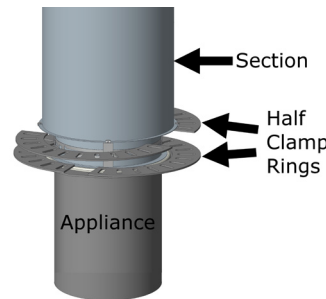

Step 4

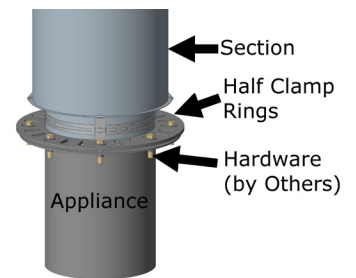

Step 5

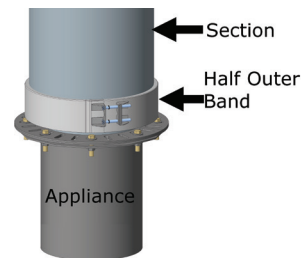

Step 6-7

Figure 79 - Installation on a Flange with bolt pattern

INSTALLATION ON A FLANGE WITHOUT BOLT PATTERN See Figure 80:

1. Apply a continuous bead of sealant to the face of the pipe flange and to the appliance flange.
2. Align the pipe flange with the appliance. Make sure that there is sealant everywhere between both flanges.
3. Position one half clamp ring on the top of the inner wall section flange. Place another clamp ring, but at 90° apart of the first half clamp ring, under the appliance flange.
4. Secure both rings with 2 bolts and nuts (by others).
5. Install the other halves to complete a full ring over and under the flanges.
6. Tighten all nuts and bolts (by others) in an alternating pattern until the pipe is seated firmly between the appliance and the adapter.

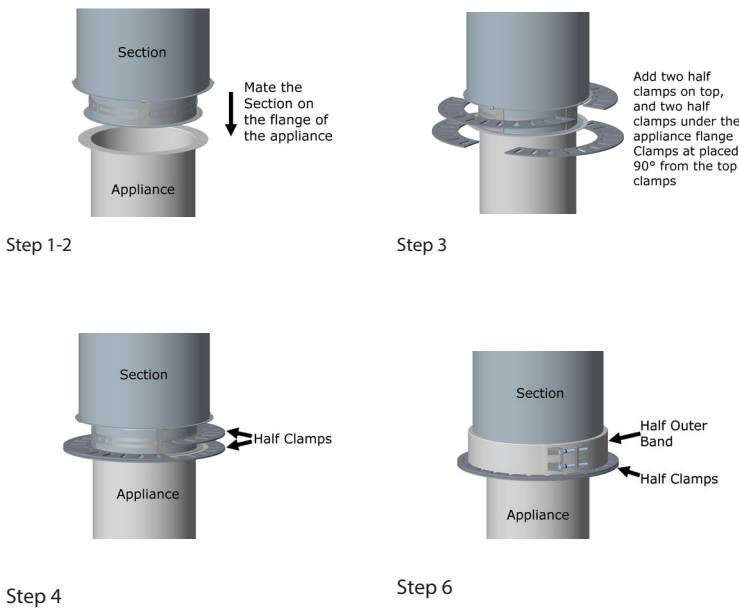

Figure 80 - Installation of an Universal Flange Adaptor (HUF) on an appliance that have a small 1/2" flange (no holes).

DAMPER LENGTH*

DAMPER LENGTH (DAMPLXX)

The Damper Length is a manual (non-automatic) damper used to ensure optimum pressures through an appliance. It will aid in the proper operation and efficiency of the appliance by preventing higher than desired draft readings. It is installed like a regular section (See JOINT ASSEMBLY Section for installation) See Figure 81a and 81b.

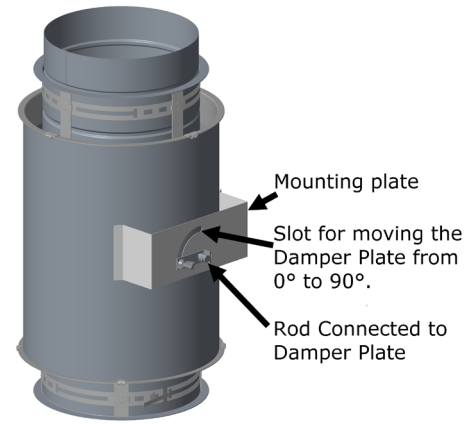

Figure 81a - Damper

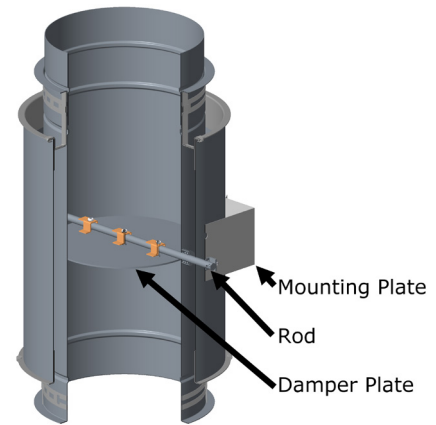

Figure 81b - A quarter section view of a Damper

NOTE: DIAGRAMS & ILLUSTRATIONS ARE NOT TO SCALE.

*NOTE: At present July 2018, UL LLC has no safety standard for these devices, so although they are shown in this document and condoned by Duravent and others, UL has not independently investigated.

SECTION H - GREASE DUCT SPECIFIC COMPONENTS

STRAIGHT SECTIONS

HORIZONTAL DRAIN LENGTH (HDL)

1. Horizontal Drain length is equipped with a 1" (25) NPT nipple, which is attached to the inner flue and extends through the outer casing to provide a path to drain grease, condensate or wash water from the duct. See Figure 82.
2. A dam is attached to the inside of the inner flue adjacent to the nipple to channel the effluent to the drain.
3. The duct drain is intended for use at the end of a horizontal run where access and drainage is needed (See Figure 83).
4. The drain coupling must be connected to a grease trap or approved container (supplied by others).

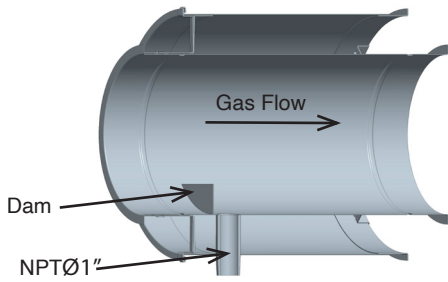

Figure 82 - Horizontal Drain Length

NOZZLE LENGTH (NL)

The nozzle section is used when the duct is required to be equipped with a fire suppression system or washdown is desired.

The nozzle section allows a spray head or nipple to be attached to the duct through a 1" (25) NPT coupling attached to the inner flue.

When the Grease Duct section is in a vertical orientation, the nozzle may be located at the most convenient place. See Figure 84.

NOTE: Local authorities should always be consulted regarding the need for fire protection or washdown systems be installed so that the coupling is at or above the horizontal centerline of the chimney.

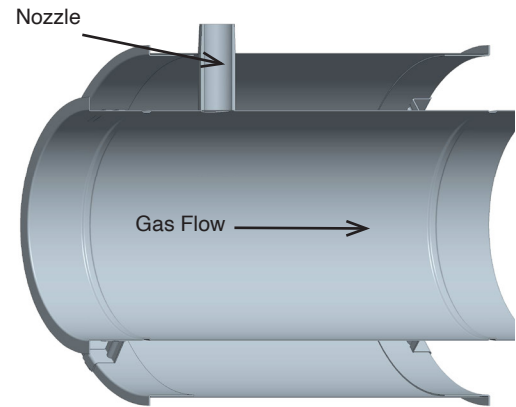

Figure 84 - Nozzle Section

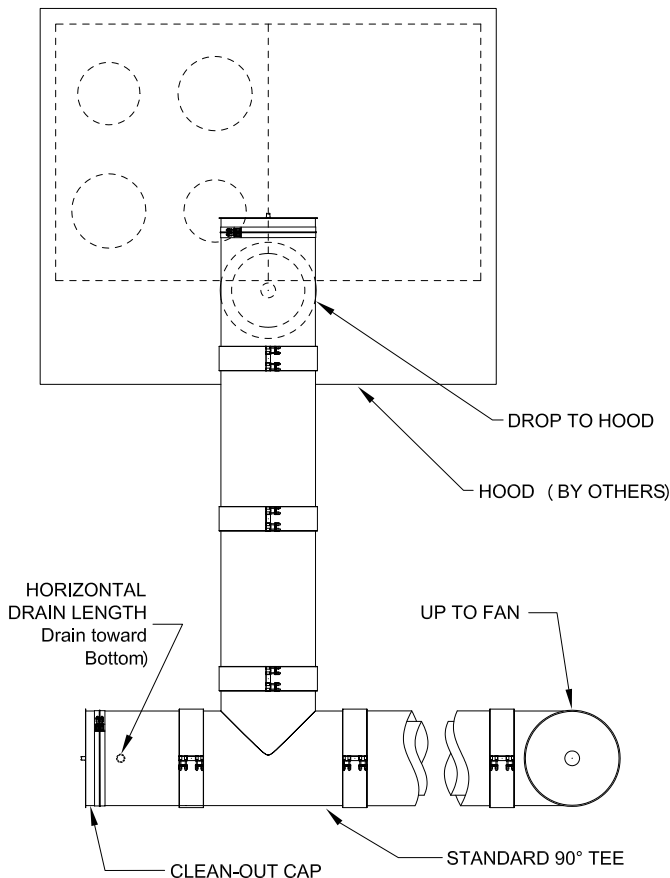

Figure 83 - Horizontal Drain Length typical location (Top View)

ACCESS FOR CLEANING OR INSPECTION

Grease Duct installations require provisions for cleaning the interior of the duct. NFPA 96 clean-out requirements are as follows:

1. A clean-out must be provided at each change of direction except where the entire length of the duct can be inspected and cleaned from either the hood or the discharge end.
2. On horizontal duct runs, at least one (1) 20" (508) diameter opening must be provided. Where the duct is smaller than 20" (610) diameter, openings large enough to permit cleaning must be provided at intervals of not more than 12' (3.66m).
3. Openings may be at the side or the top of the duct whichever is more accessible. When the opening is on the side of the duct, the lower edge of the opening must be at least 1-1/2" (38) above the bottom of the duct. For Grease Duct, this is accomplished by the use of the 90° Tee with the dam option (T90D#) with a Tee Cap (TC) or a No Tool Tee Cap (NTTC).
4. On vertical ducts where personnel entry is possible, access must be from the top of the riser. Where personnel entry is not possible, access for cleaning shall be provided on each floor.

NOTE: ACCESS REQUIREMENTS ARE SUBJECT TO CHANGE IN ACCORDANCE WITH LOCAL CODE. LOCAL AUTHORITIES SHOULD BE CONSULTED FOR EXACT REQUIREMENTS.

NO TOOL INLINE ACCESS DOOR (ADL24 OR ADL36)

The No Tool Inline Access Door is offered as an alternative to the TC to allow for complete access for inspection and cleaning without the use of tools. Can be installed on vertical or horizontal runs. When installed on horizontal runs, the opening must be above the centerline of the duct. The ADL24 and ADL36 comply with requirements of NFPA96 and the International Mechanical Code for accessibility. The No-Tool Access Door is all factory assembled. See Figure 85.



Figure 85: No Tool Inline Access Door ADL24 or ADL36

REMOVAL FOR INSPECTION

NOTE: For the Model DCL, go to step 4.

- 1- Unscrew the 6 or 10 wing screws (based on pipe diameters) with your hands and set them in a safe place during the inspection.
- 2- Remove the outer door from the outer wall of the duct and set it in a safe place during the inspection.
- 3- Remove the insulation pad and set it in a safe place during the inspection. See Figure 86.

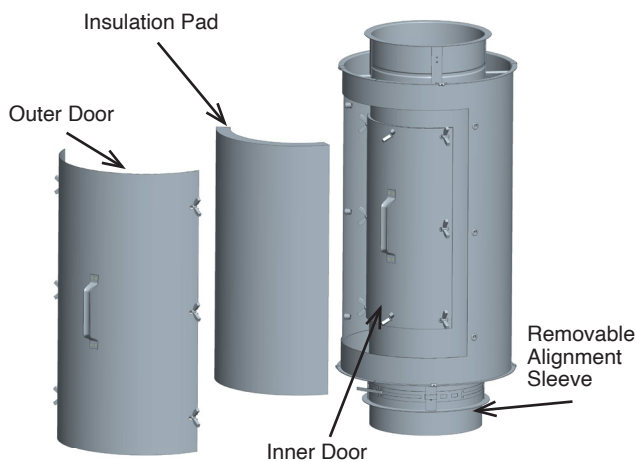

Figure 86: Step 1-3 of Removal for Inspection for the ADL

- 4- Unscrew the 8 or 12 wing screws (based on pipe diameters) and set them in a safe place.
- 5- Remove the Inner cover and set it in a safe place. See Figure 87.

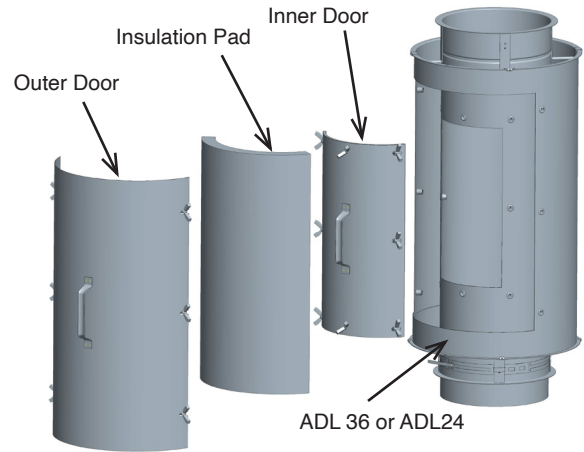

Figure 87: Step 4-5 of Removal for Inspection for the ADL

- 6- Inspect the ceramic gasket (white) and the silicone gasket (gray) attached on the inside of the Inner door for any damage (see Figure 88). If any damages, you must replace one or both gaskets. See Figure 88.

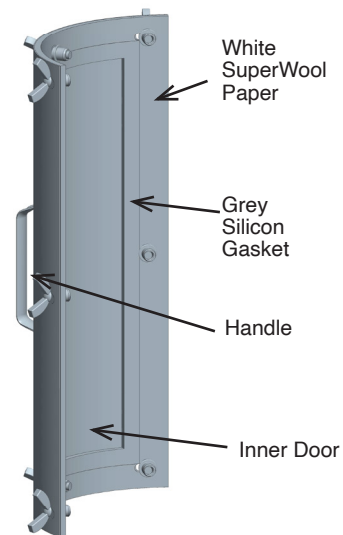

Figure 88: Step 6 of Removal for Inspection for the ADL

REPLACEMENT OF THE ACCESS DOOR:

- 1- Replace the Inner door on the duct over the access hole.
- 2- To make sure the door is properly aligned and sealed, install only the top and lower central wing screw and tighten both.
- 3- Make sure that the doors are well aligned with all the rivnuts.
- 4- Reinstall the other 8 to 12 wing screws (based on pipe diameters) left and tighten adequately.
- 5- (DIS3Z Model Only) Replace the insulation pillows over the inner door.
- 6- Replace the outer door.
- 7- Reinstall the 6 to 10 (based on pipe diameters) wing screws and tighten them with your hands.

DRAIN BUCKET (DB)

The Drain Bucket consists of a 8 1/2" long duct section with an installed cap. It is intended for use as a drain point and access at the base of the duct riser. The drain nipple must be attached to a grease trap or approved container (supplied by others).

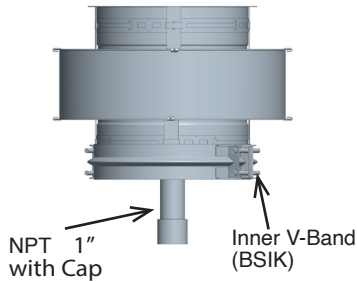

Figure 89: Drain Bucket (DB)

NO TOOL ACCESS TEE CAP (NTTC)

The No-Tool Access Tee Cap (NTTC) provides no tool access for inspection and cleaning of the grease duct (See Figure 90).

NOTE: Use only on horizontal duct runs.

This part list includes:

- 1 x No Tool Cap Kit, composed of;
 - 1 x No-Tool Cap
 - 1 x No-Tool Dam (with 6x to 20x rivnuts, based on pipe diameters)
 - 6x to 20x Wing Nuts (based on pipe diameter)
 - 1 x V-Band (BSI)
 - 1 x AES Wool Gasket

The next items are for the Grease Duct only

- 1 x No-Tool Outer Casing with 4 to 8 latches (based on pipe diameters)
- 3 x Insulation Round Pad
- 1 x Insulation Band

The No-Tool Cap kit is factory installed to the No-Tool Dam with the use of several wing nuts and Inserts.

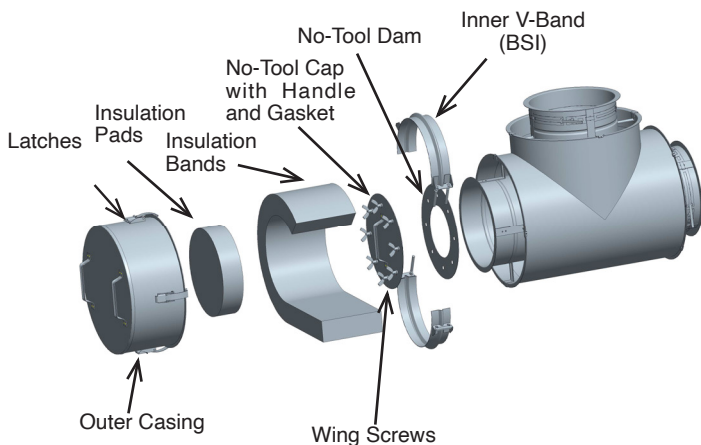

Figure 90- No Tool Tee Cap (NTTC)

INSTALLATION PROCEDURE

- 1- Apply sealant to duct flue flange and the No-Tool Cap Kit, about a 3/8" bead all around the Kit.
- 2- Use the inner V-Band (BSI) to secure the No-Tool Cap Kit to the flange of the 90° Tee (T90, not included) as specified in the JOINT ASSEMBLY section. See Figure 91.

NOTE: Be sure the handle of the NT-Cap faces outward as shown.

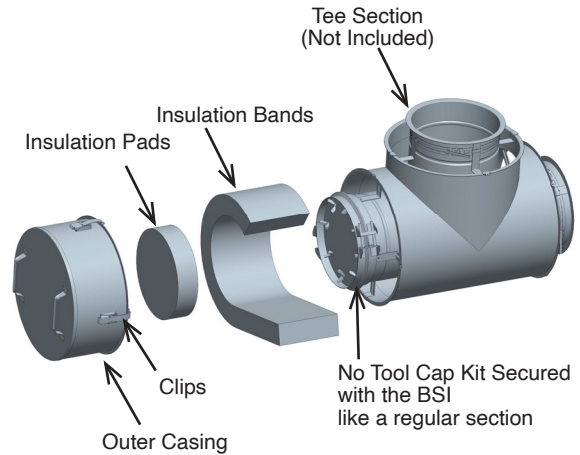

Figure 91- Step 1 & 2 for the No-Tool Tee Cap Installation

- 3- Install the insulation Bands inside the outer casing. Make sure that it is well placed against the inner side of the wall of the casing.

NOTE: Do not cut the extra height of the insulations. The insulation bands has to be higher than the outer casing wall, so it can insulate up to the spacers between both walls of the Tee Section.

- 4- Then add the insulation Pads at the bottom of the casing, in the middle of the insulation wrap. See Figure 92.

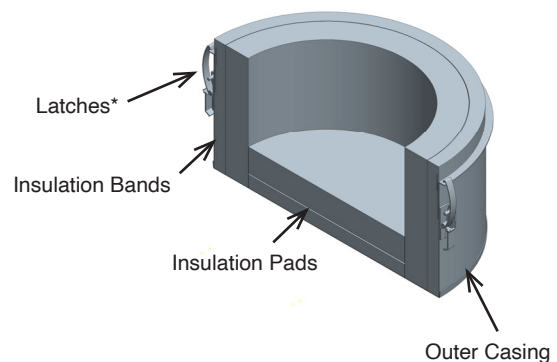

Figure 92- No-Tool Tee Cap Installation Step 3-4

TEES

90° TEE (T90) AND GREASE TEE WITH DAM (T90D#)

The 90° Tee is generally used to connect horizontal connectors into a vertical section as well as a drain or inspection fittings.

To comply with the NFPA 96 requirements, the T90D# is comprised of a T90 equipped with a 1 1/2" wide circular "donut" welded in place (serve as a dam) at any access port and must be closed with a Tee Cap (TC) or a No Tool Tee Cap (NTTC). The location of the access port in the Tee is dependent on the orientation of the tee in the final installation. Access port location is coded as shown in Figure 93a and Figure 93b for the two options.

NOTE: For the maximum height of grease duct above a based supported Tee, see Table 4 in the SUPPORT METHODS AND HEIGHT LIMITS section.

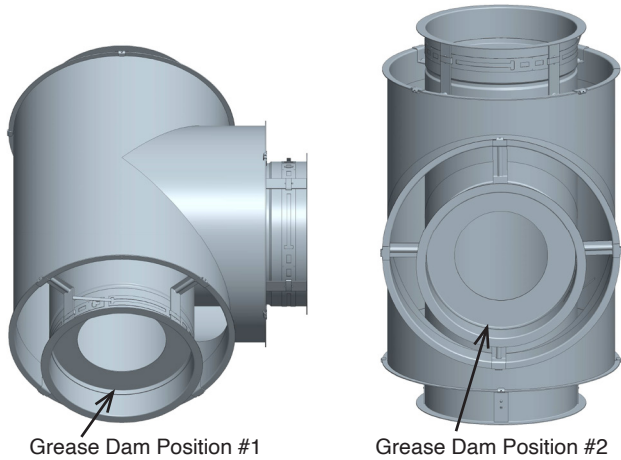

Figure 93a - Grease Dam Position #1 Figure 93b - Grease Dam Position #2

90° TEE WITH NOZZLE (T90N)

Like the Nozzle Length (NL), the 90° Tee with Nozzle T90N is used when the duct is required to be equipped with a fire suppression system or wash down is desired.

The T90N section allows a spray head or nipple to be attached to the duct through a 1" (25) NPT coupling attached to the inner flue.

When the grease Duct section is in a vertical orientation, the nozzle may be located at the most convenient place. See Figure 94.

NOTE: Local authorities should always be consulted regarding the need for fire protection or wash down systems be installed so that the Nozzle is at or above the horizontal centerline of the grease duct.

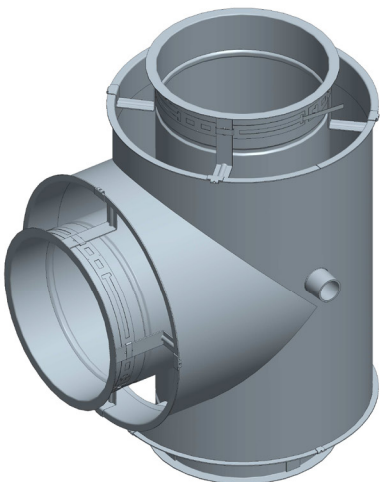

Figure 94 - 90° Tee with Nozzle (T90N)

Y-Tee (TY)

1. The Tee Y (TY) is very useful where the grease duct must be accessed for clean-out and inspection purposes. See Figure 95.
2. It can be used in place of the Tee 90 (T90) and provides excellent access clearance for clean-outs.
3. Clean-outs must be located at all direction changes in the grease ductwork.
4. Installation is the same as standard tee.

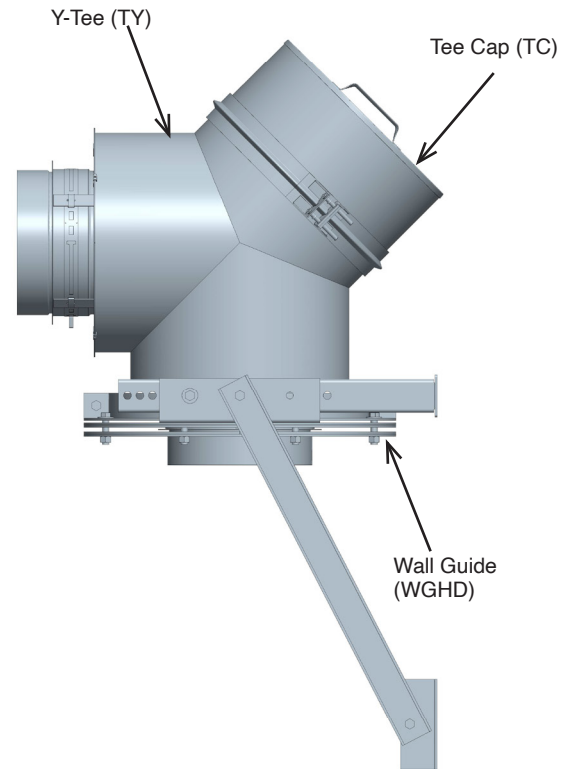

Figure 95 - Installation of a Y-Tee (TY)

ADAPTERS

ROUND FLANGED HOOD ADAPTER (RFHA)

The Round Flanged Hood Adapter is used to connect the first duct section to hood. The adapter is to be welded to the hood connection (See Figure 96).

This adaptor is provided with

- One Inner V-Band (BSI)
- One Outer Band (BSE)
- 6" wide Insulation bands

See Figure 96 for an example of installation.

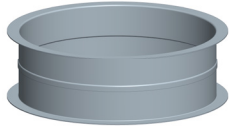
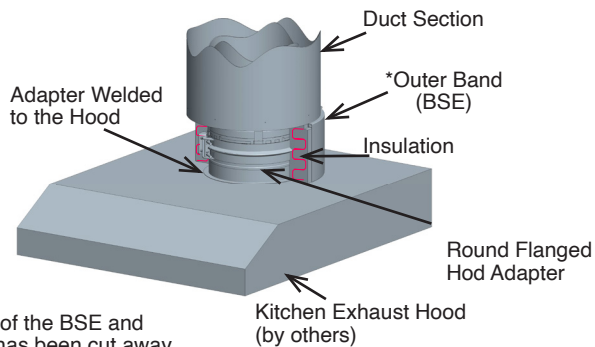

Figure 96a: Round Flanged Hood Adapter (RFHA)



* A portion of the BSE and Insulation has been cut away for a better view of the assembly

Figure 96b: Round Flanged Hood Adapter Installed



Figure 97: Square To Round Adapter (STR)

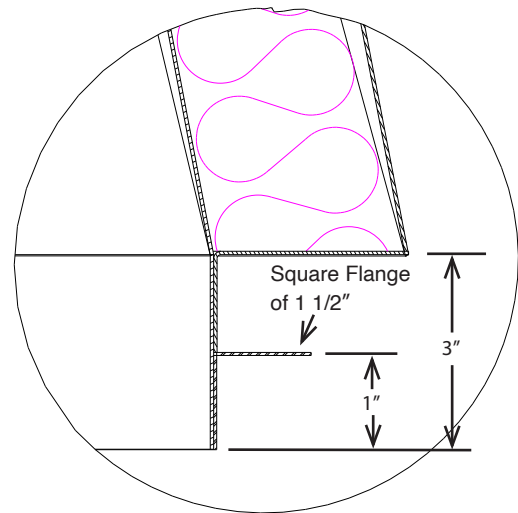

Figure 98a: Option 1 for the STR and ESTR

SQUARE HOOD CONNECTION

When a kitchen exhaust hood is equipped with a square or rectangular collar, a Square To Round adapter is needed to connect the round duct to the hood. The Square to Round is connected to hood collar by means of a lap weld.

SQUARE TO ROUND ADAPTER (STR)

The Square To Round is used to connect a hood equipped with a square or rectangular collar to a round duct (See Figure 97). Two different options for connection may be used for the square end fitting:

Option 1: A flange at 1" from the square end. The outside dimensions of the square end of the STR are slightly smaller than the hood collar. It will fit inside the collar (making an overlap of 1") and the flange of the STR will sit on hood. It will be connected by means of lap weld. See Figure 98a.

Option 2: A Flange at the square end to be used for a bolted or welded connection in accordance with NFPA 96. See Figure 98b.

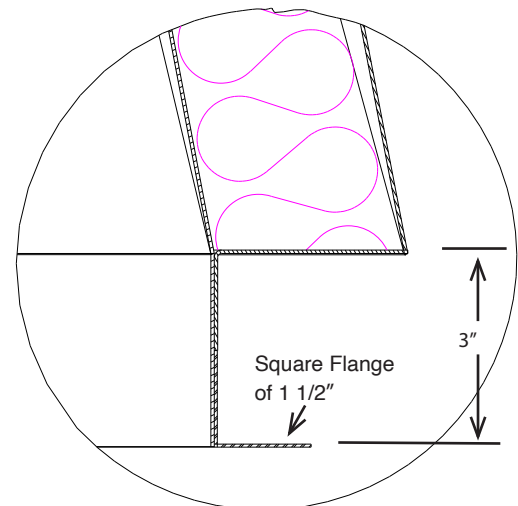

Figure 98b: Option 2 for the STR and ESTR

ECCENTRIC SQUARE TO ROUND ADAPTER (ESTR)

ESTR is similar to a STR except the round collar is offset from center of the square collar. See Figure 99.



Figure 99: Eccentric Square To Round (ESTR)

When ordering a square to round adaptor for connection to kitchen exhaust hoods, the following information must be specified:

- 1- The exact size of the square or rectangular end.
- 2- Options for the square end (See Figure 98a and Figure 98b)
- 3- Any flanging requirements (typically flange is 1-1/2" wide)
- 4- Diameter of the round end (i.e. size of Duravent Grease Duct series)
- 5- Overall length - 20" standard.

NOTE: Custom requirements (flange thickness, bolt pattern, custom length, unusual square dimensions, etc) will be analyzed by our engineering department.

DUCT TRANSITION (GREASE DUCT APPLICATION ONLY)

As a general rule, grease duct systems are intended to be installed as complete systems without the use of other manufactured or generic components. However, Duravent recognizes that in some instances due to space limitations at certain locations within a system the need to transition from Grease Duct to rectangular welded duct and back to Grease Duct may exist. See Figure 100 and Figure 101 for typical installations.

The square to round adapter is very useful for interconnecting round grease duct to rectangular welded duct where necessary due to space limitations or for breaching larger rectangular ducts used as a central shaft. In such cases, it is permissible to interconnect or transition parts from Duravent grease duct to a code compliant, rectangular welded steel duct system (by others) and back again. When such situations occur, Duravent will fabricate and supply a fully welded round to rectangular transition that is code compliant single wall grease duct (fabricated of a minimum 0.043" thick stainless steel) that is specifically designed to provide proper drain slope for the transition (like an Eccentric Square to Round would allowed doing). These transitions provide direct connection to series grease duct at the round end and allow for a field welded connection to code complaint welded steel grease duct at the rectangular end.

To comply with national codes, these transitions are to be fully enclosed in same manner as the welded grease duct that it is connected to. Such enclosure systems may be either a field applied wrap system or a separate fire protective shaft enclosure with an appropriate fire resistance rating. When installed with Grease Ducts, the fire rated enclosure system must extend up to the adjacent duct section. The transition to flexible wrap enclosure is approved by Underwriters Laboratories provided the enclosure material is UL Classified per ASTM E2336, classified for use as a grease duct assembly per UL CAT. HNKT (See Batts and Blankets CAT. HNMF) or Intertek Design No. FRD 120-01 and is equal or greater than the fire rating of Grease Duct.

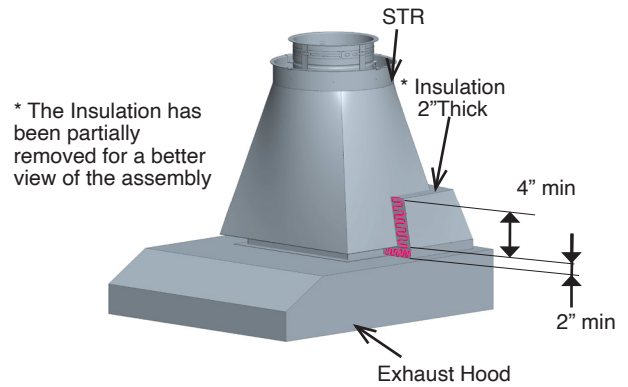

Figure 100: STR Transition from Exhaust Hood to Grease Duct

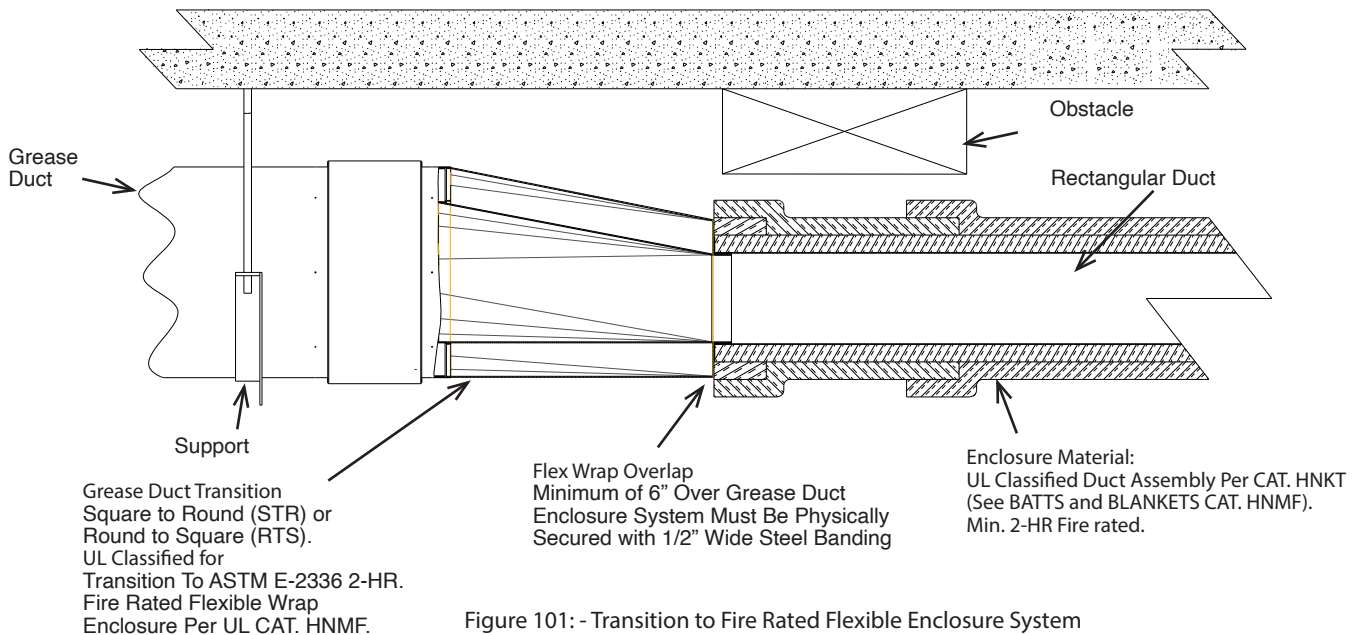

Figure 101: - Transition to Fire Rated Flexible Enclosure System

SECTION I - GREASE DUCT LOCATION OF SUPPORTS

Supports can be used in different combinations to secure grease duct in place. See Figure 2, 3, and 4 for typical support and guide locations.

ADJUSTABLE AND VARIABLE LENGTH SUPPORT

To prevent the LV or LA from sagging, it is recommended that the duct section adjacent to a LV or LA is supported or guided. See Figure 102 for typical support locations for Adjustable and Variable Length.

When necessary, properly guide an adjustable length by installing a Heavy Duty Wall Guide (WGHD) or any supports immediately below duct join on adjacent section.

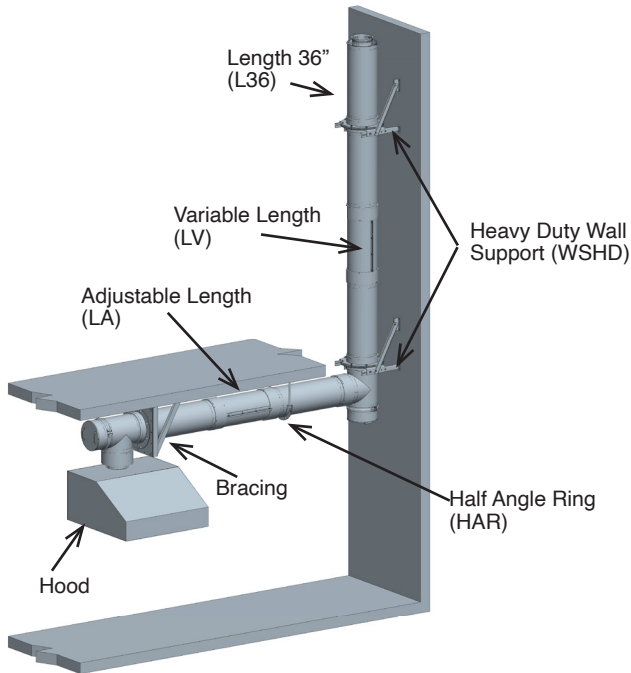

Figure 102: Typical Installation locations for the Variable and Adjustable Lengths

NOTE: Both LA and LV overlapping joints are not intended to support any weight in the vertical position. The inlet and outlet ends must each be supported.

TEE SUPPORT

The Tees must be supported properly to protect them from bending. It can be done by means of Anchor Plate (AP), Anchor Plate with Length (APL) or Heavy Duty Wall Support (WSHD).

When that multiple tees (90° Tees, 45° Tees or Lateral Tees) are used to Connect multiple hoods, it is important to make provisions for expansion of the manifold. Adjustable length should be installed between Tees. See Figure 103.

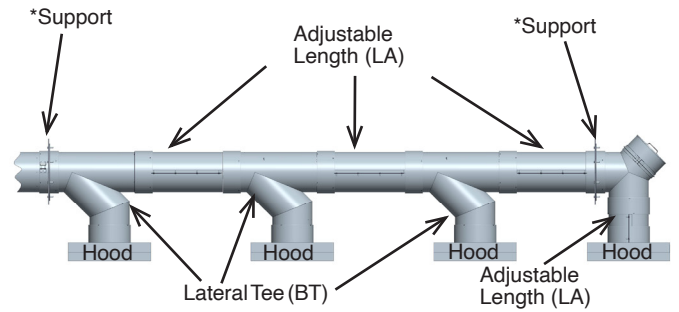

*Framework and Bracing are not shown in this image

Figure 103: Support for Multiple Tees

When a tee is used at the base of the riser, the preferred location for support is above the Tee, thus suspending the Tee. See Figure 104

An Heavy Duty Wall Support (WSHD), an Anchor Plate (AP) or an Anchor Plate with length (APL) can be used to support the TEE.

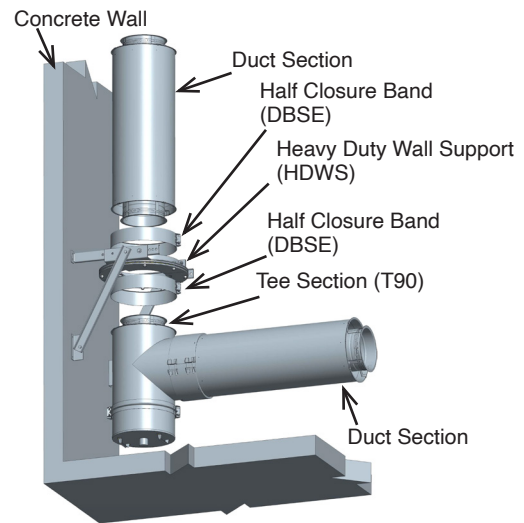

Figure 104: Suspended Tee Support

NOTE: In the case of an AP, Flange joint of duct and Tee are to be secured in place between the Clamp Rings. If it is not possible to suspend the Tee, it may be supported with a base (a structural steel stand).

When a base is necessary, access to the Drain Bucket or the Drain Tee Cap (DTC) may be hindered. A DB or a DTC should be used under the Tee to allow access for cleaning and inspection into the grease duct.

ELBOW SUPPORT

Elbows are to be supported on one end with either an Anchor Plate (AP), an Anchor Plate with Length (APL), or a Heavy Duty Wall Support (WSHD). See Figure 105 for an example with an AP and Figure 106 for an example with a (WSHD).

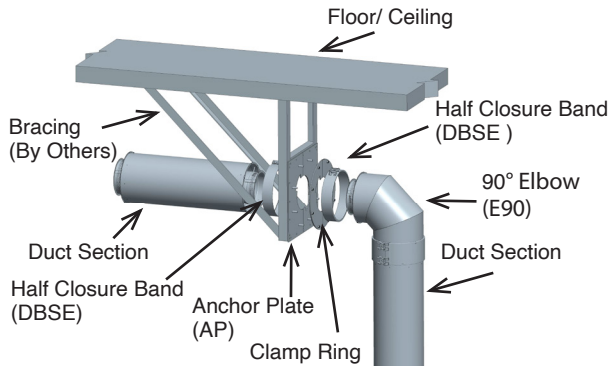

Figure 105: Elbow with an Anchor Plate (AP)

NOTE: In the case of an AP, flange joint of duct and elbow are to be secured in place between the Clamp Ring and square plate Support.

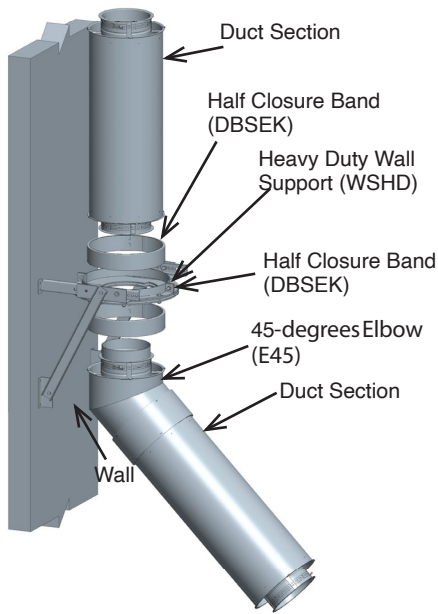

Figure 106: Elbow with an Heavy Duty Wall Support (HDWS)

NOTE: Flange joint of duct and elbow are to be secured in place between the Clamp Rings

THROUGH FIRE RATED FLOOR/CEILING SUPPORT (DIS3Z ONLY)

Supports for ducts that penetrate a fire-resistant floor are to be positioned on the top side of the floor. Include supports as per the height limits in Table 5 and use either an Anchor Plate (AP) or an Anchor Plate with Length (APL) installed above structural framing members as shown in Figure 107. Where a transition from horizontal to vertical occurs beneath a floor / ceiling assembly, support the horizontal portion beneath the floor using Half Angle Rings (HAR) with a minimum 1/2" dia. threaded rod. Install one HAR on the section adjacent to the Tee and include additional Half Angle Rings (or other, appropriate supports) for the horizontal portion of the system in accordance with Table 7.

NOTE: Supports required for use in the vicinity of a TPFK must be installed on the top side of the floor penetration. See THROUGH PENETRATION FIRESTOP section.

NOTE: Hole cut in floor shall be 2" greater than the outer wall of the grease duct.

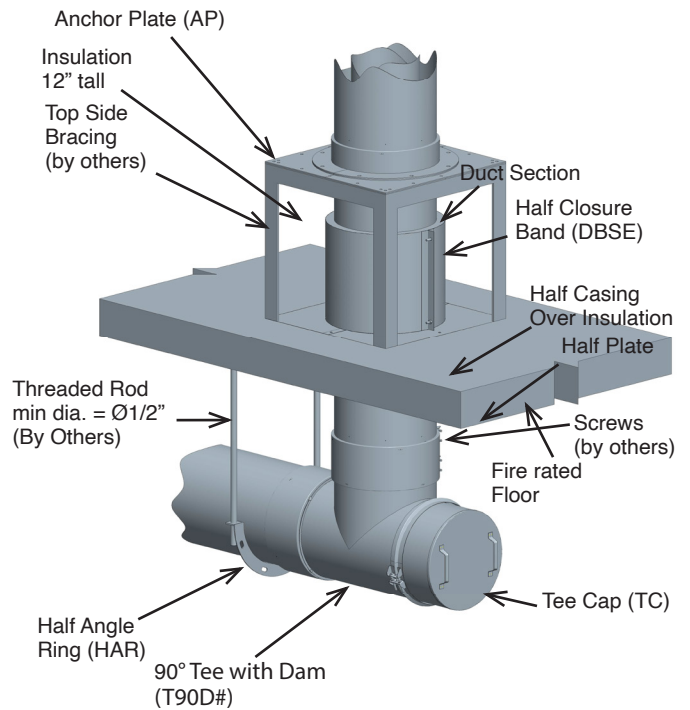

Figure 107: Supports for Duct passing through a fire-rated Floor-Ceiling (DIS3Z only)

NOTE: In the case of an AP, the flange joint of duct penetration floor and adjacent duct are to be secure in place between the Clamp Ring and the Square Support Plate.

THROUGH FIRE-RATED WALL SUPPORT (DIS3Z ONLY)

Ducts that penetrate a fire-resistance wall (up to 2hr fire-rated) have to be supported on both side of the wall. It can either be supported by bracing a HAR, a AP or APL. See Figure 108.

NOTE: Duct Support is used in addition of two Through Penetration Firestop Kits (TPFK). The TPFK must be installed on both side of the wall.

NOTE: Hole cut in floor shall be 2" greater than the outer wall of the grease duct.

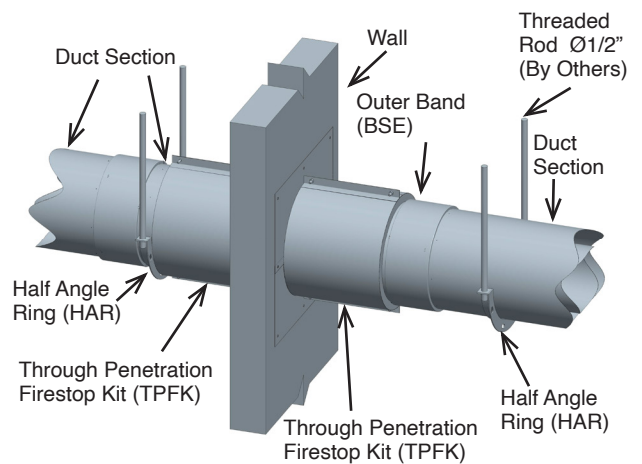

Figure 108: Supports for duct through fire-rated wall (DIS3Z only)

SECTION J - GREASE DUCT FIRE-RATED FLOOR, ROOF AND WALL PENETRATION (DIS3Z ONLY)

FLOOR AND WALL PENETRATION

THROUGH PENETRATION FIRESTOP KIT (TPFK)

Fire Resistance Rating: 2 Hour (F & T)

Whenever the DIS3Z grease duct passes through a fire rated wall or floor, a TPFK must be used to retain the fire rating.

NOTE:- For Floor Penetration, use one TPFK. See Figure 109 and Figure 107.
- For Wall Penetration, use two TPFK's. See Figure 111 and Figure 108.

One Kit contents:

- 2 x Split Closure band
- 2 x Half Cover Plate
- 1 x 12" tall Fiber Insulation Strip (6 pcf)
- 1 x 3 1/2" tall Fiber Insulation Strip (6 pcf)

NOTE: Must use S-TPFS (SpecSeal Triple S Intumescent Firestop Sealant - SSS100), but not included in the kit. The Table 12 referstotheexpectednumberoftubeofS-TPFSforeachmodels:

Inner Duct Diameter	Number of tube per hole
5	2 1/4
6	2 1/2
7	2 3/4
8	2 3/4
9	3
10	3 1/4
11	3 1/4
12	3 1/2
13	3 3/4
14	3 3/4
16	4 1/4
18	4 1/2
20	5
22	5 1/4
24	5 1/2
26	6
28	6 1/4
30	6 1/2
32	7
34	7 1/4
36	7 3/4

INSTALLATION PROCEDURE

1. Cut a circular hole into the fire rated floor or wall that is 2" greater in diameter than the OD of the duct.
2. Center the grease duct within the hole and support to maintain position.
3. Tightly pack the 1" gap between the outer wall of the duct and the hole with the 3 1/2" wide 6 pcf fiber insulation strip provided. This insulation must encircle the outer wall of the duct and fill the gap to within 1/2" of both surfaces.
4. Apply a minimum 1/2" depth of S-TPFS (SSS100 from SpecSeal), flush with both surfaces of the wall. See Figure 109.
5. Install the two piece rectangular Cover Plate. The two piece rectangular Cover Plate is designed to fit over the firestop sealant and around the outer wall of the duct. There will be a nominal 1/4" gap around the pipe and the two parts of the plate must overlap each other for a minimum of 1". Secure in place with appropriate hardware (by others).
6. Wrap a 12" wide strip of the fiber insulation around the grease duct. The insulation must butt up to the cover plate and outer wall of the duct. See Figure 110.

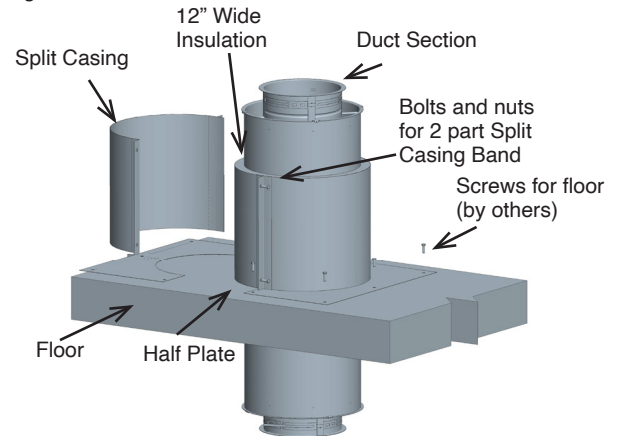

Figure 110: Step 1-2-3-4-5-6 of TPFK

7. Secure the insulation in place with the two part split closure band using the hardware provided.

NOTE: The cover plates, wrap insulation and split closure bands are installed on the top surface of a floor penetration and on both surfaces of a wall penetration. See Figure 111 for the penetration through a wall.

CAUTION: Do not use the Adjustable Length with the Through Penetration Firestop.

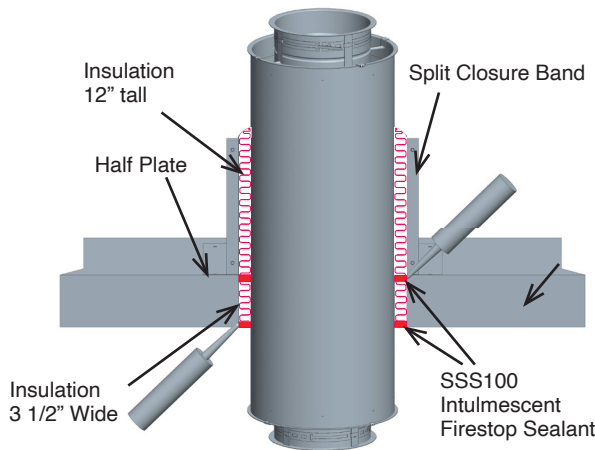

Figure 109: Through Penetration Firestop fire-rated Floor Penetration (DIS3Z only)

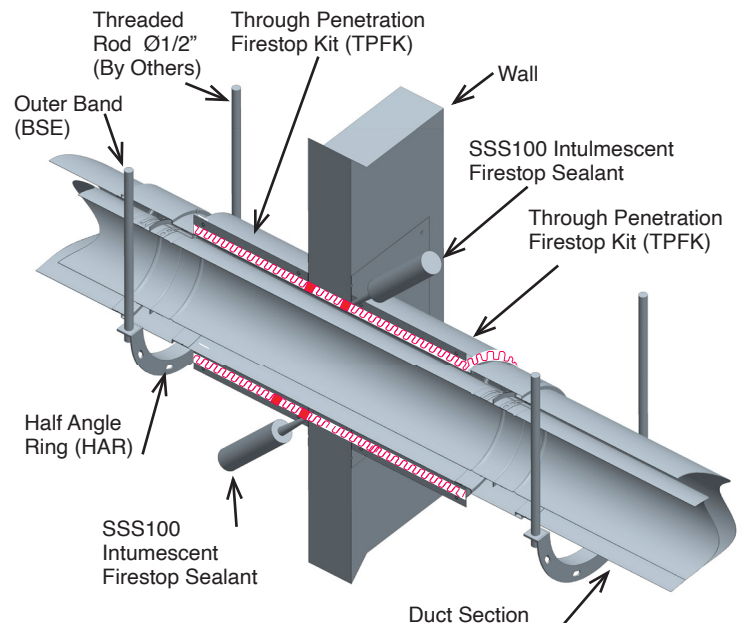

Figure 111: TPFK Assembled Through a fire-rated Wall (DIS3Z only)

SECTION K - GREASE DUCT WALL, FLOOR AND ROOF PENETRATION, GUYING AND BRACING.

A chimney that has to penetrate through a floor, roof or wall made of COMBUSTIBLE materials, must use a Roof Thimble (RT) or a Wall Thimble (WT). The minimum air space clearance between the outer wall of the chimney and the combustible material of the roof / floor / wall listed in the Table 2 must always be respected when using a Roof Thimble (RT) or a Wall Thimble (WT). See Table 4 for dimensions of the opening in the floor / wall to respect the clearances.

ROOF THIMBLE (RT)

The Roof Thimble (RT) is used when a chimney passes through a floor or roof made of combustible materials. The specific clearances in Table 2 must always be respected. See Table 4 for dimensions of the opening in the floor / wall to respect the air space clearances.

The Roof Thimble is made of a square plate with a radiation shield on it, to protect the combustible material inside the hole of the floor/ceiling. Four angles are added on the hole side of plate to be sure it won't fit if the hole in the floor doesn't respect the clearance. See Figure 112.

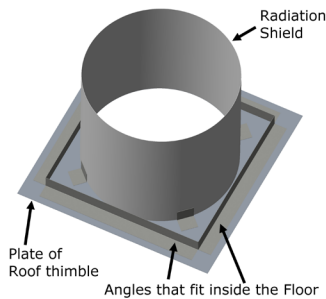

Figure 112: Roof Thimble (RT)

The radiant shield may need to be trimmed to fit the height of the floor. The RT is designed to be installed on a flat roof. They may be installed on a pitch roof if a curb is installed to provide a flat surface. Guides or Supports must be used either on top or under the floor/roof/ceiling to ensure that the chimney is well centered in the Roof Thimble (RT).

When a Flashing (F) and a Storm Collar (SC) are used on top of the roof, use the exterior sealant S-375 to seal the Storm Collar (SC) on the outer casing with the outer joint sealant.

Do not installed a chimney joint or a expansion length in the roof/floor space.

Installation:

1. Cut opening to dimensions specify in Table 4.
2. The plate of the Roof Thimble must be installed under the floor / ceiling, with angles and radiation shield inside the hole.
3. Slide DAS1, DIS1, DIS2, or DIS4 chimney through the Roof Thimble
4. Install guide under the floor.

Note: When there is thermal expansion, make sure to have the expansion distance calculated (with the expansion formula on page 5) between the guide and an outer band (BSE) of a joint section.

5. Install a Flashing (F) on the top of the floor over the chimney , screw it and seal it with the outer sealant S-375.
6. Add the Storm Collar (SC)
7. Seal with the outer sealant S-375 the Storm Collar (SC) on the outer wall of the section.

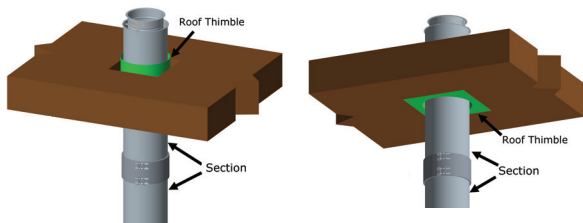

Figure 113: Roof Thimble installed

WALL THIMBLE (WT)

Wall Thimble (WT) is used when a chimney passes through a wall made of combustible materials.

The part consist of a roof thimble female half and a male roof thimble half that slide in each other to adjust wall thickness from 8" to 12". The specific clearances in Table 1 must always be respected. See Table 4 for dimensions of the hole opening in the wall to respect the air space clearance.

This assembly is made of two parts. See Figure 114.

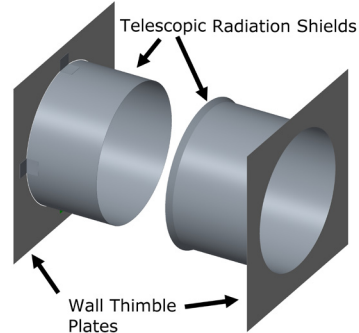

Figure 114: Wall Thimble (WT)

Installation:

1. Cut opening in the wall to dimension indicated in Table 4.
2. On one side of the wall, slide the Female half in the opening and fix it to the wall with screws.
3. On the other side of the wall, slide the male half into the opening and fix it to the wall with screws.

NOTE: A minimum overlap of 2" must be made between the male half into the female half.

4. Insert the chimney through the opening of the Wall Thimble (WT).
5. The chimney must be well supported or guided on both side of the wall to prevent any load or offset of the chimney in the Wall Thimble.

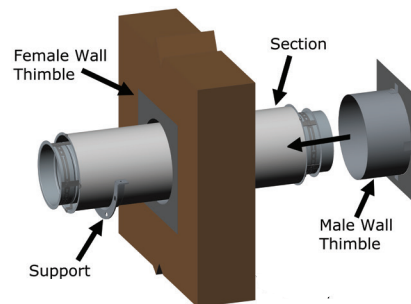

Figure 115: Supports for Chimney passing through a Wall

THROUGH WALL SUPPORT

Chimney that penetrate wall have to be supported at least on one side of the wall, supporting the section that penetrates through the wall. It can either be supported by bracing a Half angle Ring (HAR), Anchor Plate (AP), or Anchor Plate Length (APL) See Figure 116.

NOTE: Refer to Table 4 for minimum opening in combustible material.

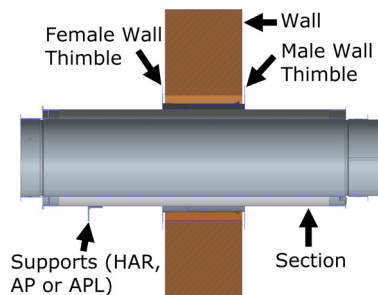

Figure 116: Supports for Chimney passing through a Wall

SECTION L - GREASE DUCT TERMINATION

FAN ADAPTER (FAN)

1. The fan adaptor is designed to connect to an up blast fan (supplied by others) mounted on a roof curb (supplied by others).
2. When connected to an up blast fan, the plate mounts on top of the fan curb which supports the fan housing. See Figure 117.
3. The plate may be positioned off center within the curb provided that minimum clearance to combustibles is maintained.
4. In the event that the plate is positioned off center, trim off excess plate material to allow fan placement.
5. Secure the plate to the curb a minimum of three (3) places per side with minimum #8 x 1-1/4" wood screws. You will have to drill holes in the plate.
6. The fan housing is set on top of the plate and sealed using S-650 sealant or an approved gasket supplied by the fan manufacturer.
7. Specify the grease duct diameter and outside curb dimensions when ordering the fan adaptor plate.
8. The fan adaptor plate can be used as a vertical support. The maximum height of grease duct supported by the fan adaptor plate is 10' for all diameters.

WARNING: DO NOT EXCEED THE MAXIMUM LOAD LIMIT OF THE ROOF CURB OR THE ROOF.

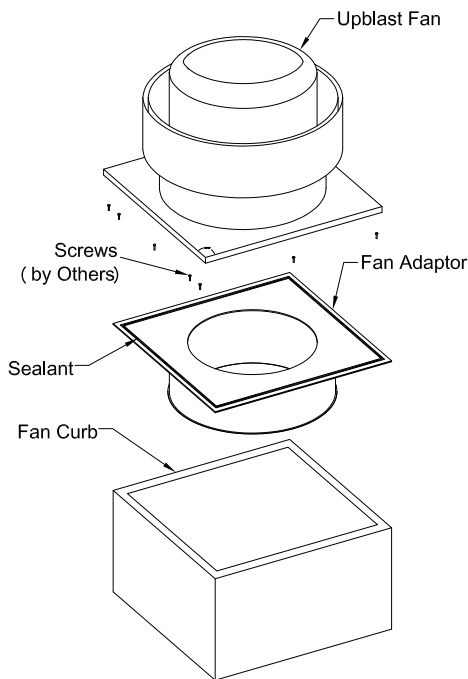

Figure 117: Fan Adapter

SECTION M - GREASE DUCT MAINTENANCE

1. Grease duct is required by NFPA 96 and many local building codes to be inspected and cleaned if necessary at specific intervals.
2. Duravent Grease Duct must be inspected and cleaned in accordance with local requirements. It requires no additional internal maintenance.
3. Duravent recommends that grease containers connected to drainage points be emptied and washed out daily or more often, if necessary. If needed, the drain nipples should be checked and cleaned whenever the containers are emptied.
4. Where the duct is installed outside the building, the Galvalum steel outer casing must be primed and painted. The paint surface should be maintained regularly to prevent possible deterioration of the casing surface. The use of stainless steel outer casing negates the need for painting.

SECTION N - GREASE DUCT & WOOD OVEN

CREOSOTE AND SOOT - FORMATION AND NEED REMOVAL

When wood is burned slowly, it produces tar and organic vapors which combines with expelled moisture to form creosote, the creosote vapors condense in the relative cool grease duct of a slow burning fire. As results, creosote residue accumulates on the duct. If ignited, this creosote and grease-laden vapor make an extremely hot fire. For this reason the duct should be inspected monthly to determine if creosote or soot has accumulated, it should be removed to reduce risk of fire.

A licensed or qualified grease duct cleaner should be contacted to clean the duct. Contact local building or fire officials about restrictions and installation inspection in your area. Adequate clearance is required around cleanouts to assure accessibility for removal of caps and products accumulated within the grease duct.

SECTION O - SAMPLE DRAWINGS

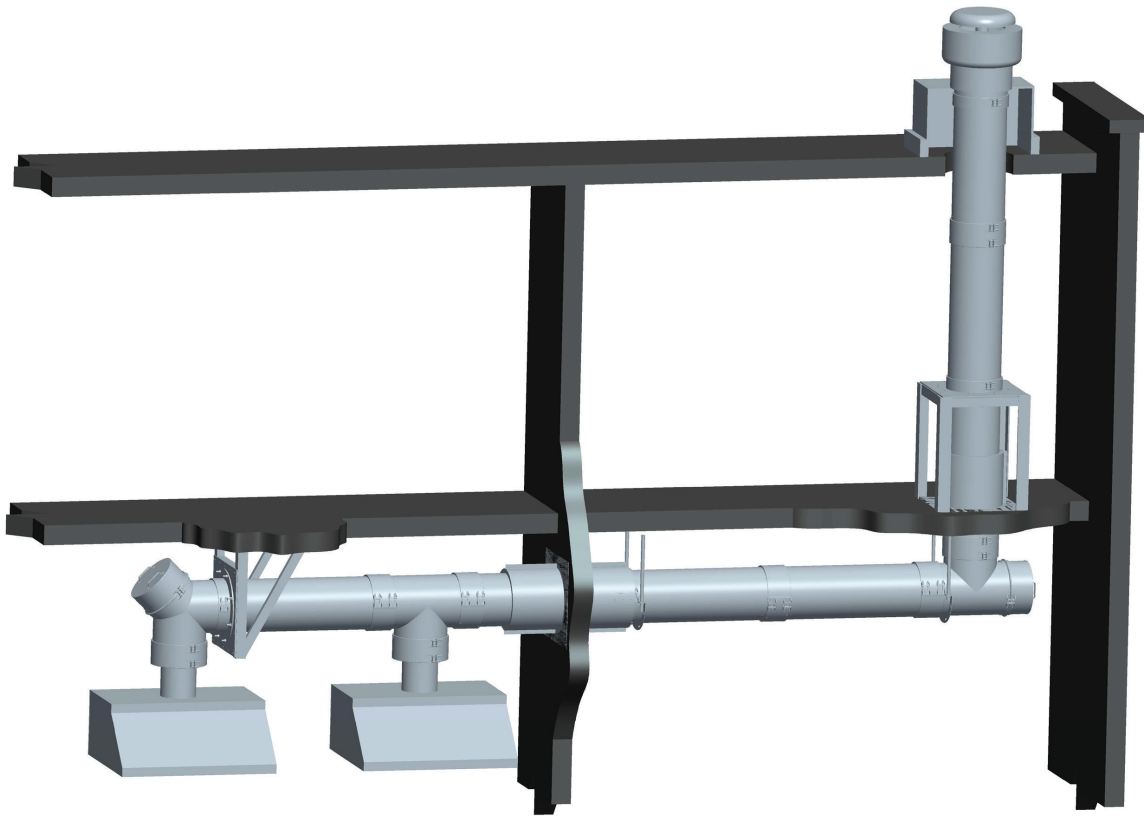

Figure 82 - Sample installation for Grease Duct

NOTE: DIAGRAMS & ILLUSTRATIONS ARE NOT TO SCALE.

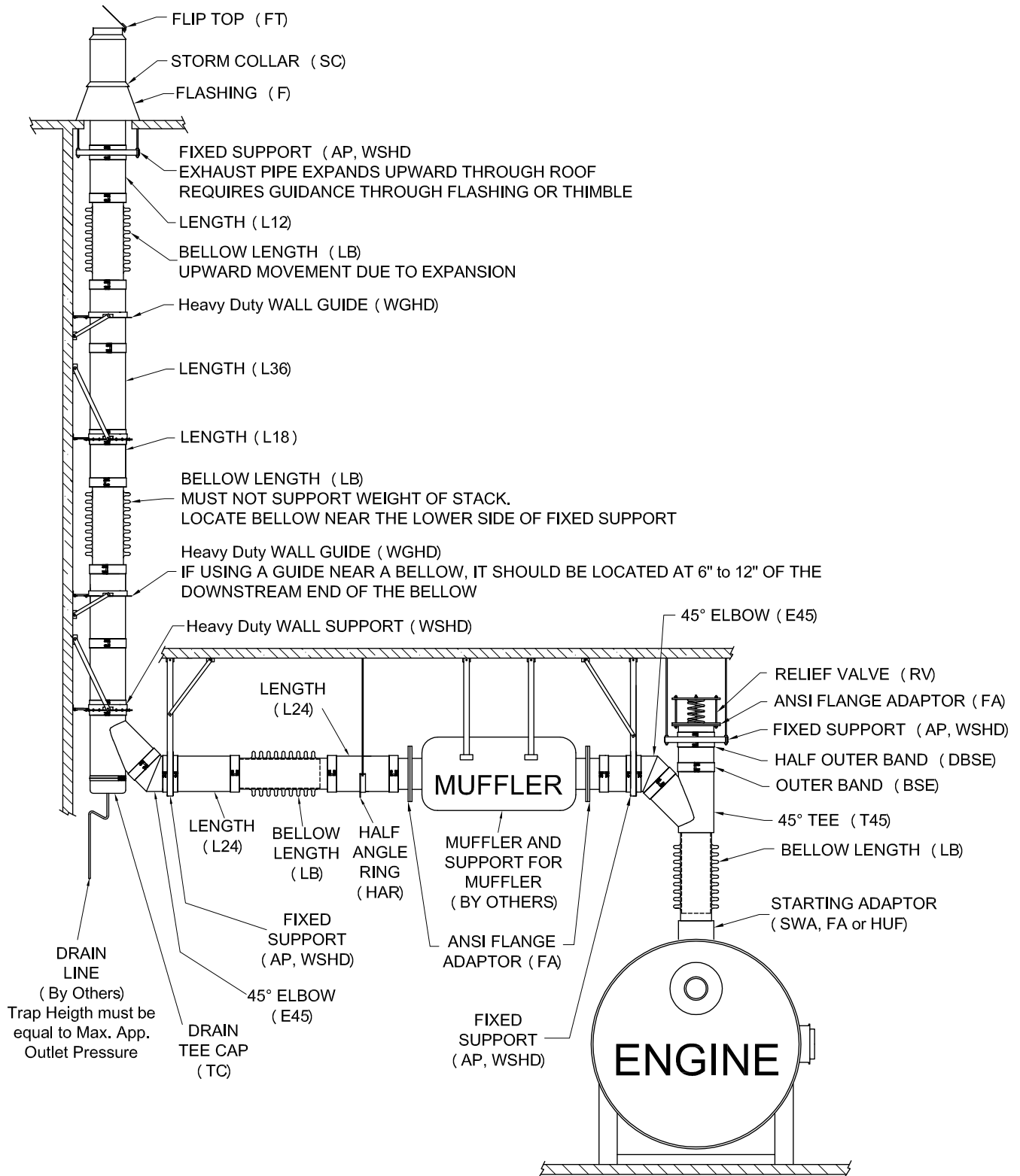

Figure 83 - Sample installation for Diesel Generator Exhaust

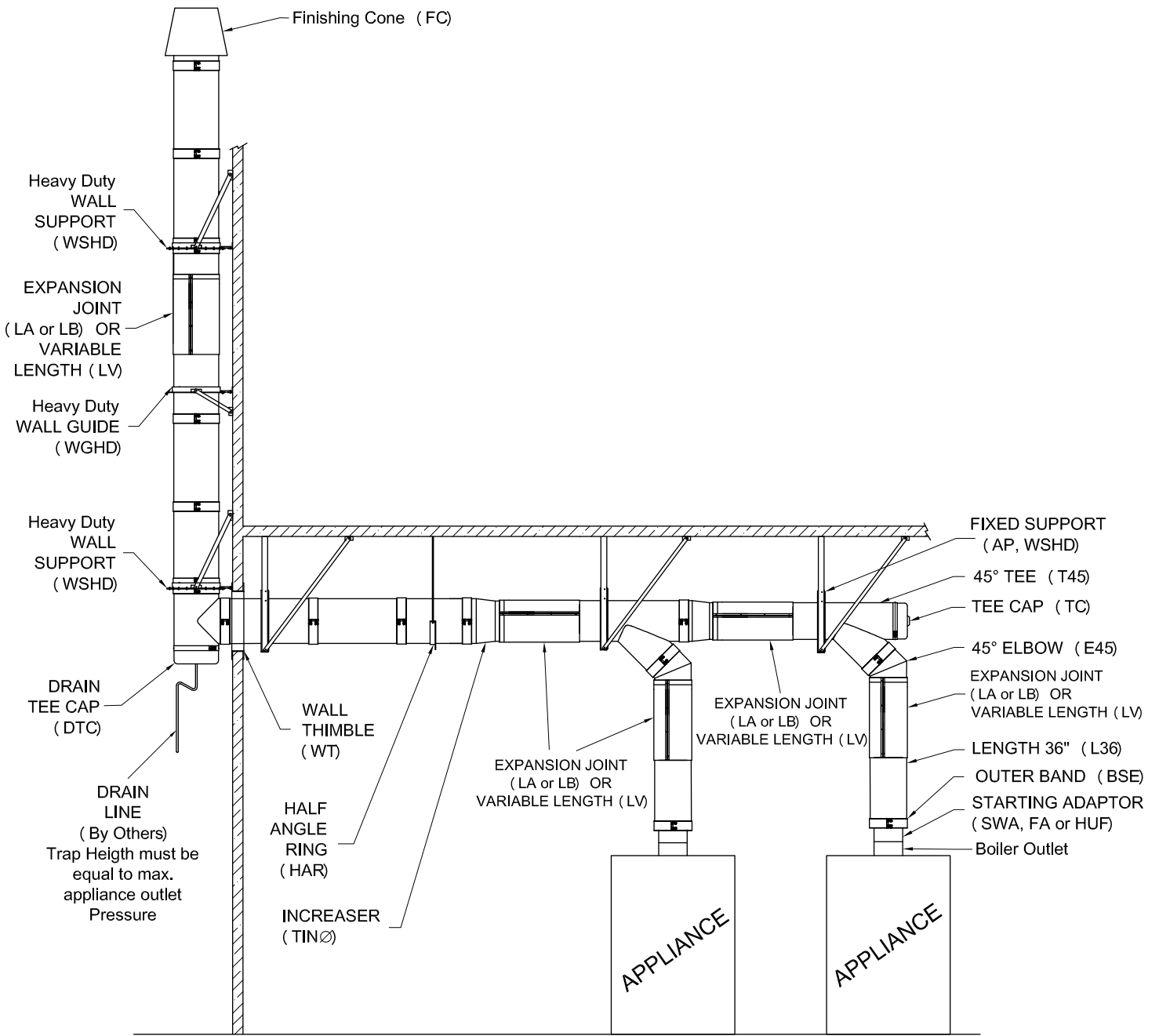

Figure 84 - Sample Installation for Boiler Applications

NOTE: DIAGRAMS & ILLUSTRATIONS ARE NOT TO SCALE.

SECTION P - CHIMNEY LINERS

The DCL is designed for use in a masonry or factory-built chimney to provide the flue gas venting of liquid and gas fire appliances.

DCL has been tested and Listed to UL 1777 (standard for chimney liners) for use with gas fired appliances with flue gases up to 1000°F and short term exposure up to 1700°F. It is also listed to Class 2 CAN/ULC S635 (standard for lining systems in existing masonry or factory-built chimneys and vents) for use with gas and liquid fired appliances with maximum continuous flue gas temperatures of 572°F (300°C).

INSTALLATION:

Prior to the installation of the liner, the masonry chimney should be thoroughly inspected for any damages such as cracks, void areas, missing bricks or mortar and other defects. Damaged areas should be repaired prior to installation. Care should also be taken to ensure that the masonry chimney is clean and free from any buildup of creosote. Consult a certified Chimney Sweep if necessary.

The air space clearances between the masonry chimney exterior and any combustible materials should be checked to make sure the chimney is in accordance with any clearance requirement specified in NFPA 211, any other recognized building codes or the manufacturer's installation instruction.

WARNING:

Do not fill the air space between the liner and the chimney with insulation or any other materials.

In an existing masonry chimney, the maximum internal dimensions necessary for installation will be the liner inside diameter plus approximately 2", to allow for the V-Bands that connect the individual lengths together.

If the liner is to be used inside an existing factory-built chimney or vent, such chimney -vent must be cleaned and inspected for any defects prior to installation. Such chimney should also incorporate all parts (support, shield, etc.) specified by the chimney-vent manufacturer and that clearances to combustible are in accordance with their installation instruction. Unless a specific sizing assessment have been conducted and confirms adequate for the venting of the appliance, no portion of the liner should be sized smaller than specified in the appliance manufacturer's instructions. Also, it is important to do a correct sizing for the venting of a low temperature flue products in geographical areas experiencing sustained low ambient temperature.

The Liner is not to be field ovalized.

The DCL liner should extend a minimum of 1 foot above the masonry chimney in which it is installed. Follow local code requirements for minimum spacing requirements from chimney terminations to surrounding structures.

The safe operation of a lining system is based on the use of parts supplied by Duravent and its performance may be affected if the combination of these parts is not used in actual building construction.

All wall penetration assemblies are not to be located directly behind a heating appliance.

Maximum height of the liner will depend on the system diameter and the method of supporting.

Refer to table 7 for support options and use the maximum height limitations specified for the DCL Model.

DCL can also be used as a connector between the appliance and the masonry chimney being lined. Follow local code requirements for minimum airspace clearance from combustibles to single wall connectors.

If the liner is also use as a connector between appliance and the masonry chimney, it must follow local codes requirement for minimum clearance as a single wall connectors.

A rain cap or any other termination option from Duravent DIS offering is recommended for use on the DCL . This will reduce water access to the inside of the flue. Listed rain caps with screen are necessary /required in some areas, but may be susceptible to blockage through freezing moisture in areas with freezing temperature. Consult the authority having jurisdiction for requirement in your area.

Inspection of the lining system should be done periodically (at least annually) by an authorized representative of Duravent or by any other qualified inspector such as a chimney sweep. Failure to inspect and clean the liner could lead to premature corrosion and result in potential operational problems.

The access for inspection and cleaning can be done through the top of the chimney by removal of the cap or from the base by removal of portion of the connector portion.

Cleaning using chimney brushes of the same size as the flue can be used.

POSTING OF NOTICE: Once installation is completed, a notice should be posted near the appliance outlet. This notice should mention that this system is for use with either gas or oil appliances only.

INSTALLATION GUIDELINES:

The DCL Model can be supported from the top using Guy Supports and stainless steel wire, or from the bottom using a Support Plate. See figures 85 and 86.

Determine the location point where the vent system will penetrate the masonry wall (the position of the appliance will impact this) and prepare an opening through the masonry and any existing liner, large enough to easily accommodate DCL and allow easy access for the Support Plate if necessary.

Determine the overall length of the system by measuring from the prepared opening to a point 2 feet above the top of the masonry chimney. Add the distance from the appliance outlet to the prepared opening accounting for any bends.

All DCL dimensions are actual lengths after assembly.

NOTE: Stainless steel wire rope (by others) is to be used to hand the vent system from the top of the masonry chimney or from the top of the existing chimney.

-The stainless steel wire rope is attached to the Guy Support Band and is secured with cable clamps (by others).

-The stainless steel wire rope is secured in a similar manner to the top platform of the masonry chimney or existing vent.

-Use the appropriate size stainless steel wire rope (1/8" min) to accommodate the required total loads of the vent system.

It may be necessary to fabricate a platform (at top of chimney vent).

Attached the outlet of a Tee or Elbow to the inlet and of a length of pipe. Clamp the Guy Support below the V-Band and start lowering it down the chimney flue. Add lengths of pipe as necessary.

DO NOT USE GALVANIZED WIRE ROPE

If a Support Plate is needed at the bottom of the liner, make sure it comes to rest on the existing bracing which should already be installed (by others).

Complete the system at the top with the use of a Flashing, Storm Collar, and Cap. Sealant should be used to seal the Collar and perimeter of the Flashing.



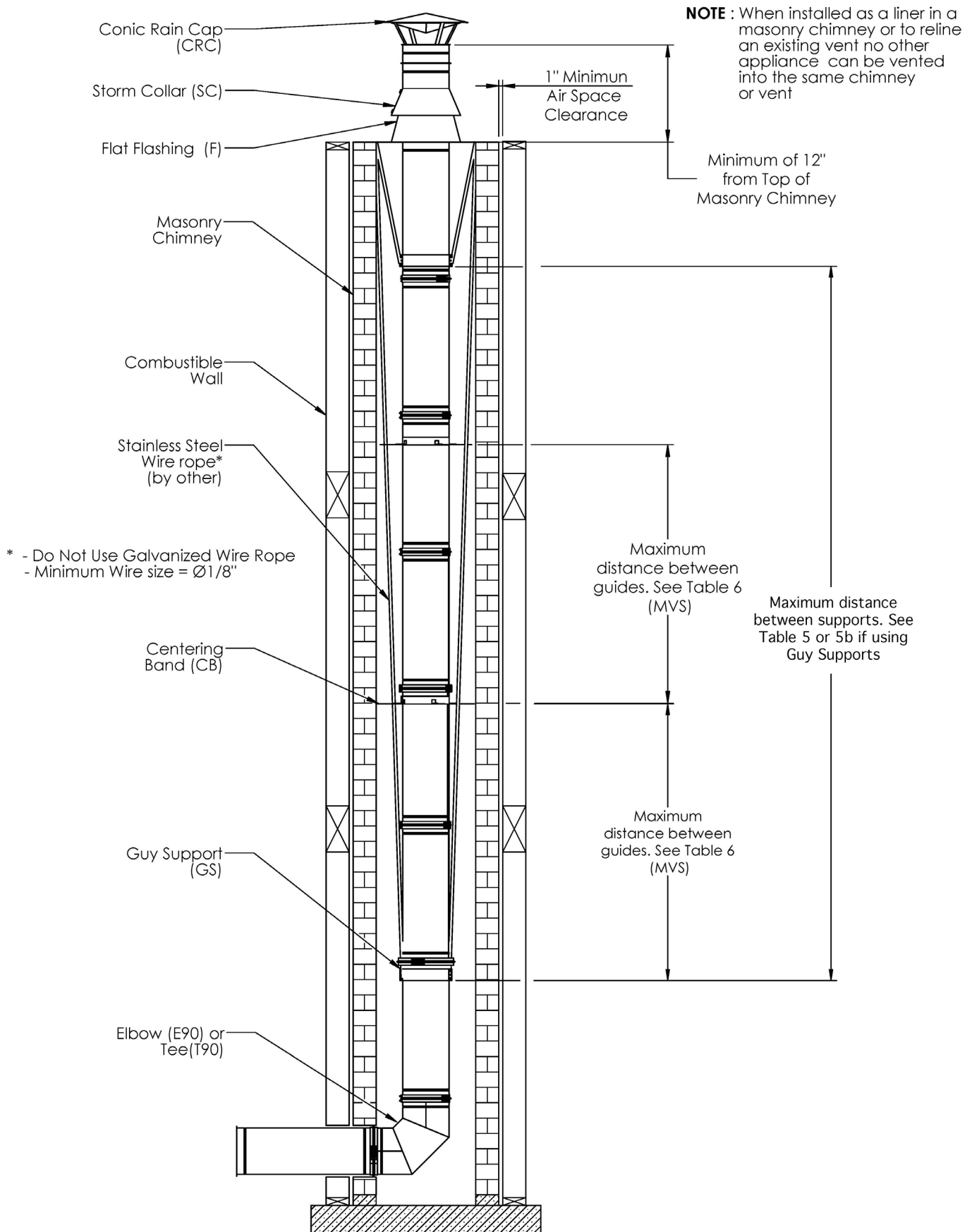

Figure 85

NOTE: DIAGRAMS & ILLUSTRATIONS ARE NOT TO SCALE.

NOTE : When installed as a liner in a masonry chimney or to reline an existing vent no other appliance can be vented into the same chimney or vent

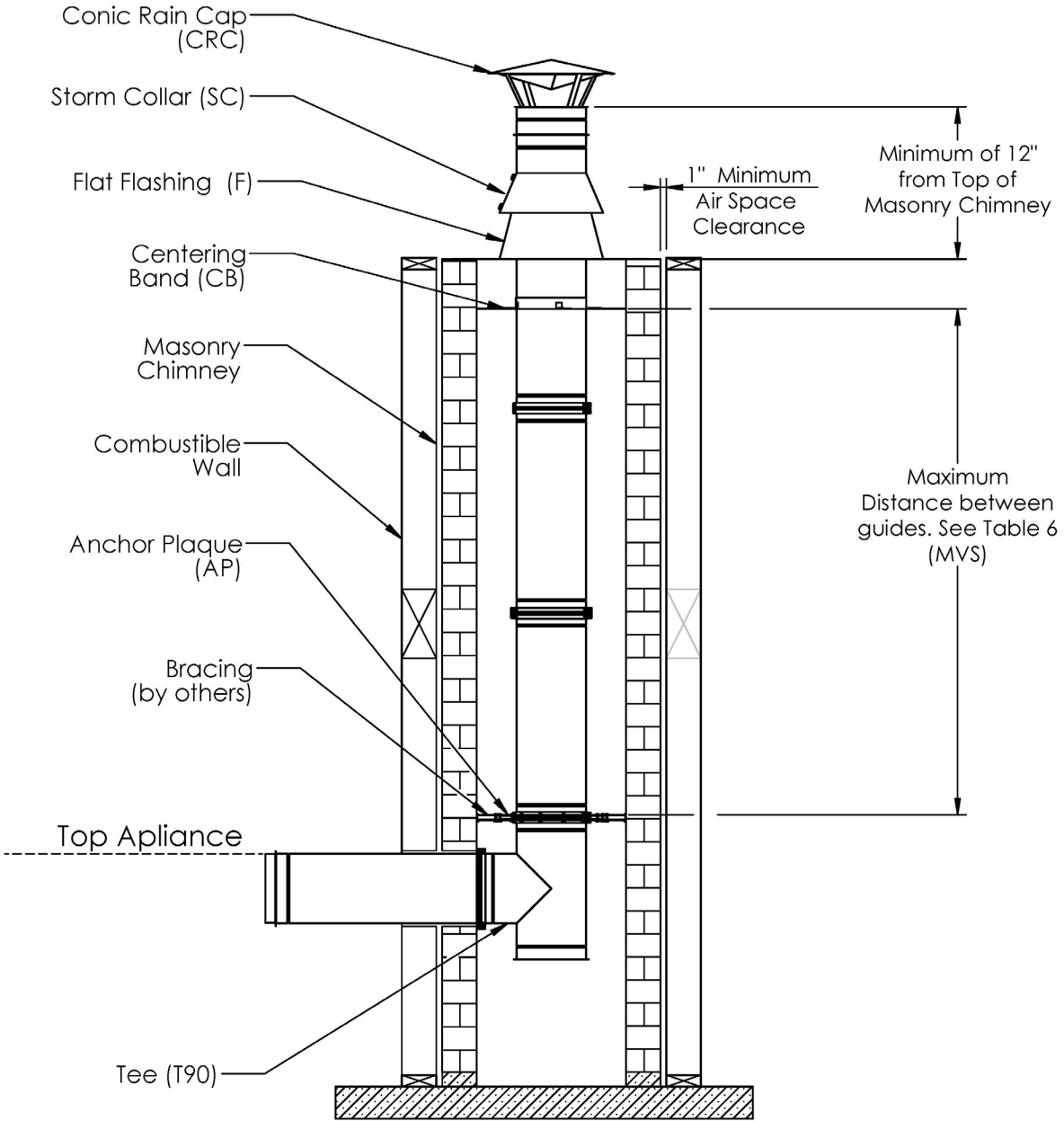

Figure 86

NOTE: DIAGRAMS & ILLUSTRATIONS ARE NOT TO SCALE.

WARRANTY

These products have a limited warranty. Please read the warranty to be familiar with its coverage.

Retain this manual. File it with your other documents for future reference.

PRODUCT REFERENCE INFORMATION

Please contact Duravent for the phone number of your nearest Duravent dealer who will answer your questions or address your concerns.

Normally, all parts should be ordered through your Duravent distributor or dealer. Parts will be shipped at prevailing prices at time of order.

When ordering repair parts, always give the following information:

1. The model number of the chimney system.
2. The part number.
3. The description of the part.
4. The quantity required.
5. The installation date of the chimney system.

If you encounter any problems or have any questions concerning the installation or application of this system, please contact our dealer.

duraventTM

2125 MONTEREY ST. • LAVAL, QC., CANADA • H7L 3T6
800-835-4429; www.Duravent.com

Duravent reserves the right to make changes at any time, without notice, in design, materials, specifications, prices.
Consult your local distributor for chimney system code information.

Printed in Canada © 2025 DuraVent
PI-GD-3Z-PRO-DV L483 REV.8.1 03/27/2025

NOTE: DIAGRAMS & ILLUSTRATIONS ARE NOT TO SCALE.