

# Installation Instructions



FasNSeal Fixed Blade Damper

**A MAJOR CAUSE OF VENT RELATED FIRES IS FAILURE TO MAINTAIN REQUIRED CLEARANCES (AIR SPACES) TO COMBUSTIBLE MATERIALS. IT IS OF THE UTMOST IMPORTANCE THAT FASNSEAL BE INSTALLED ONLY IN ACCORDANCE WITH THESE INSTRUCTIONS.**

**FASNSEAL® SUPPLEMENTAL  
INSTRUCTION- FIXED DAMPER**

**DuraVent®**



## INTRODUCTION

The purpose of the Fixed Blade Damper is to ensure optimum pressures through an appliance. The Damper will aid in the proper operation and efficiency of the appliance by preventing higher than desired draft readings.

## INSTALLATION

• **IMPORTANT: The max rated temperature for the fixed blade damper is 392°F (200°C). When the damper is installed, the entire FNS system is to be de-rated in maximum temperature to this value.**

- Always follow appliance manufacturer's installation instructions for proper appliance setup and venting requirements.
- Refer to the FasNSeal SW & W2 Installation Instructions for correct installation to FasNSeal vent lengths and adapters.
- It is important to note that the Damper can be installed vertically, diagonally and horizontally.
- If the Damper is going to be installed horizontally, make sure the Damper Axis is horizontal (**Fig.1**). Make sure the venting is pitched towards the boiler by a value of  $\frac{1}{4}$ " drop for every foot of vent length (**Fig.2** and

**Fig.3**) for proper condensate management. The weight on the damper is a fail safe to make certain that the damper will be open in the event of failure. Ensure that the weight is at the top of the damper plate when closed in the Horizontal (**Fig.1**).

Horizontal Installation (**Fig.1, Fig.2, Fig.3**)

- To prevent the build up of condensation in horizontal installations, it is required to use an Eccentric Increaser rather than Tapered Increasers at the male connection of the damper (**Fig.2**).
- Installation of the Damper in the flue venting of an appliance should be at the breach of the appliance or as close as possible.
- Lock the Damper position to the 90 degree value so that it is in the full open position.
- Ensure the female end is pointing away from the appliance.
- Once the damper has been correctly installed in the venting flue, lock the damper to 90° and then operate the burner until the appliance is sufficiently warmed up and chamber pressure has stabilized.
- After the chamber pressure is lower than what is prescribed by the OEM, proceed

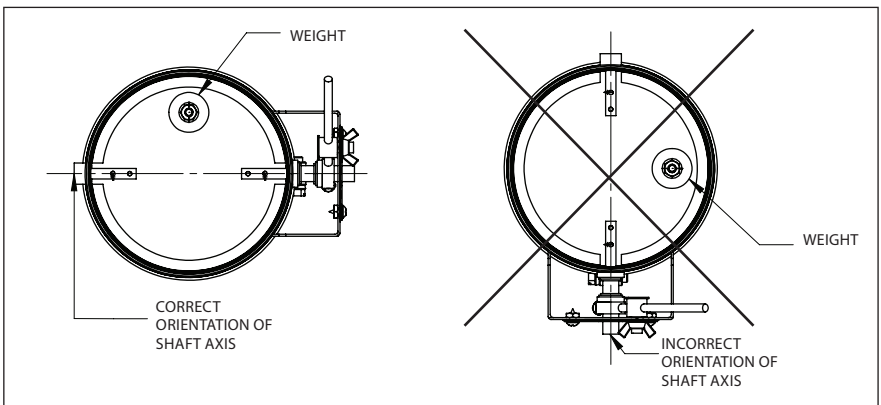

**Figure 1**

with closing off the damper until the desired chamber pressure has been achieved.

- At this point lock the damper blade in position and begin the burner set up as prescribed by the OEM.

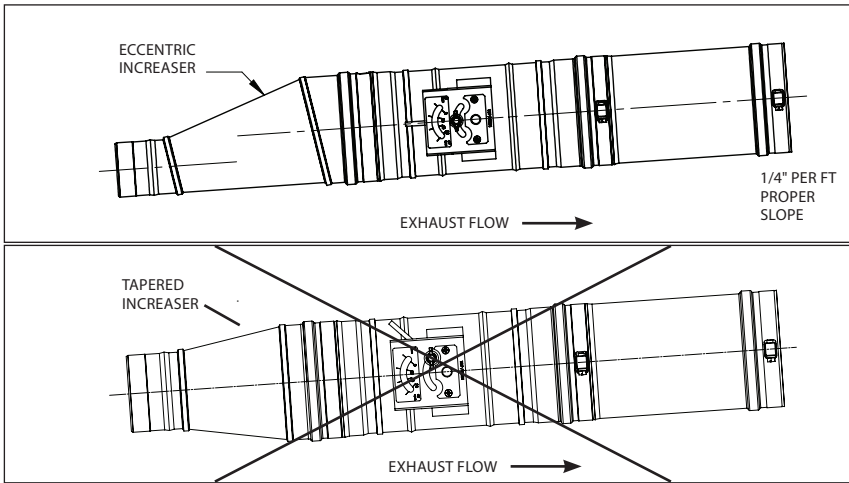

**Figure 2**

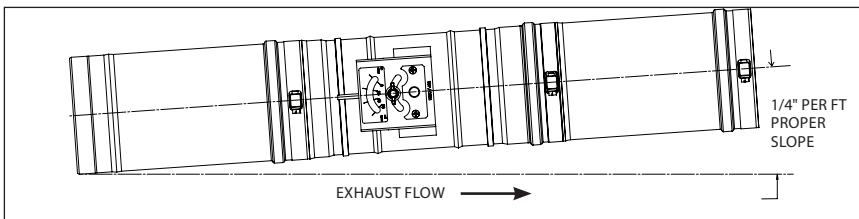

**Figure 3**

## DURAVENT LIMITED LIFETIME WARRANTY

M&G DuraVent, Inc. ("DuraVent") provides this limited lifetime warranty for all of its products with the exception of Ventinox® (lifetime), and PolyPro® (ten years). Subject to the limitations set forth below, DuraVent warrants that its products will be free from defects in material or manufacturing, if properly installed, maintained and used. DuraVent products are fully warranted if installed only by a professional installer. This Warranty is transferable from the original homeowner to the buyer of the home. This warranty does not cover normal wear and tear, smoke damage or damage caused by chimney fires, acts of God, or any product that was: (1) purchased other than from an authorized DuraVent dealer, retailer or distributor; (2) modified or altered; (3) improperly serviced, inspected or cleaned; or (4) subject to negligence or any use not in accordance with the installation instructions included with the product as determined by DuraVent. Installation instructions are available online at [www.duravent.com](http://www.duravent.com) under Support/Literature and through our Customer Service Department 800-835-4429 or [customerservice@duravent.com](mailto:customerservice@duravent.com). This limited lifetime warranty applies only to parts manufactured by DuraVent.

DuraVent provides the following warranties for its products: One Hundred Percent (100%) MSRP 15 years from the date of purchase, and Fifty Percent (50%) thereafter, except for the following limitations on: all Termination Caps and DuraBlack® are warranted at One Hundred Percent (100%) for five years.

All warranty obligations of DuraVent shall be limited to repair or replacement of the defective product pursuant to the terms and conditions applicable to each product line. These remedies shall constitute DuraVent's sole obligation and sole remedy under this warranty. This warranty provides no cash surrender value. The terms and conditions of this warranty may not be modified, altered or waived by any action, inaction or representation, whether oral or in writing, except upon the express, written authority of an executive officer of DuraVent.

Corn, bio-fuels, driftwood or other wood containing salt, preservative-treated lumber, plastic and household trash or garbage, or wood pellets containing such materials must not be burned in the appliance or fireplace. In case of a chimney fire, the chimney must be inspected and approved by a certified Chimney Sweep before reuse. After each annual inspection, maintenance, and cleaning, the certified Chimney Sweep must fill out and date the appropriate section of the warranty card provided with the chimney liner.

**LIMITATIONS ON INTERNET SALES:** Notwithstanding any other terms or conditions of this Limited Lifetime Warranty, DuraVent provides no warranty for the following specific products if such products are not installed by a qualified professional installer: DuraTech®, DuraPlus® HTC, DuraTech® Premium, DuraChimney® II, PelletVent® Pro, DirectVent® Pro, FasNSeal®, FasNSeal® W2, FasNSeal® Flex, and PolyPro®, and DuraVent's relining products including DuraLiner®, DuraFlex® (SW, Pro, 316, 304), and Ventinox®. For purposes of this warranty, a trained professional installer is defined as one of the following: licensed contractors with prior chimney installation experience, CSIA Certified Chimney Sweeps, NFI Certified Specialists, or WETT Certified Professionals.

DuraVent must be notified and given the opportunity to inspect defective product prior to replacement under the terms of this limited lifetime warranty. All warranty claims must be submitted with proof of purchase. Labor and installation costs are not covered under this warranty. To obtain warranty service contact: DuraVent Warranty Service, 877 Cotting Ct., Vacaville CA 95688, or call 800-835-4429.

WHERE LAWFUL, DURAVENT DISCLAIMS ALL OTHER WARRANTIES, INCLUDING BUT NOT LIMITED TO IMPLIED WARRANTIES OF MERCHANTABILITY AND FITNESS FOR A PARTICULAR PURPOSE. IN NO EVENT WILL DURAVENT BE LIABLE FOR INCIDENTAL, CONSEQUENTIAL, PUNITIVE OR SPECIAL DAMAGES OR DIRECT OR INDIRECT LOSS OF ANY KIND, INCLUDING BUT NOT LIMITED TO PROPERTY DAMAGE AND PERSONAL INJURY. DURAVENT'S ENTIRE LIABILITY IS LIMITED TO THE PURCHASE PRICE OF THIS PRODUCT. SOME STATES DO NOT ALLOW LIMITATIONS ON IMPLIED WARRANTIES, OR THE EXCLUSION OR LIMITATION OF INCIDENTAL OR CONSEQUENTIAL DAMAGES, SO THE ABOVE LIMITATIONS AND EXCLUSIONS MAY NOT APPLY TO YOU. THIS LIMITED WARRANTY GIVES YOU SPECIFIC LEGAL RIGHTS, AND YOU MAY ALSO HAVE OTHER RIGHTS THAT VARY FROM STATE TO STATE.

For the most up-to-date installation instructions, see [www.duravent.com](http://www.duravent.com)

Manufactured in Canada

# DuraVent®

**Customer Service Support: 800-835-4429 • 707-446-4740 FAX [www.duravent.com](http://www.duravent.com)**

FasNSeal is a registered trademark of DuraVent, Inc.  
All rights reserved. Made in Canada. ©2012, 2017

L1150SUP\_820013661\_Install Instructions\_FasNSeal\_05-08-18\_V3